

REV.	ECN NO OR DESCRIPTION	REVISED	DATE
A	PDR NO:T170830-2A/B	Steven	2018.03.28

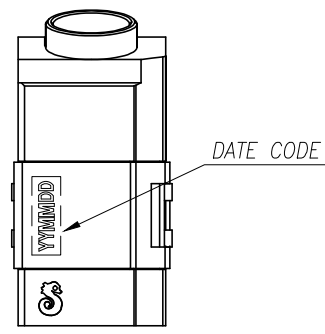
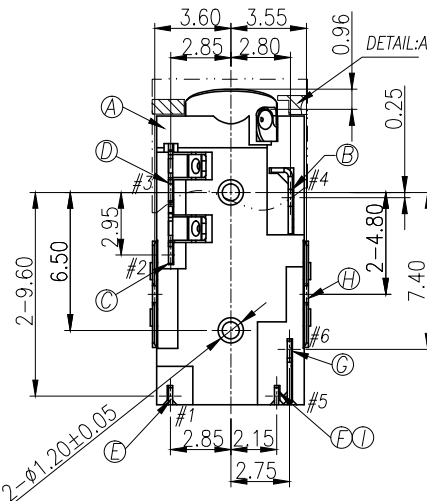
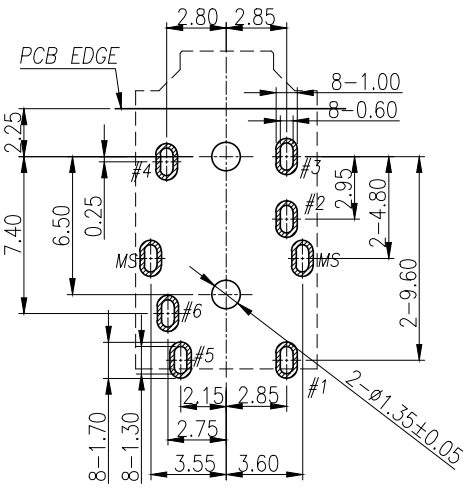
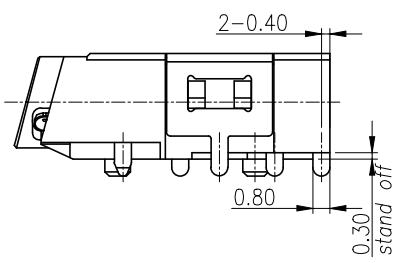
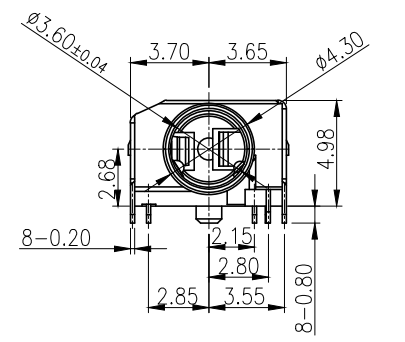
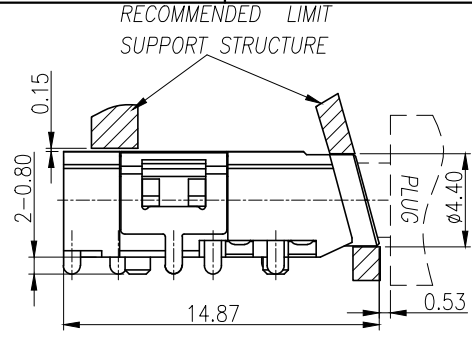

- SPECIFICATIONS:
- ELECTRICAL CHARACTERISTICS:
    - 1-1. RATING: 12V 1A
    - 1-2. CONTACT RESISTANCE: 50mΩ MAX.(INITIAL)
    - 1-3. DIELECTRIC WITHSTANDING VOLTAGE: 500V AC FOR ONE MINUTE.
    - 1-4. INSULATION RESISTANCE: 100MΩ MIN. MEASURED BY 500 VDC.
  - LIFE TEST: 2,000 CYCLES MIN.
  - MECHANICAL CHARACTERISTICS:
    - 3-1. BEFORE LIFE TEST: INSERTION FORCE: 0.8-3.0 Kgf, EXTRACTION FORCE: 0.6-1.8 Kgf,
    - 3-2. AFTER LIFE TEST: INSERTION FORCE: 2.5 Kgf MAX, EXTRACTION FORCE: 0.5 Kgf MIN,
    - 3-3. AFTER LIFE TEST, CONTACT RESISTANCE: 100mΩ MAX.
  - PACKAGING : TAPE & REEL.
  - AFTER HUMIDITY TEST, INSULATION RESISTANCE: 50MΩ MIN.
  - TO CONFORM TO SINGATRON HAZARDOUS SUBSTANCE FREE SPEC.
  - HALOGEN FREE PRODUCT IDENTIFICATION MARK ON PRODUCT:
  - HALOGEN FREE PRODUCT IDENTIFICATION LOGO ON PACKAGING:
  - FOR REFLOW SOLDERING LEAD-FREE PROCESS.
  - PRINTED DATE CODE "YYMMDD-" ON TOP OF CONNECTOR.

2SJ3072-254X11F

1:GOLD FLASH  
2: Au 30u"

RECOMMENDED PCB LAYOUT  
TOP VIEW ; TOL.±0.05

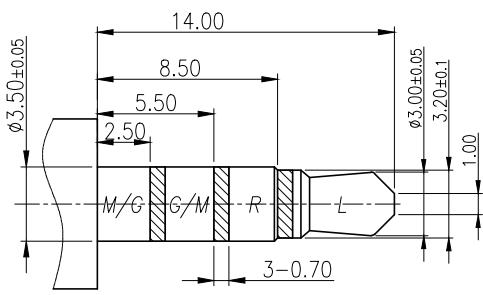

RECOMMENDED PLUG;TOL.±0.05  
03.5 4-POLE STANDARD PLUG

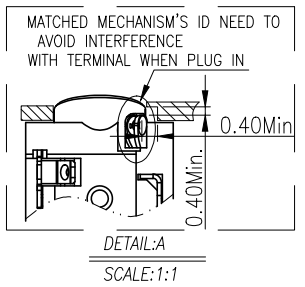
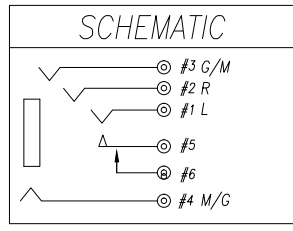

I	SEPARATOR	1	HIGH TEMP.THERMOPLASTIC UL 94V-0	BLACK
H	SHELL	1	SUS304-1/2H 0.2t	Ni 60u" MIN
G	MAKE TERMINAL	1	PHOSPHOR BRONZE 0.2t	GOLD FLASH ON CONTACT AREA;
F	TRANSFER TERMINAL	1	PHOSPHOR BRONZE 0.2t	GOLD FLASH ON SOLDER AREA;
E	TIP SPRING	1	SUS304-1/2H 0.2t	ALL OVER NICKEL 50u" MIN. PLATING.
D	RING-B	1	PHOSPHOR BRONZE 0.2t	G/F OR Au 30u"ON CONTACT AREA;
C	RING-A	1	PHOSPHOR BRONZE 0.2t	GOLD FLASH ON SOLDER AREA;
B	EARTH	1	PHOSPHOR BRONZE 0.2t	ALL OVER NICKEL 50u" MIN. PLATING.
A	BODY	1	HIGH TEMP.THERMOPLASTIC UL 94V-0	BLACK
NO	DESCRIPTION	QTY	MATERIAL	PLATING & COLOR

UNLESS OTHERWISE SPECIFIED TOLERANCES		Singatron Enterprise Co., Ltd. 信音企業股份有限公司	
DECIMALS:	ANGLES:	TITLE 3.50 PHONE JACK	
X :±0.5	X :±2°	DWN	Steven PART NO.2SJ3072-254X11F
X.X :±0.3	X.X :±1°	CHKD	Bruce SCALE 1:1 UNIT: mm
X.XX :±0.2		APVD	Liao SIZE: A3 SHEET:1 OF 1 REV: A
CUSTOMER COPY			