

REV	ECN NO	OR DESCRIPTION	REVISED	DATE
A	PDR NO: T160804-3A		Peng	2017.03.15

SPECIFICATIONS:

ELECTRICAL CHARACTERISTICS:

- 1-1. RATING: 12V 1A
- 1-2. CONTACT RESISTANCE: 50mΩ MAX (INITIAL)
- 1-3. DIELECTRIC WITHSTANDING VOLTAGE: 500V AC FOR ONE MINUTE.
- 1-4. INSULATION RESISTANCE: 100MΩ MIN. MEASURED BY 500V DC

MECHANICAL CHARACTERISTICS:

- 2-1. INSERTION FORCE : 0.3~3.0 KGF
- 2-2. WITHDRAWAL FORCE : 0.3~3.0 KGF
3. LIFE TEST: 5,000 CYCLES MIN.
4. OTHER GENERAL SPEC. TO REFER "SJ3072-302111F SPEC."
5. TO CONFORM TO SINGATRON HAZARDOUS SUBSTANCE FREE SPEC.
6. HALOGEN FREE PRODUCT IDENTIFICATION MARK ON PRODUCT:
7. HALOGEN FREE PRODUCT IDENTIFICATION LOGO ON PACKAGING:
8. FOR REFLOW SOLDERING LEAD-FREE PROCESS.
9. PLEASE PUT THE PRODUCT IN A CONDITION WHERE IS FULL OF NITROGEN WHEN PASS THE IR REFLOW.

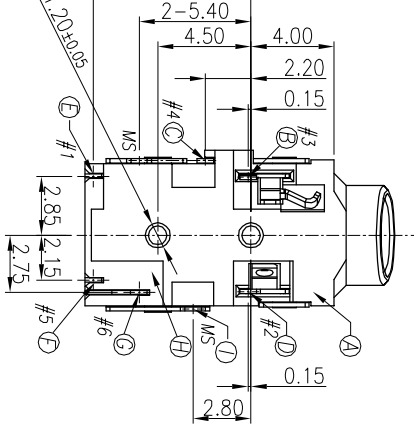
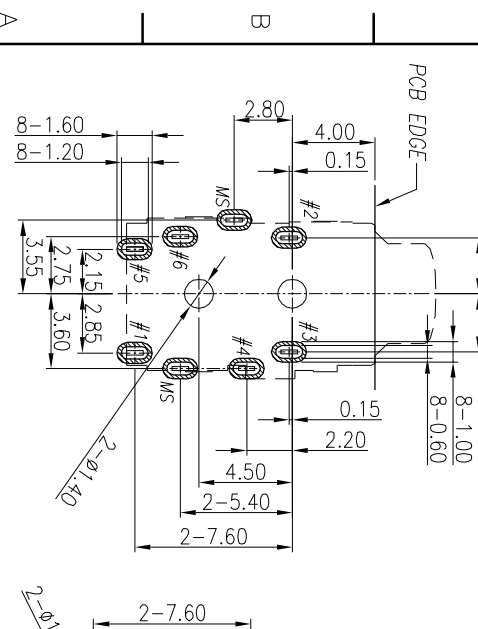
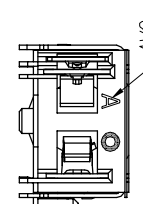
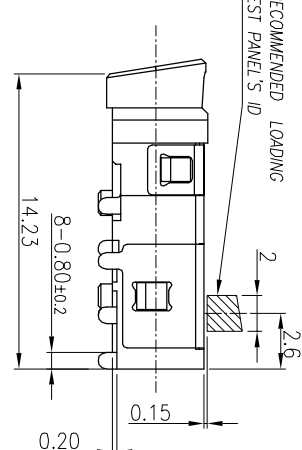
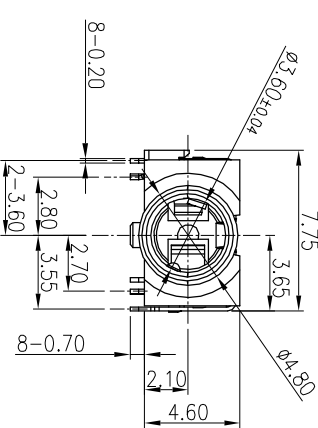
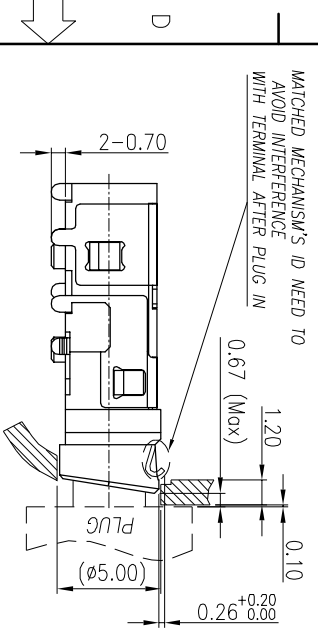

RECOMMENDED PCB LAYOUT
TOP VIEW : TOL.±0.05

NO	DESCRIPTION	QTY	MATERIAL	PLATING & COLOR
J	MYLAR	1	KAPTON 0.1T	YELLOW
I	SHIELD	1	PHOSPHOR BRONZE 0.2t	Ni 60μm Min
H	SEPARATOR	1	HIGH TEMP.THERMOPLASTIC UL 94V-0	BLACK
G	MAKE TERMINAL	1	PHOSPHOR BRONZE 0.2t	
F	TRANSFER TERMINAL	1	PHOSPHOR BRONZE 0.2t	
E	TIP SPRING	1	PHOSPHOR BRONZE 0.2t	
D	RING-A	1	PHOSPHOR BRONZE 0.2t	
C	EARTH	1	PHOSPHOR BRONZE 0.2t	
B	RING-B	1	PHOSPHOR BRONZE 0.2t	
A	BODY	1	PA4T-30% GF (TX1) UL 94V-0	Pantone cool gray 11C

UNLESS OTHERWISE SPECIFIED TOLERANCES

DECIMALS: ANGLES:

X : ±0.5 X : ±2°
X.X : ±0.3 X.X : ±1°
X.XX : ±0.2

CUSTOMER COPY

Singatron Enterprise Co., Ltd.
信晉企業股份有限公司

TITLE: 3.5φ PHONE JACK
DWG: Peng PART NO. 2S3072-302111F
CHKD: Bruce SCALE 1:1 UNIT: mm
APVD: Lussen SIZE: A3 SHEET: 1 OF 1 REV: A