

REV	ECN NO	OR DESCRIPTION	REVISED	DATE
A	PDR NO: T131213-7A		Kevin	2014.05.13

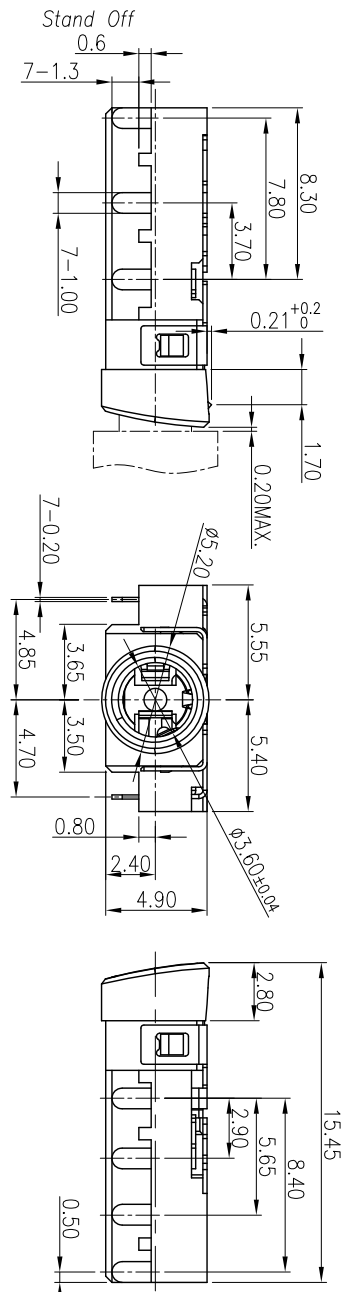

- SPECIFICATIONS:
- ELECTRICAL CHARACTERISTICS:
    - RATING: 12V 1A
    - CONTACT RESISTANCE: 50mΩ MAX.(INITIAL)
    - DIELECTRIC WITHSTANDING VOLTAGE: 500V AC FOR ONE MINUTE.
    - INSULATION RESISTANCE: 100MΩ MIN. MEASURED BY 500V DC
  - MECHANICAL CHARACTERISTICS:
    - INSERTION FORCE : 0.3~3.0 KGF
    - WITHDRAWAL FORCE : 0.3~3.0 KGF
  - LIFE TEST: 5,000 CYCLES MIN.
  - OTHER GENERAL SPEC. TO REFER "2SJ3080 SERIES SPEC".
  - TO CONFORM TO SINGATRON HAZARDOUS SUBSTANCE FREE SPEC.
  - HALOGEN FREE PRODUCT IDENTIFICATION MARK ON PRODUCT:
  - HALOGEN FREE PRODUCT IDENTIFICATION LOGO ON PACKAGING:
  - FOR REFLOW SOLDERING LEAD-FREE PROCESS.

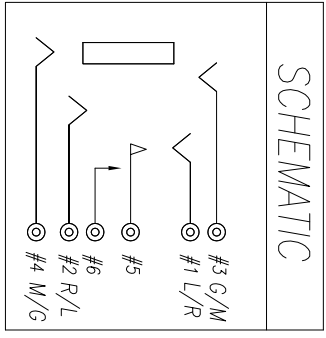
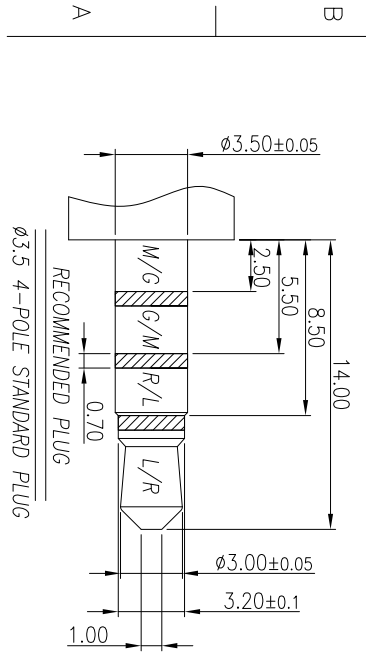
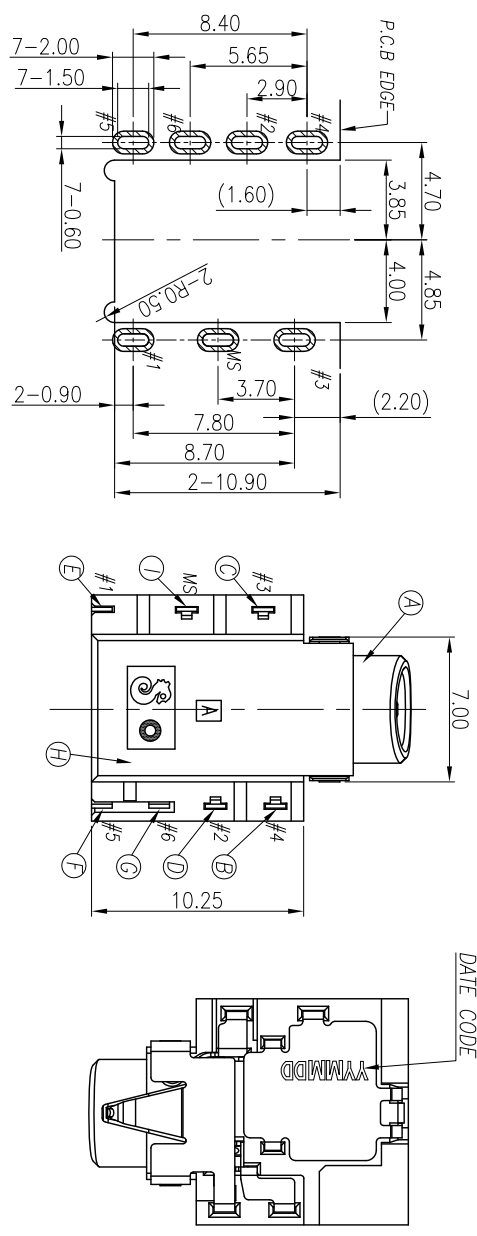

I	SHELL	1	BRASS 0.2t	Ni 60U Min.
H	SEPARATOR	1	HIGH TEMP.THERMOPLASTIC UL 94V-0	BLACK
G	MAKE TERMINAL	1	PHOSPHOR BRONZE 0.2t	GOLD FLASH ON CONTACT AREA GOLD FLASH ON SOLDER AREA ALL OVER 50U" Ni
F	TRANSFER TERMINAL	1	PHOSPHOR BRONZE 0.2t	
E	TIP SPRING	1	PHOSPHOR BRONZE 0.2t	GOLD FLASH ON CONTACT AREA
D	RING A	1	PHOSPHOR BRONZE 0.2t	Matte Sn60U" ON SOLDER AREA ALL OVER 50U" Ni
C	RING B	1	PHOSPHOR BRONZE 0.2t	
B	EARTH	1	PHOSPHOR BRONZE 0.2t	
A	BODY	1	HIGH TEMP.THERMOPLASTIC UL 94V-0	BLACK
NO	DESCRIPTION	QTY	MATERIAL	PLATING & COLOR
UNLESS OTHERWISE SPECIFIED TOLERANCES				
DECIMALS: ANGLES:				
X	:±0.5	X	:±2°	
X.X	:±0.3	X.X	:±1°	
X.XX	:±0.2			
TITLE		3.5φ PHONE JACK		
DWN	Kevin	PART NO.	2SJ3080-063111F	
CHKD	Bruce	SCALE	4:1 UNIT: mm	
APVD	Lussen	SIZE: A3	SHEET: 1 OF 1 REV: A	
Singatron Enterprise Co., Ltd. 信譽企業股份有限公司				
CUSTOMER COPY				