

REV.	ECN NO OR DESCRIPTION	REVISED	DATE
A	PDR NO: T200619-3A&3B	Xinzhi	2020.12.18

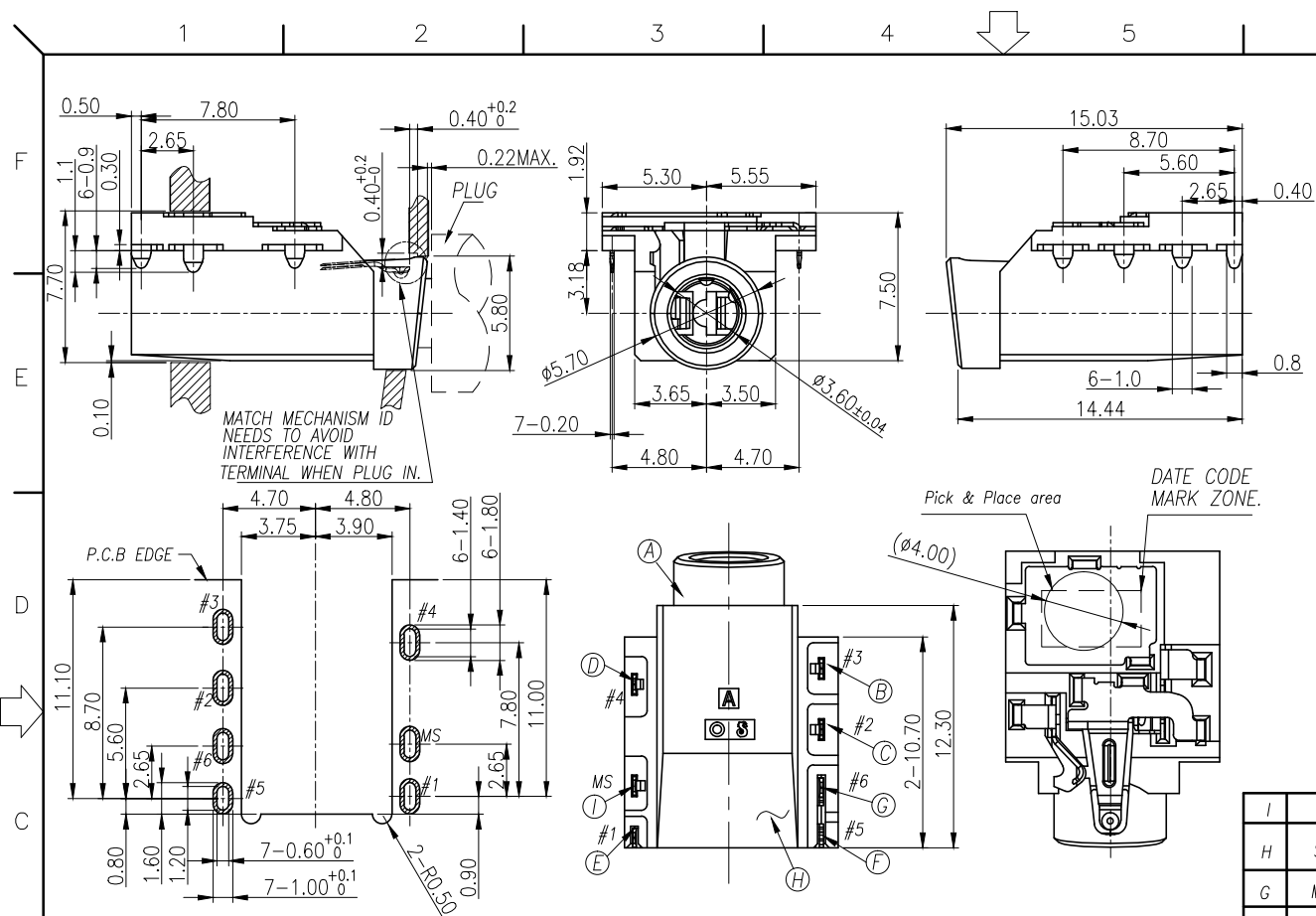

SPECIFICATIONS:

- ELECTRICAL CHARACTERISTICS:
 - 1-1. RATING: 12V 1A
 - 1-2. CONTACT RESISTANCE: 50mΩ MAX.(INITIAL)
 - 1-3. DIELECTRIC WITHSTANDING VOLTAGE: 500V AC FOR ONE MINUTE.
 - 1-4. INSULATION RESISTANCE: 100MΩ MIN. MEASURED BY 500 VDC.
- MECHANICAL CHARACTERISTICS:
 - 2-1. INSERTION FORCE: 1.0 - 2.5Kgf AFTER THE FIFTH TIME; 2.5 Kgf Max. After THE 2000th
 - 2-2. WITHDRAWAL FORCE: 0.6~1.8Kgf AFTER THE FIFTH TIME; 0.5 Kgf Min. After THE 2000th
- LIFE TEST: 2,000 CYCLES MIN.
- AFTER LIFE TEST, CONTACT RESISTANCE: 50mΩ MAX.
- PACKAGING : TAPE & REEL.
- TO CONFORM TO SINGATRON HAZARDOUS SUBSTANCE FREE SPEC.
- HALOGEN FREE PRODUCT IDENTIFICATION MARK ON PRODUCT:
- HALOGEN FREE PRODUCT IDENTIFICATION LOGO ON PACKAGING:
- FOR REFLOW SOLDERING LEAD-FREE PROCESS.
- PRINTED DATE CODE "YMD=" ON TOP OF CONNECTOR.

RECOMMENDED PCB LAYOUT
TOP VIEW ; TOL.±0.05

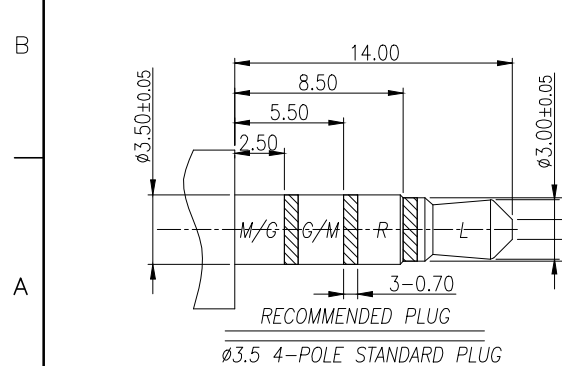
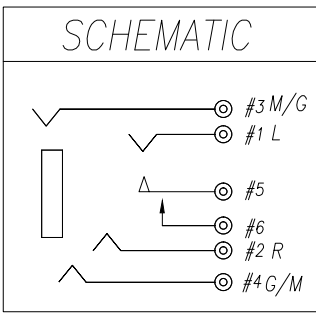

TABLE 1 :

P/N	PLATING SPEC
2SJ3080-153111F	GOLD FLASH ON CONTACT AREA;
2SJ3080-153211F	Au 30u" Min. ON CONTACT AREA



I	SHELL	1	STAINLESS STEEL, 0.2t	Ni 60u"Min.
H	SEPARATOR	1	HIGH TEMP.THERMOPLASTIC UL 94V-0	BLACK
G	MAKE TERMINAL	1	PHOSPHOR BRONZE 0.2t	GOLD GLASH ON CONTACT AREA; GOLD FLASH ON SOLDER AREA; ALL OVER 50u" Ni.
F	TRANSFER TERMINAL	1	PHOSPHOR BRONZE 0.2t	
E	TIP SPRING	1	STAINLESS STEEL, 0.2t	SEE TABLE QN CONTACT AREA; Matte Sn80u" QN SOLDER AREA ALL OVER 50u" Ni.
D	RING B	1	PHOSPHOR BRONZE 0.2t	
C	RING A	1	PHOSPHOR BRONZE 0.2t	SEE TABLE ON CONTACT AREA; GOLD FLASH ON SOLDER AREA; ALL OVER 50u" Ni.
B	EARTH	1	PHOSPHOR BRONZE 0.2t	SEE TABLE ON CONTACT AREA; Matte Sn80u" QN SOLDER AREA ALL OVER 50u" Ni.
A	BODY	1	HIGH TEMP.THERMOPLASTIC UL 94V-0	BLACK
NO	DESCRIPTION	QTY	MATERIAL	PLATING & COLOR

UNLESS OTHERWISE SPECIFIED TOLERANCES		Singatron Enterprise Co., Ltd. 信音企業股份有限公司	
DECIMALS: X :±0.5 X.X :±0.3 X.XX :±0.2		TITLE: 3.5Ø AUDIO JACK DWN: Xinzhi PART NO. 2SJ3080-153X11F CHKD: Bruce SCALE 4:1 UNIT: mm APVD: Liao SIZE: A3 SHEET:1 OF 1 REV:A	
CUSTOMER COPY			