

REV	ECN NO OR DESCRIPTION	REVISED	DATE
A	PDR NO.: T210816-11A	Guorong	2021.11.09

SPECIFICATIONS:

- ELECTRICAL CHARACTERISTICS:
 - RATING: 12V 1A
 - CONTACT RESISTANCE: 50mΩ Max (INITIAL)
 - DIELECTRIC WITHSTANDING VOLTAGE: 500V AC FOR ONE MINUTE.
 - INSULATION RESISTANCE: 100MΩ Min. MEASURED BY 500 VDC.
- MECHANICAL CHARACTERISTICS:
 - BEFORE LIFE TEST: INSERTION FORCE: 0.8-3.0 Kgf, EXTRACTION FORCE: 0.6-1.8 Kgf,
 - AFTER LIFE TEST: INSERTION FORCE: 2.5 Kgf Max, EXTRACTION FORCE: 0.5 Kgf Min.
- LIFE TEST: 2,000 CYCLES Min.
- AFTER LIFE TEST, CONTACT RESISTANCE: 100mΩ Max.
- PACKAGING: TAPE & REEL.
- AFTER HUMIDITY TEST, INSULATION RESISTANCE: 50MΩ Min.
- TO CONFORM TO SINGATRON HAZARDOUS SUBSTANCE FREE SPEC.
- HALOGEN FREE PRODUCT IDENTIFICATION MARK ON PRODUCT.
- HALOGEN FREE PRODUCT IDENTIFICATION LOGO ON PACKAGING.
- FOR REFLOW SOLDERING LEAD-FREE PROCESS.
- PRINTED DATE CODE "MMDD" ON TOP OF CONNECTOR.

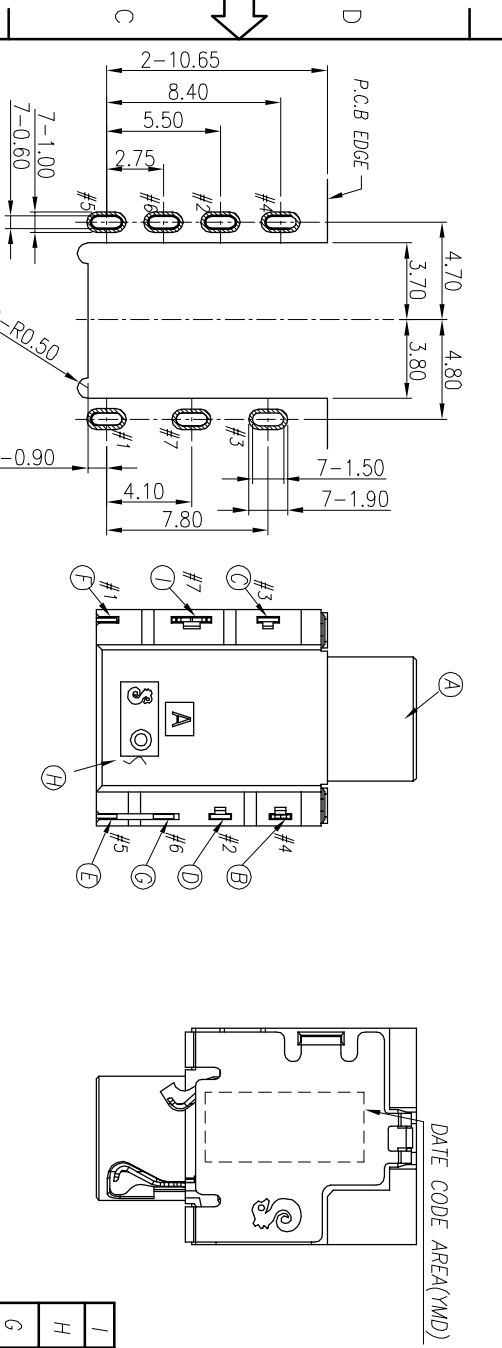

NO	DESCRIPTION	QTY	MATERIAL	PLATING & COLOR
I	SHELL	1	COPPER ALLOY, 0.2t	Ni 60u Min.
H	SEPARATOR	1	HIGH TEMP.THERMOPLASTIC UL 94V-0	BLACK
G	MAKE-TERMINAL	1	COPPER ALLOY, 0.2t	GOLD FLASH ON CONTACT AREA, GOLD FLASH ON SOLDER AREA, ALL OVER 50u Ni.
F	TIP-SPRING	1	STAINLESS STEEL, 0.2t	
E	TRANSFER-TERMINAL	1	COPPER ALLOY, 0.2t	GOLD FLASH ON CONTACT AREA, GOLD FLASH ON SOLDER AREA, ALL OVER 50u Ni.
D	RING-A	1	COPPER ALLOY, 0.2t	Matte 5880° ON SOLDER AREA.
C	RING-B	1	COPPER ALLOY, 0.2t	ALL OVER 50u Ni.
B	EARTH	1	COPPER ALLOY, 0.2t	
A	BODY	1	HIGH TEMP.THERMOPLASTIC UL 94V-0	BLACK



NO	DESCRIPTION	QTY	MATERIAL	PLATING & COLOR
A	BODY	1	HIGH TEMP.THERMOPLASTIC UL 94V-0	BLACK

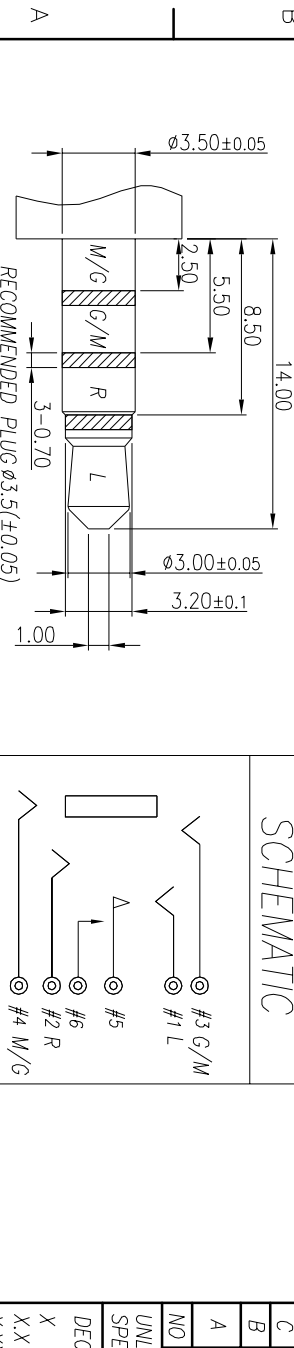

NO	DESCRIPTION	QTY	MATERIAL	PLATING & COLOR
A	BODY	1	HIGH TEMP.THERMOPLASTIC UL 94V-0	BLACK

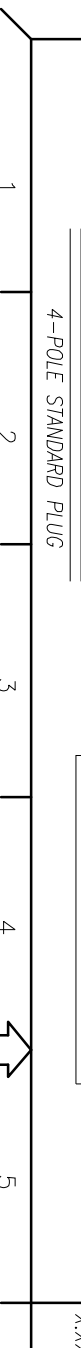

NO	DESCRIPTION	QTY	MATERIAL	PLATING & COLOR
A	BODY	1	HIGH TEMP.THERMOPLASTIC UL 94V-0	BLACK

4-POLE STANDARD PLUG

NO	DESCRIPTION	QTY	MATERIAL	PLATING & COLOR
A	BODY	1	HIGH TEMP.THERMOPLASTIC UL 94V-0	BLACK

3.50 AUDIO JACK

信亨企業股份有限公司

DMN Guorong
CHKD Bruce
APVD Liao

PART NO. 25J3080-168111F
SCALE 4:1
SIZE: A3

UNIT: mm
SHEET: 1 OF 1
REV: A

CUSTOMER COPY

REV. 00-06-043-A