

REV.	ECN NO OR DESCRIPTION	REVISED	DATE
A	PDR NO: T151209-10A	Peng	2016.04.06
B	ECN NO: S160535-C	JIE-FU	2016.06.30

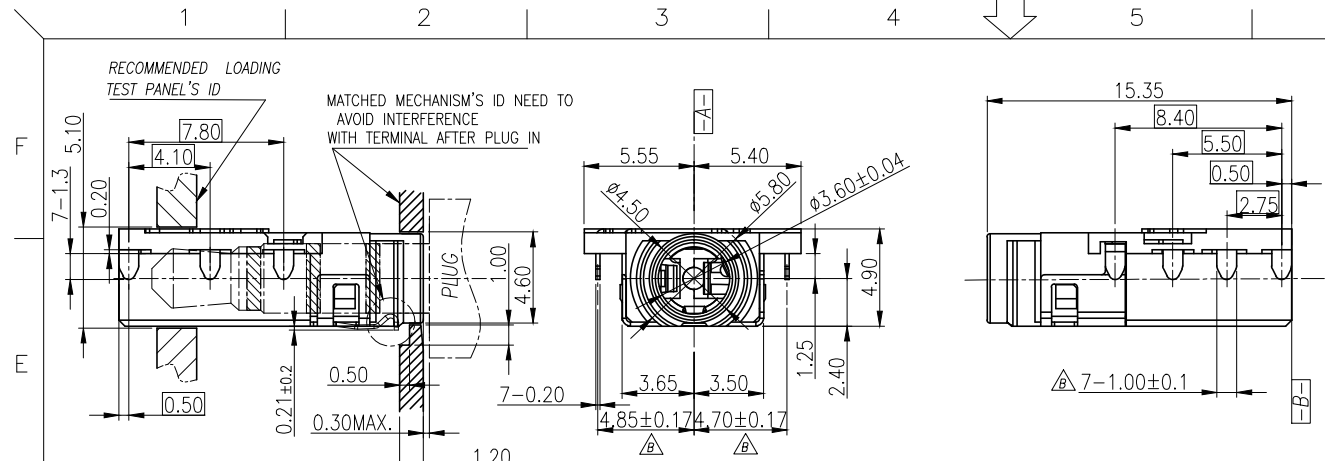

- SPECIFICATIONS:
- INSULATION RESISTANCE BETWEEN ANY ADJACENT OPEN CIRCUIT TERMINAL SHELL NOT BE LESS THAN 100MΩ MEASURED BY 500 VDC .
 - CONTACT RESISTANCE: 50mΩ MAX.
 - INSULATION VOLTAGE WITHSTAND:500V AC FOR ONE MINUTE.
 - UNLESS OTHERWISE SPECIFIED, TEST IS TO BE MADE AT 5-35°C IN TEMPERATURE AND 45-85% IN HUMIDITY. BUT,IF ANY VAGUE DATA IS OCCURED ON TEST RESULT, ANOTHER TEST SHALL BE MADE AT 20°C±2°C IN TEMP., 60-70% IN HUMIDITY.
 - LIFE TEST: 5,000 CYCLES.
 - INSERTION FORCE: 0.3 - 3.0Kg.
 - WITHDRAWAL FORCE: 0.3 - 3.0Kg.
 - AFTER TEST, CONTACT RESISTANCE: 120mΩ MAX.
 - AFTER HUMIDITY TEST, INSULATION RESISTANCE: 50MΩ MIN.
 - MARKING: MARK "S" ON BOTTOM OF CONNECTOR.
 - PACKING : TAPE & REEL.
 - TO CONFORM TO SINGATRON HAZARDOUS SUBSTANCE FREE SPEC.
 - HALOGEN FREE PRODUCT IDENTIFICATION MARK ON JACK:
 - HALOGEN FREE PRODUCT IDENTIFICATION LABEL ON PACKAGING:

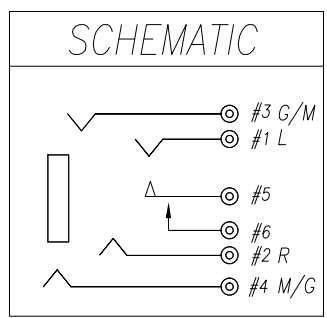
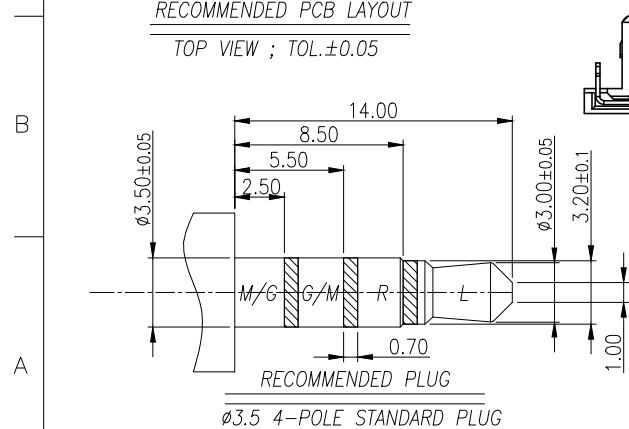
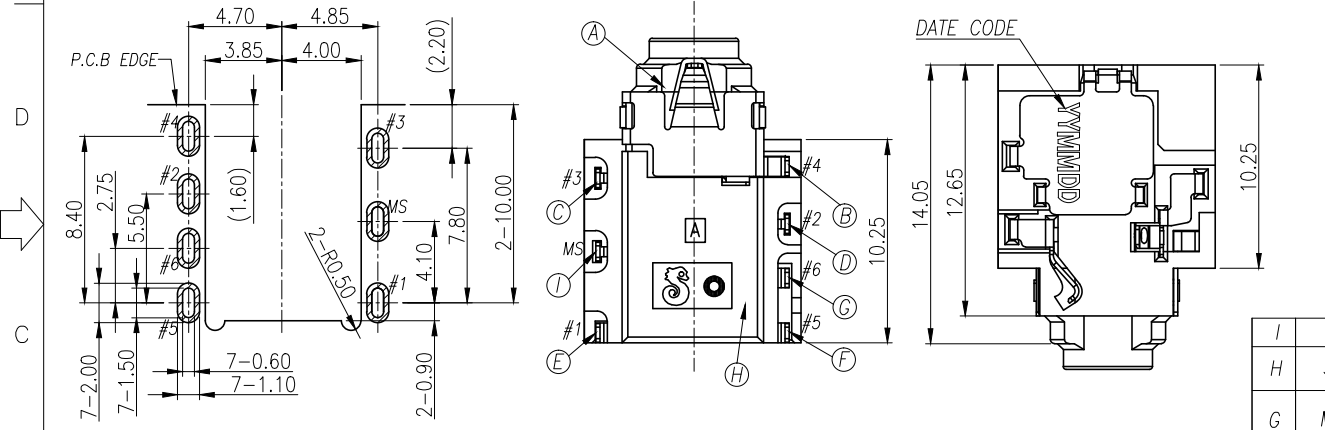

I	SHELL	1	COPPER ALLOY, 0.2t	Ni 60u"Min.																								
H	SEPARATOR	1	HIGH TEMP.THERMOPLASTIC UL 94V-0	BLACK																								
G	MAKE TERMINAL	1	COPPER ALLOY, 0.2t	GOLD FLASH ON CONTACT AREA; GOLD FLASH ON SOLDER AREA; ALL OVER 50u" Ni.																								
F	TRANSFER TERMINAL	1	COPPER ALLOY, 0.2t	GOLD FLASH ON CONTACT AREA; Matte Sn 80u" ON SOLDER AREA; ALL OVER 50u" Ni.																								
E	TIP SPRING	1	COPPER ALLOY, 0.2t																									
D	RING A	1	COPPER ALLOY, 0.2t																									
C	RING B	1	COPPER ALLOY, 0.2t	BLACK																								
B	EARTH	1	COPPER ALLOY, 0.2t																									
A	BODY	1	PA4T+30%GF TiTX1-BK UL 94V-0 無鹵	BLACK																								
NO	DESCRIPTION	QTY	MATERIAL	PLATING & COLOR																								
UNLESS OTHERWISE SPECIFIED TOLERANCES		Singatron Enterprise Co., Ltd. 信音企業股份有限公司																										
DECIMALS: X :±0.5 X.X :±0.3 X.XX :±0.2		ANGLES: X :±2° X.X :±1°		<table border="1"> <thead> <tr> <th colspan="4">TITLE</th> </tr> <tr> <th colspan="4">3.5ø PHONE JACK</th> </tr> </thead> <tbody> <tr> <td>DWN</td> <td>JIE-FU</td> <td colspan="2">PART NO. 2SJ3095-107111F</td> </tr> <tr> <td>CHKD</td> <td>CERRY</td> <td>SCALE 4:1</td> <td>UNIT: mm</td> </tr> <tr> <td>APVD</td> <td>LUSSEN</td> <td>SIZE: A3</td> <td>SHEET:1 OF 1</td> </tr> <tr> <td colspan="4" style="text-align: right;">REV: B</td> </tr> </tbody> </table>	TITLE				3.5ø PHONE JACK				DWN	JIE-FU	PART NO. 2SJ3095-107111F		CHKD	CERRY	SCALE 4:1	UNIT: mm	APVD	LUSSEN	SIZE: A3	SHEET:1 OF 1	REV: B			
TITLE																												
3.5ø PHONE JACK																												
DWN	JIE-FU	PART NO. 2SJ3095-107111F																										
CHKD	CERRY	SCALE 4:1	UNIT: mm																									
APVD	LUSSEN	SIZE: A3	SHEET:1 OF 1																									
REV: B																												
CUSTOMER COPY																												