

REV.	ECN NO OR DESCRIPTION	REVISED	DATE
A	PDR NO: T160226-4A	ROBIN	2016.09.20

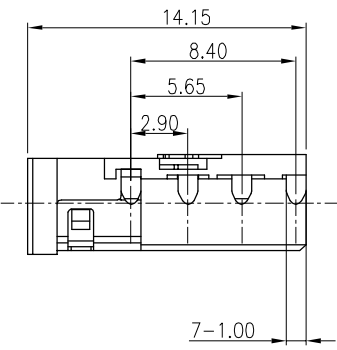

- SPECIFICATIONS:**
- INSULATION RESISTANCE BETWEEN ANY ADJACENT OPEN CIRCUIT TERMINAL SHELL NOT BE LESS THAN 100MΩ MEASURED BY 500 VDC.
 - CONTACT RESISTANCE: 50mΩ MAX.
 - INSULATION VOLTAGE WITHSTAND: 500V AC FOR ONE MINUTE.
 - UNLESS OTHERWISE SPECIFIED, TEST IS TO BE MADE AT 5-35°C IN TEMPERATURE AND 45-85% IN HUMIDITY. BUT, IF ANY VAGUE DATA IS OCCURED ON TEST RESULT, ANOTHER TEST SHALL BE MADE AT 20°C±2°C IN TEMP., 60-70% IN HUMIDITY.
 - LIFE TEST: 5,000 CYCLES.
 - INSERTION FORCE: 0.3 - 3.0Kg.
 - WITHDRAWAL FORCE: 0.3 - 3.0Kg.
 - AFTER TEST, CONTACT RESISTANCE: 120mΩ MAX.
 - AFTER HUMIDITY TEST, INSULATION RESISTANCE: 50MΩ MIN.
 - MARKING: MARK "S" ON TOP OF CONNECTOR.
 - PACKING : TAPE & REEL.
 - TO CONFORM TO SINGATRON HAZARDOUS SUBSTANCE FREE SPEC.
 - HALOGEN FREE PRODUCT IDENTIFICATION MARK ON JACK:
 - HALOGEN FREE PRODUCT IDENTIFICATION LABEL ON PACKAGING:

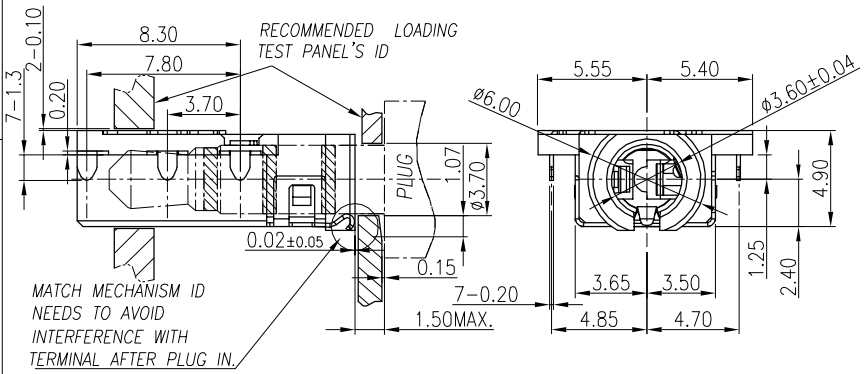
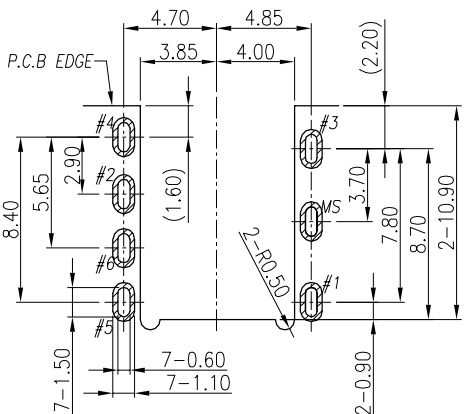

RECOMMENDED PCB LAYOUT
TOP VIEW ; TOL.±0.05

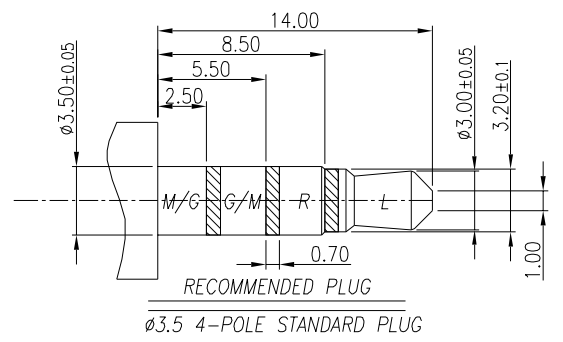
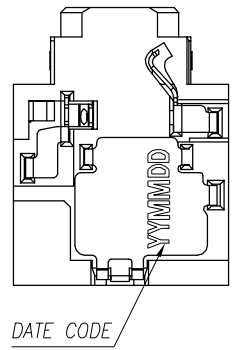
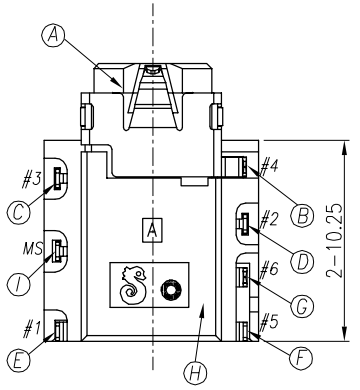

RECOMMENDED PLUG
ø3.5 4-POLE STANDARD PLUG

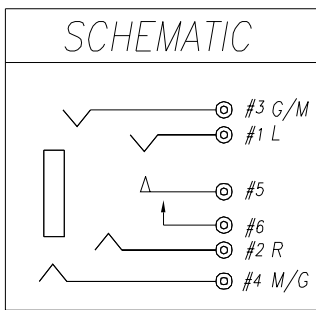

I	SHELL	1	COPPER ALLOY, 0.2t	Ni 60u"Min.
H	SEPARATOR	1	HIGH TEMP.THERMOPLASTIC UL 94V-0	BLACK
G	MAKE TERMINAL	1	COPPER ALLOY, 0.2t	GOLD FLASH ON CONTACT AREA; GOLD FLASH ON SOLDER AREA; ALL OVER 50u" Ni.
F	TRANSFER TERMINAL	1	COPPER ALLOY, 0.2t	GOLD FLASH ON CONTACT AREA;
E	TIP SPRING	1	COPPER ALLOY, 0.2t	Matte Sn 80u" ON SOLDER AREA;
D	RING A	1	COPPER ALLOY, 0.2t	ALL OVER 50u" Ni.
C	RING B	1	COPPER ALLOY, 0.2t	
B	EARTH	1	COPPER ALLOY, 0.2t	GOLD FLASH ON CONTACT AREA; GOLD FLASH ON SOLDER AREA; ALL OVER 50u" Ni.
A	BODY	1	PA4T UL 94V-0	BLACK
NO	DESCRIPTION	QTY	MATERIAL	PLATING & COLOR

UNLESS OTHERWISE SPECIFIED TOLERANCES

Singatron Enterprise Co., Ltd.
信音企業股份有限公司

DECIMALS:	ANGLES:	TITLE	3.5ø PHONE JACK		
X : ±0.5	X : ±2°	DWN	ROBIN	PART NO. 2SJ3095-126111F	
X.X : ±0.3	X.X : ±1°	CHKD	BRUCE	SCALE 4:1	UNIT: mm
X.XX : ±0.2		APVD	LUSSEN	SIZE: A3	SHEET: 1 OF 1

CUSTOMER COPY