

REV.	ECN NO OR DESCRIPTION	REVISED	DATE
A	PDR NO:T180209-4A,T180209-4B	RAINY	2018.08.30

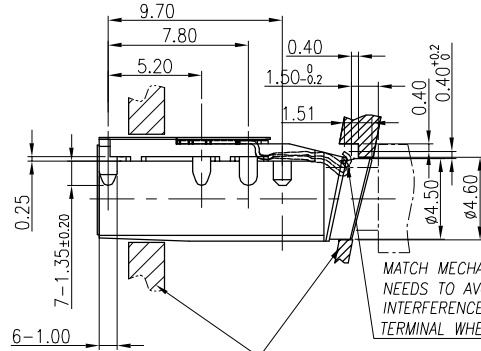

RECOMMENDED LIMIT STRUCTURE

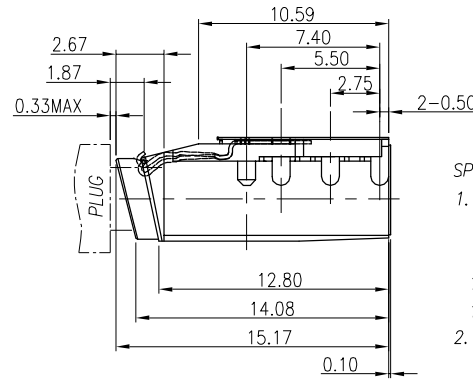
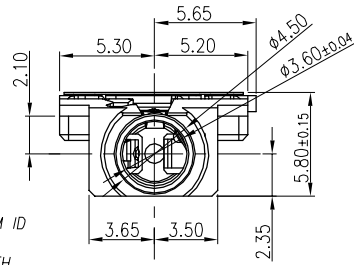

SPECIFICATIONS:

- ELECTRICAL CHARACTERISTICS:
  - RATING: 12V 1A
  - CONTACT RESISTANCE: 50mΩ MAX.(INITIAL)
  - DIELECTRIC WITHSTANDING VOLTAGE: 500V AC FOR ONE MINUTE.
  - INSULATION RESISTANCE: 100MΩ MIN. MEASURED BY 500 VDC.
- MECHANICAL CHARACTERISTICS:
  - INITIAL: INSERTION FORCE: 0.8 - 3.0Kgf. WITHDRAWAL FORCE: 0.6 - 1.8Kgf.
  - AFTER 2000 TIMES INSERTION FORCE: 2.5Kgf Max. WITHDRAWAL FORCE: 0.5Kgf Min.
- LIFE TEST: 2,000 CYCLES . AFTER LIFE TEST, CONTACT RESISTANCE: 120mΩ MAX.
- PACKAGING : TAPE & REEL.
- AFTER HUMIDITY TEST, INSULATION RESISTANCE: 50MΩ MIN.
- OTHER GENERAL SPEC TO REFER "AUDIO JACK FOR 2SJ3095-184X11F SPEC"
- TO CONFORM TO SINGATRON HAZARDOUS SUBSTANCE FREE SPEC.
- HALOGEN FREE PRODUCT IDENTIFICATION MARK ON PRODUCT:
- HALOGEN FREE PRODUCT IDENTIFICATION LOGO ON PACKAGING:

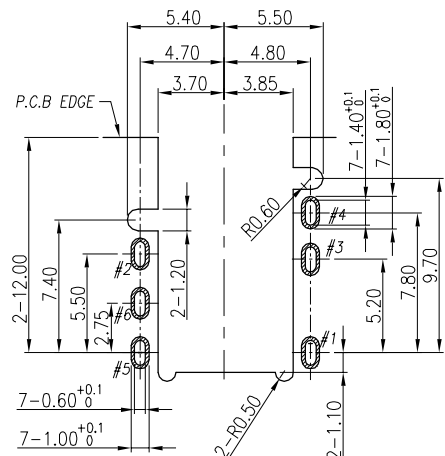

RECOMMENDED PCB LAYOUT  
TOP VIEW ; TOL.±0.05

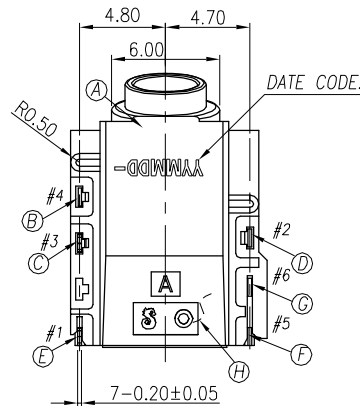
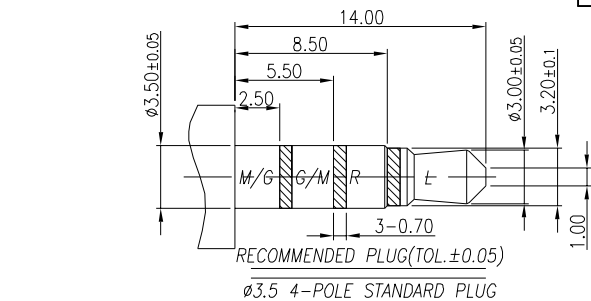
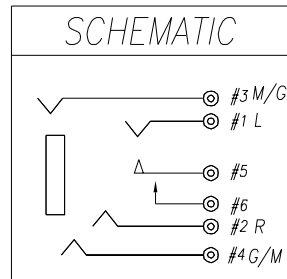

TABLE 1 :

P/N	PLATING SPEC
2SJ3095-184111F	GOLD FLASH ON CONTACT AREA;
2SJ3095-184211F	Au 30u" Min. ON CONTACT AREA



RECOMMENDED PLUG(TOL.±0.05)  
Ø3.5 4-POLE STANDARD PLUG



NO	DESCRIPTION	QTY	MATERIAL	PLATING & COLOR
K	MYLAR	1	T=0.10	YELLOW
J	MYLAR	1	T=0.10	YELLOW
H	SEPARATOR	1	HIGH TEMP.THERMOPLASTIC UL 94V-0	BLACK
G	MAKE TERMINAL	1	PHOSPHOR BRONZE 0.2t	GOLD FLASH ON CONTACT AREA; GOLD FLASH ON SOLDER AREA; ALL OVER 50u" Ni.
F	TRANSFER TERMINAL	1	PHOSPHOR BRONZE 0.2t	GOLD FLASH ON CONTACT AREA; Mottle Sn80u" ON SOLDER AREA; ALL OVER 50u" Ni.
E	TIP SPRING	1	STAINLESS STEEL 0.2t	G/F OR Au 30u" ON CONTACT AREA; GOLD FLASH ON SOLDER AREA; ALL OVER 50u" Ni.
D	RING A	1	PHOSPHOR BRONZE 0.2t	G/F OR Au 30u" ON CONTACT AREA;
C	EARTH	1	PHOSPHOR BRONZE 0.2t	Mottle Sn80u" ON SOLDER AREA; ALL OVER 50u" Ni.
B	RING B	1	PHOSPHOR BRONZE 0.2t	
A	BODY	1	HIGH TEMP.THERMOPLASTIC UL 94V-0	BLACK

UNLESS OTHERWISE SPECIFIED TOLERANCES

Singatron Enterprise Co., Ltd.  
信音企業股份有限公司

DECIMALS:	ANGLES:	TITLE	Ø3.50 AUDIO JACK		
X : ±0.5	X : ±2°	DWN	RAINY	PART NO. 2SJ3095-184X11F	
X.X : ±0.3	X.X : ±1°	CHKD	BRUCE	SCALE 4:1	UNIT: mm
X.XX : ±0.2		APVD	LIAO	SIZE: A3	SHEET: 1 OF 1
					REV: A

CUSTOMER COPY