

MATCH MECHANISM ID NEEDS TO AVOID INTERFERENCE WITH TERMINAL AFTER PLUG IN.

RECOMMENDED TEST PANEL'S ID

SPECIFICATIONS:

- INSULATION RESISTANCE BETWEEN ANY ADJACENT OPEN CIRCUIT TERMINAL SHELL NOT BE LESS THAN 100MΩ MEASURED BY 500V DC.
- CONTACT RESISTANCE: 50mΩ MAX(INITIAL).
- INSULATION VOLTAGE WITHSTAND: 500V AC FOR ONE MINUTE.
- MECHANICAL CHARACTERISTICS:
 - INSERTION FORCE: 0.8~3.0kgf INITIAL; 2.5 kgf Max. After THE 2000th; 0.3 kgf Min. AFTER LIFE TEST;
 - WITHDRAWAL FORCE: 0.6~1.8kgf INITIAL; 0.5 kgf Min. After THE 2000th; 0.3 kgf Min. AFTER LIFE TEST;
- LIFE TEST: 5,000 CYCLES Min. AFTER LIFE TEST, CONTACT RESISTANCE: 100mΩ MAX.
- AFTER HUMIDITY TEST, INSULATION RESISTANCE: 50MΩ MIN.
- MARKING: MARK "S" ON TOP OF CONNECTOR.
- PACKING: TAPE & REEL.
- TO CONFORM TO SINGATRON HAZARDOUS SUBSTANCE FREE SPEC.
- TO CONFORM TO SINGATRON IDENTIFICATION MARK ON PRODUCT.
- HALOGEN FREE PRODUCT IDENTIFICATION MARK ON PRODUCT.
- HALOGEN FREE PRODUCT IDENTIFICATION LOGO ON PACKAGING.

REV.	EGN NO.	OR DESCRIPTION	REVISED	DATE
A	PDR NO: T160606-6A		Julia	2016.11.21

RECOMMENDED PCB LAYOUT
TOP VIEW ; TOL. ±0.05

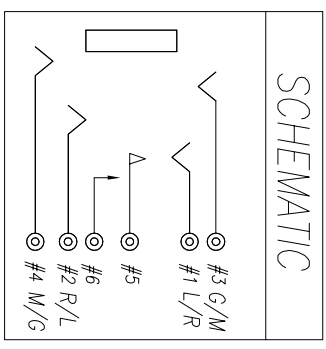
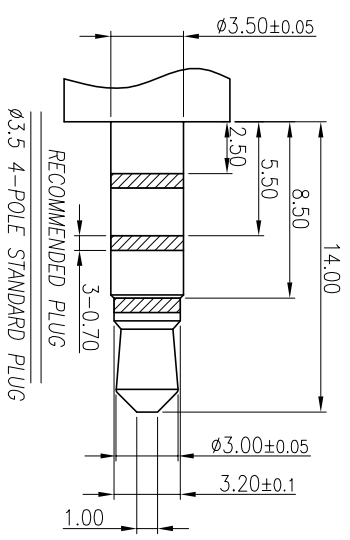

NO	DESCRIPTION	QTY	MATERIAL	PLATING & COLOR
I	MYLAR	1	6.6W*12.8L*0.1T	BROWN
H	SEPARATOR	1	TOP E130I +30% GF UL 94V-0	BLACK
G	MAKE TERMINAL	1	C5210-EH 0.20T	GOLD FLASH ON CONTACT AREA GOLD FLASH ON SOLDER AREA ALL OVER 50μ IN.
F	TRANSFER TERMINAL	1	C5210-EH 0.20T	
E	TIP SPRING	1	C5210-EH 0.20T	
D	RING A	1	C5210-EH 0.20T	
C	RING B	1	C5210-EH 0.20T	
B	EARTH	1	C5210-EH 0.20T	
A	BODY	1	PA4T(TX1)+30% GF UL 94V-0	BLACK
UNLESS OTHERWISE SPECIFIED TOLERANCES				
DECIMALS:		ANGLES:		
X	:±0.5	X	:±2°	
X.X	:±0.3	X.X	:±1°	
X.XX	:±0.2			
TITLE		Ø3.50 AUDIO JACK		
DWG		Julia		
CHKD		Bruce		
APVD		Lussen		
PART NO.		2S13098-013111F		
SCALE		4:1		
UNIT		mm		
SHEET		1 OF 1		
REV		A		

Singatron Enterprise Co., Ltd.
信登企業股份有限公司

CUSTOMER COPY