

REV. ECN NO. OR DESCRIPTION	REVISED	DATE
A PDR NO: T190815-1A	Peng	2020.07.22

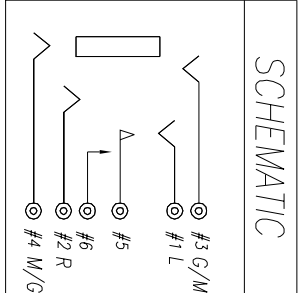
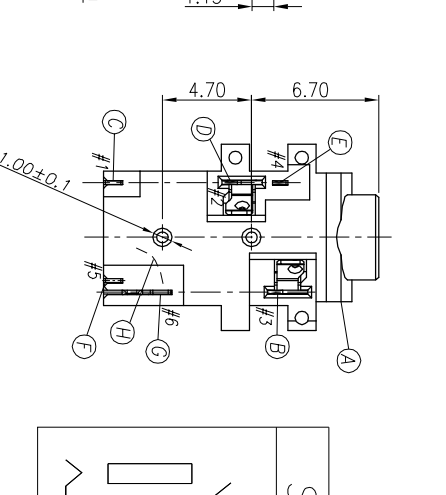
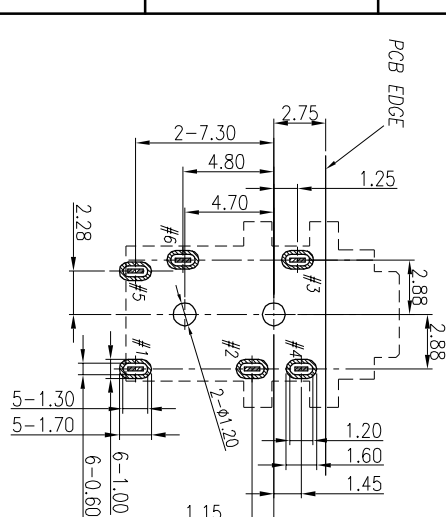
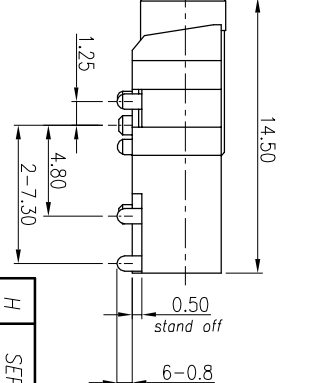
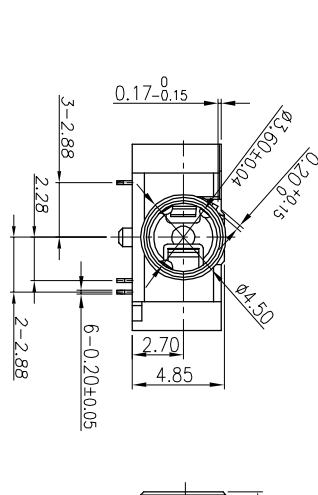
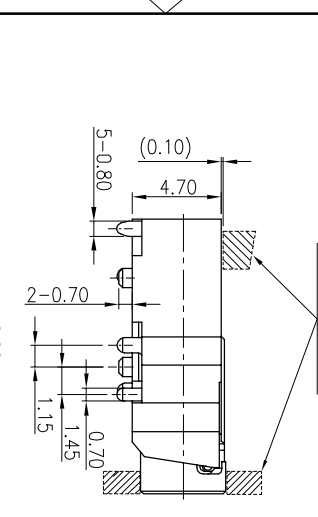
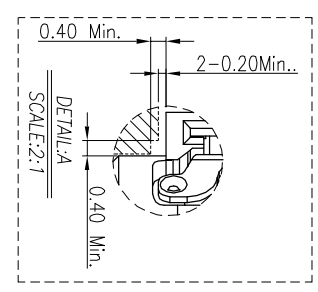
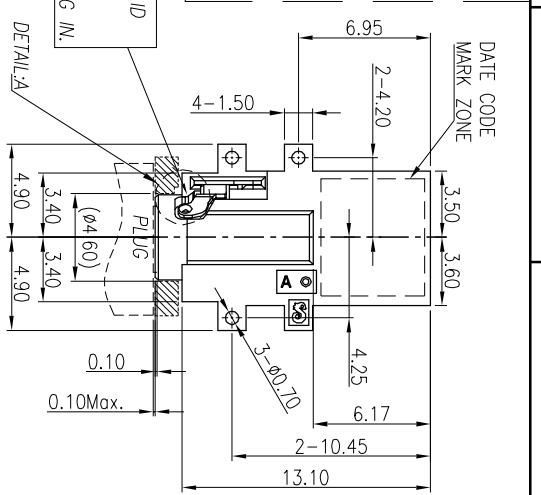
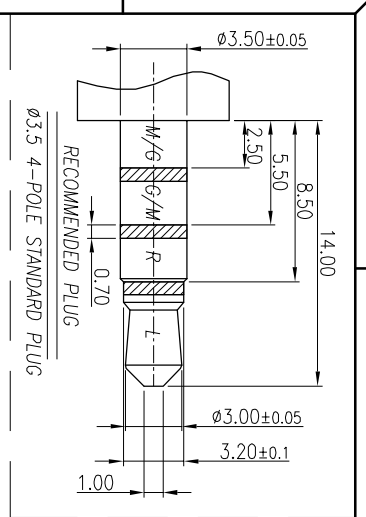

- SPECIFICATIONS:
- ELECTRICAL CHARACTERISTICS:
    - RATING: 12V 1A
    - CONTACT RESISTANCE: 50mΩ MAX.(INITIAL)
    - DIELECTRIC WITHSTANDING VOLTAGE: 500V AC FOR ONE MINUTE.
    - INSULATION RESISTANCE: 100MΩ MIN. MEASURED BY 500 VDC.
  - LIFE TEST: 2,000 CYCLES MIN. AFTER LIFE TEST, CONTACT RESISTANCE: 100mΩ MAX.
  - MECHANICAL CHARACTERISTICS:
    - BEFORE LIFE TEST: INSERTION FORCE: 0.8-3.0 Kgf, EXTRACTION FORCE: 0.6-1.8 Kgf,
    - AFTER LIFE TEST: INSERTION FORCE: 2.5 Kgf MAX, EXTRACTION FORCE: 0.5 Kgf MIN.
  - PACKAGING : TAPE & REEL.
  - AFTER HUMIDITY TEST, INSULATION RESISTANCE: 50MΩ MIN.
  - TO CONFORM TO SINGATRON HAZARDOUS SUBSTANCE FREE SPEC.
  - HALOGEN FREE PRODUCT IDENTIFICATION MARK ON PRODUCT.
  - HALOGEN FREE PRODUCT IDENTIFICATION LOGO ON PACKAGING.
  - FOR LEAD-FREE PROCESS.
  - PRINTED DATE CODE "YMD" ON TOP OF CONNECTOR.

H	SEPARATOR	1	HIGH TEMP.THERMOPLASTIC UL 94V-0	BLACK
G	MAKE TERMINAL	1	PHOSPHOR BRONZE 0.2t	GOLD FLASH ON CONTACT AREA, GOLD FLASH ON SOLDER AREA, ALL OVER 50μ Ni.
F	TRANSFER TERMINAL	1	PHOSPHOR BRONZE 0.2t	4μ 30μ ON CONTACT AREA, GOLD FLASH ON SOLDER AREA, ALL OVER 50μ Ni.
E	EARTH	1	PHOSPHOR BRONZE 0.2t	4μ 30μ ON CONTACT AREA, GOLD FLASH ON SOLDER AREA, ALL OVER 50μ Ni.
D	RING A	1	PHOSPHOR BRONZE 0.2t	4μ 30μ ON CONTACT AREA, GOLD FLASH ON SOLDER AREA, ALL OVER 50μ Ni.
C	TIP SPRING	1	STAINLESS STEEL 0.2t	
B	RING B	1	PHOSPHOR BRONZE 0.2t	4μ 30μ ON CONTACT AREA, GOLD FLASH ON SOLDER AREA, ALL OVER 50μ Ni.
A	BODY	1	HIGH TEMP.THERMOPLASTIC UL 94V-0	BLACK
NO	DESCRIPTION	QTY	MATERIAL	PLATING & COLOR

UNLESS OTHERWISE SPECIFIED TOLERANCES

DECIMALS: ANGLES:

X :±0.5 X :±2°  
 X.X :±0.3 X.X :±1°  
 X.XX :±0.2

RECOMMENDED PCB LAYOUT  
 TOP VIEW ; TOL.±0.05

Singatron Enterprise Co., Ltd.  
 信晉企業股份有限公司  
 TITLE: Ø3.50 AUDIO JACK  
 DWG: Peng PART NO.2SJ3098-034111F  
 CHKD: Bruce SCALE 4:1 UNIT: mm  
 APVD: Liao SIZE: A3 SHEET:1 OF 1 REV: A  
 CUSTOMER COPY