

REV.	ECN NO OR DESCRIPTION	REVISED	DATE
A	PDR NO: T150611-2A	Peng	2015.10.26
B	ECN NO: S160149-C	JIE-FU	2016.03.11

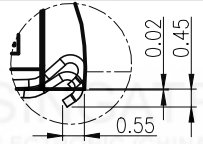

DETAIL:A
SCALE:2:1
PRODUCT APPLICATION:
THE SPRING WORKING
POSITION WHEN PLUG-IN

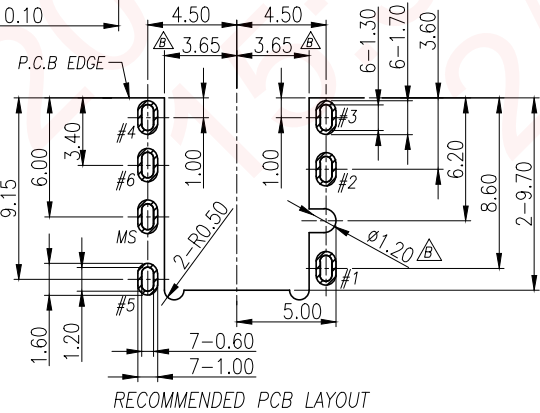
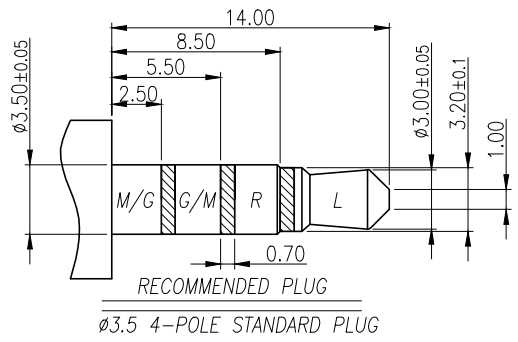
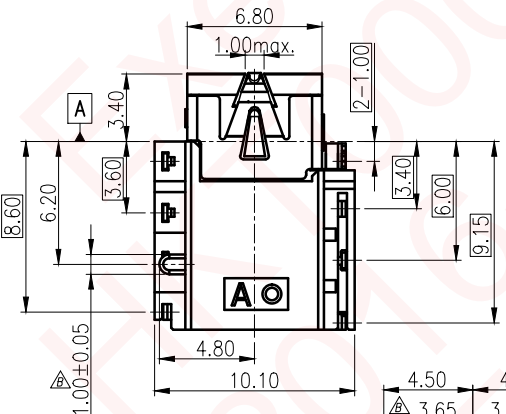
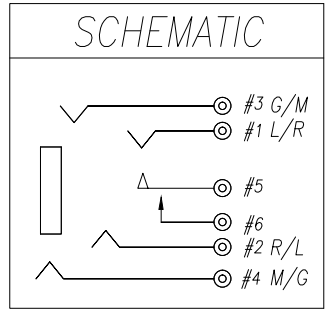
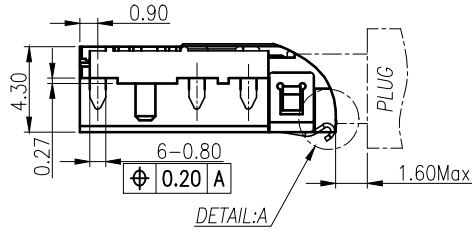
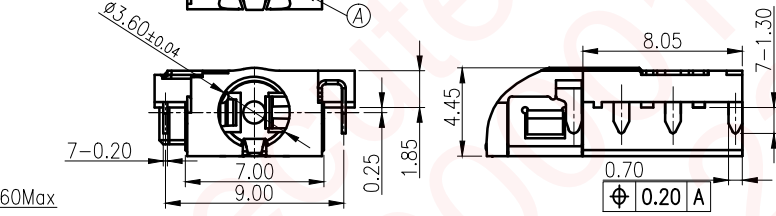
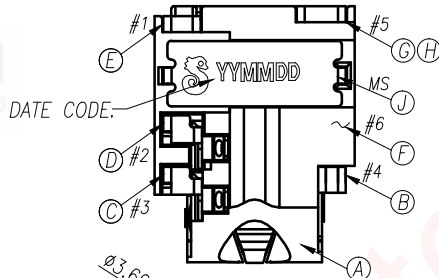

SPECIFICATIONS:

- INSULATION RESISTANCE BETWEEN ANY ADJACENT OPEN CIRCUIT TERMINAL SHELL NOT BE LESS THAN 100MΩ MEASURED BY 500 VDC.
- CONTACT RESISTANCE: 50mΩ MAX(INITIAL).
- INSULATION VOLTAGE WITHSTAND:500V AC FOR ONE MINUTE.
- UNLESS OTHERWISE SPECIFIED. TEST IS TO BE MADE AT 5-35°C IN TEMPERATURE AND 45-85% IN HUMIDITY. BUT,IF ANY VAGUE DATA IS OCCURED ON TEST RESULT, ANOTHER TEST SHALL BE MADE AT 20°C±2°C IN TEMP., 60-70% IN HUMIDITY.
- LIFE TEST: 5,000 CYCLES MIN.
- INSERTION FORCE: 0.3 - 3Kg.
- WITHDRAWAL FORCE: 0.2 - 3Kg (INITIAL)..
- AFTER LIFE TEST, CONTACT RESISTANCE: 100mΩ MAX.
- AFTER HUMIDITY TEST, INSULATION RESISTANCE: 50MΩ MIN.
- MARKING: MARK "S" ON TOP OF CONNECTOR.
- PACKING : TAPE & REEL.
- TO CONFORM TO SINGATRON HAZARDOUS SUBSTANCE FREE SPEC.
- HALOGEN FREE PRODUCT IDENTIFICATION MARK ON PRODUCT:
- HALOGEN FREE PRODUCT IDENTIFICATION LOGO ON PACKAGING:

J	SHELL	1	SUS304-1/2H 0.2t	Ni 60u"Min.
H	SEPARATOR	1	HIGH TEMP.THERMOPLASTIC UL 94V-0	BLACK
G	TRANSFER TERMINAL	1	PHOSPHOR BRONZE 0.2t	GOLD FLASH ON CONTACT AREA; GOLD FLASH ON SOLDER AREA; ALL OVER 50u" Ni.
F	MAKE TERMINAL	1	PHOSPHOR BRONZE 0.2t	GOLD FLASH ON CONTACT AREA; Matte Sn80u" ON SOLDER AREA; ALL OVER 50u" Ni.
E	TIP SPRING	1	PHOSPHOR BRONZE 0.2t	
D	RING A	1	PHOSPHOR BRONZE 0.2t	
C	RING B	1	PHOSPHOR BRONZE 0.2t	
B	EARTH	1	PHOSPHOR BRONZE 0.2t	
A	BODY	1	HIGH TEMP.THERMOPLASTIC UL 94V-0	BLACK
NO	DESCRIPTION	QTY	MATERIAL	PLATING & COLOR

UNLESS OTHERWISE SPECIFIED TOLERANCES		Singatron Enterprise Co., Ltd. 信音企業股份有限公司	
DECIMALS:	ANGLES:	TITLE 3.5Φ PHONE JACK	
X :±0.5	X :±2°	DWN	JIE-FU PART NO.2SJ3108-049111F
X.X :±0.3	X.X :±1°	CHKD	CERRY SCALE 4:1 UNIT: mm
X.XX :±0.2		APVD	LUSSEN SIZE: A3 SHEET:1 OF 1 REV:B
CUSTOMER COPY			

TOP VIEW : TOL.±0.05