

REV.	ECN NO OR DESCRIPTION	REVISED	DATE
A	PDR NO: S170307-2A	Ming	2017.09.12
B	ECN NO: S202004-E16	Jinshuai	2020.06.19

**SPECIFICATIONS:**

- INSULATION RESISTANCE BETWEEN ANY ADJACENT OPEN CIRCUIT TERMINAL SHELL NOT BE LESS THAN 100MΩ MEASURED BY 500 VDC.
- CONTACT RESISTANCE: 50mΩ MAX(INITIAL).
- INSULATION VOLTAGE WITHSTAND: 500V AC FOR ONE MINUTE.
- UNLESS OTHERWISE SPECIFIED, TEST IS TO BE MADE AT 5-35°C IN TEMPERATURE AND 45-85% IN HUMIDITY. BUT IF ANY VAGUE DATA IS OCCURED ON TEST RESULT, ANOTHER TEST SHALL BE MADE AT 20°C±2°C IN TEMP., 60-70% IN HUMIDITY.
- LIFE TEST: 5,000 CYCLES MIN.
- INSERTION FORCE: 0.3 - 3kg.
- WITHDRAWAL FORCE: 0.4kg MIN.
- AFTER LIFE TEST, CONTACT RESISTANCE: 100mΩ MAX.
- AFTER HUMIDITY TEST, INSULATION RESISTANCE: 50MΩ MIN.
- MARKING: MARK (A) ON TOP OF CONNECTOR.
- PACKING: TAPE & REEL.
- TO CONFORM TO SINGATRON HAZARDOUS SUBSTANCE FREE SPEC.
- HALOGEN FREE PRODUCT IDENTIFICATION MARK ON PRODUCT: (B)
- HALOGEN FREE PRODUCT IDENTIFICATION LOGO ON PACKAGING: (C)
- PRINTED DATE CODE "MMDD=" ON TOP OF CONNECTOR.

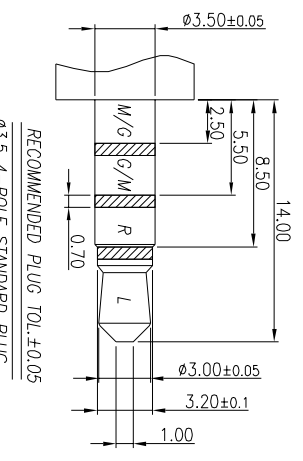
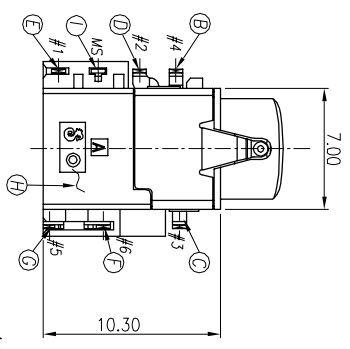
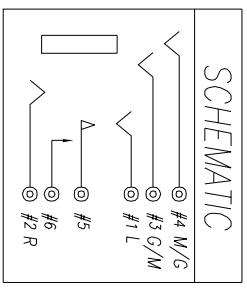
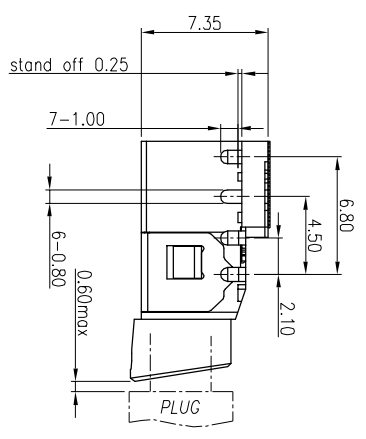
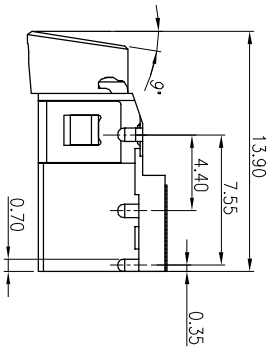
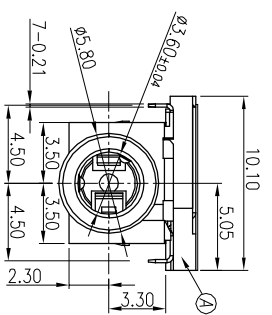
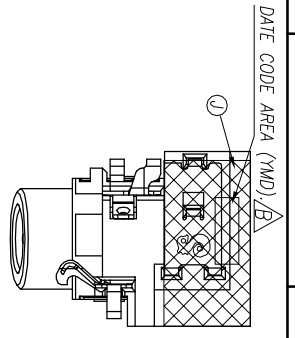

RECOMMENDED PLUG TOL.±0.05  
0.3.5 4-POLE STANDARD PLUG

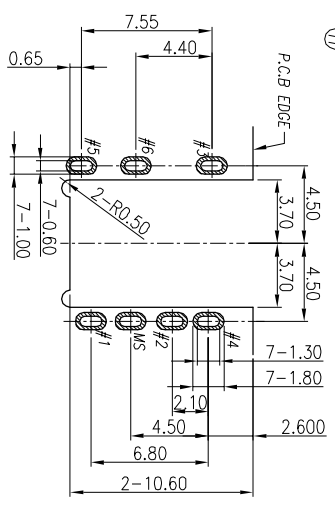

RECOMMENDED PCB LAYOUT  
TOP VIEW: TOL.±0.05

NO	DESCRIPTION	QTY	MATERIAL	PLATING & COLOR
J	MYLAR	1	KAPTON 0.10t	BROWN
I	SHELL	1	SUS304-1/2H 0.2t	Ni 60μ Min.
H	SEPARATOR	1	HIGH TEMP.THERMOPLASTIC UL 94V-0	BLACK
G	TRANSFER TERMINAL	1	PHOSPHOR BRONZE 0.2t	Au 1-3μ ON CONTACT AREA Au 1-3μ ON SOLDER AREA
F	MAKE TERMINAL	1	PHOSPHOR BRONZE 0.2t	Au 1-3μ ON CONTACT AREA Au 1-3μ ON SOLDER AREA
E	TIP SPRING	1	SUS304-1/2H 0.2t	Au 5μ ON CONTACT AREA Au 1-3μ ON SOLDER AREA ALL OVER 50μ Ni
D	RING A	1	PHOSPHOR BRONZE 0.2t	Au 5μ ON CONTACT AREA
C	RING B	1	PHOSPHOR BRONZE 0.2t	Au 5μ ON CONTACT AREA
B	EARTH	1	PHOSPHOR BRONZE 0.2t	ALL OVER 50μ Ni
A	BODY	1	HIGH TEMP.THERMOPLASTIC UL 94V-0	BLACK
NO	DESCRIPTION	QTY	MATERIAL	PLATING & COLOR

UNLESS OTHERWISE SPECIFIED TOLERANCES

DECIMALS: ANGLES:  
X :±0.5 X :±2°  
X.X :±0.3 X.X :±1°  
X.XX :±0.2

TITLE	3.5Φ PHONE JACK
DWN	Jinshuai PART NO.2S13108-097111F
CHKD	Bruce SCALE 4:1 UNIT: mm
APVD	LIAO SIZE: A3 SHEET: 1 OF 1 REV: B

CUSTOMER COPY

Singatron Enterprise Co., Ltd.  
信登企業股份有限公司