

REV.	ECN NO OR DESCRIPTION	REVISED	DATE
A	PDR NO:T170330-8A	Ming	2017.08.15

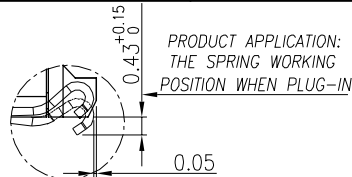

DETAIL:A
SCALE:2:1

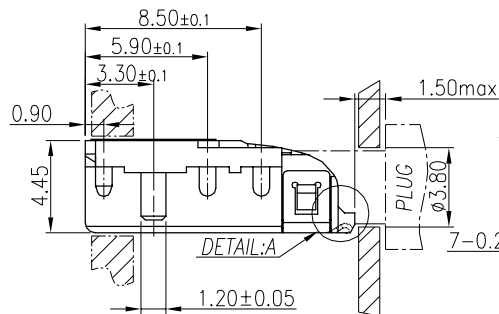

SCHEMATIC

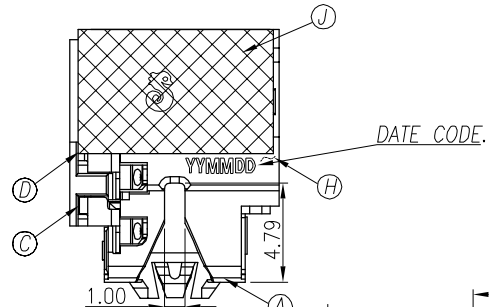
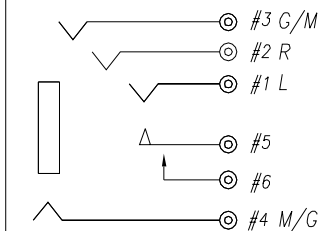

DATE CODE.

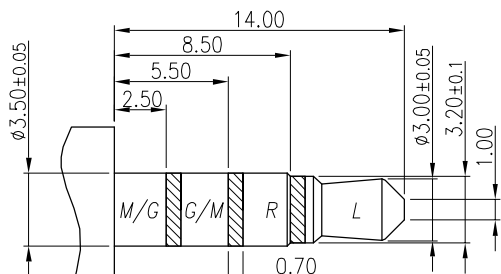
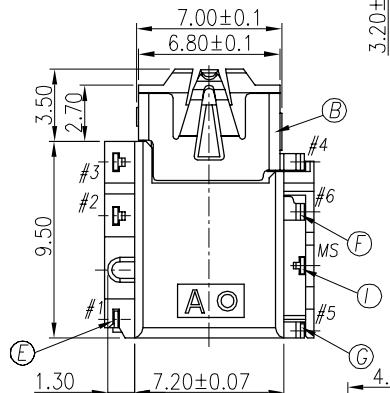
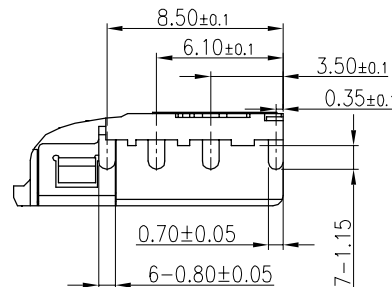
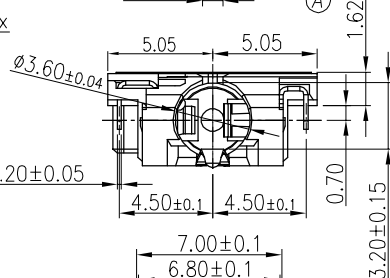

RECOMMENDED PLUG
Ø3.5 4-POLE STANDARD PLUG

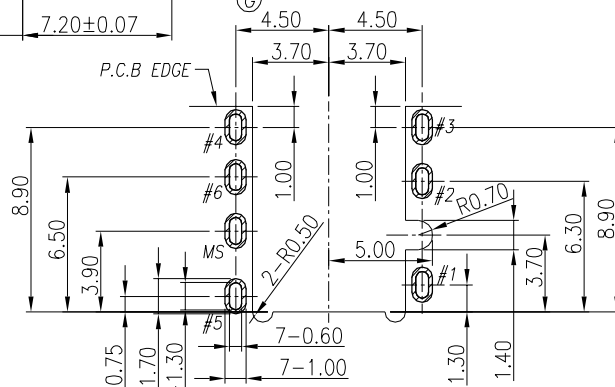

RECOMMENDED PCB LAYOUT

TOP VIEW ; TOL.±0.05

SPECIFICATIONS:

- INSULATION RESISTANCE BETWEEN ANY ADJACENT OPEN CIRCUIT TERMINAL SHELL NOT BE LESS THAN 100MΩ MEASURED BY 500 VDC.
- CONTACT RESISTANCE: 50mΩ MAX(INITIAL).
- INSULATION VOLTAGE WITHSTAND:500V AC FOR ONE MINUTE.
- UNLESS OTHERWISE SPECIFIED, TEST IS TO BE MADE AT 5-35°C IN TEMPERATURE AND 45-85% IN HUMIDITY. BUT,IF ANY VAGUE DATA IS OCCURED ON TEST RESULT, ANOTHER TEST SHALL BE MADE AT 20°C±2°C IN TEMP., 60-70% IN HUMIDITY.
- INSERTION FORCE: 0.4~4.0Kgf
- WITHDRAWAL FORCE:
INITIAL:1.0~4.0Kgf
AFTER LIFE TEST:0.4~4.0Kgf
- LIFE TEST: 5,000 CYCLES MIN.
- AFTER LIFE TEST, CONTACT RESISTANCE: 100mΩ MAX.
- AFTER HUMIDITY TEST, INSULATION RESISTANCE: 50MΩ MIN.
- MARKING: MARK "S" ON TOP OF CONNECTOR.
- PACKING : TAPE & REEL.
- TO CONFORM TO SINGATRON HAZARDOUS SUBSTANCE FREE SPEC.
- HALOGEN FREE PRODUCT IDENTIFICATION MARK ON PRODUCT:
- HALOGEN FREE PRODUCT IDENTIFICATION LOGO ON PACKAGING:

NO	DESCRIPTION	QTY	MATERIAL	PLATING & COLOR
J	MYLAR	1	KAPTON+SILICON GLUE,T=0.07	YELLOW
I	SHELL	1	SUS304-1/2H 0.2t	Ni 60u"Min.
H	SEPARATOR	1	LCP+30%GF,E130i,UL94V=0	BLACK
G	TRANSFER TERMINAL	1	C5210-EH 0.2t	GOLD FLASH ON CONTACT AREA; GOLD FLASH ON SOLDER AREA; ALL OVER 50u" Ni.
F	MAKE TERMINAL	1	C5210-EH 0.2t	GOLD FLASH ON CONTACT AREA; Molte Sn80u" ON SOLDER AREA; ALL OVER 50u" Ni.
E	TIP SPRING	1	SUS304-1/2H 0.2t	Au5u" ON CONTACT AREA; GOLD FLASH ON SOLDER AREA; ALL OVER 50u" Ni.
D	RING A	1	C5210-EH 0.2t	Au5u" ON CONTACT AREA;
C	RING B	1	C5210-EH 0.2t	Molte Sn80u" ON SOLDER AREA;
B	EARTH	1	C5210-EH 0.2t	ALL OVER 50u" Ni.
A	BODY	1	PA4T+30%GF,(TX1),UL94V=0	BLACK

UNLESS OTHERWISE SPECIFIED TOLERANCES

Singatron Enterprise Co., Ltd.
信音企業股份有限公司

DECIMALS:	ANGLES:	TITLE	3.5φ PHONE JACK		
X : ±0.5	X : ±2°	DWN	Ming	PART NO.2SJ3108-098111F	
X.X : ±0.3	X.X : ±1°	CHKD	Bruce	SCALE 4:1	UNIT: mm
X.XX : ±0.2		APVD	Lussen	SIZE: A3	SHEET:1 OF 1

CUSTOMER COPY