

REV.	ECN NO OR DESCRIPTION	REVISED	DATE
A	PDR NO: T161028-2A	ROBIN	2017.06.08

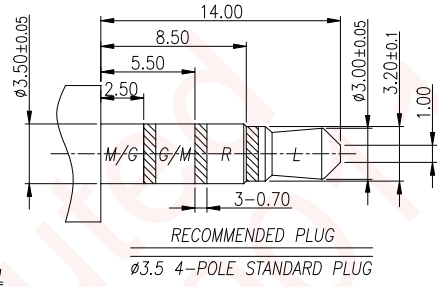

- SPECIFICATIONS:
- INSULATION RESISTANCE BETWEEN ANY ADJACENT OPEN CIRCUIT TERMINAL SHELL NOT BE LESS THAN 100MΩ MEASURED BY 500VDC .
 - CONTACT RESISTANCE: 50mΩ MAX(INITIAL).
 - INSULATION VOLTAGE WITHSTAND:500V AC FOR ONE MINUTE.
 - LIFE TEST: 5,000 CYCLES MIN.
 - INSERTION FORCE: 0.22-2.22Kgf ,
 - WITHDRAWAL FORCE: 0.22-2.22Kgf ,
 - AFTER TEST, CONTACT RESISTANCE: 100mΩ MAX.
 - AFTER HUMIDITY TEST, INSULATION RESISTANCE: 50MΩ MIN.
 - MARKING: MARK "S" ON TOP OF CONNECTOR.
 - PACKING : TAPE & REEL.
 - TO CONFORM TO SINGATRON HAZARDOUS SUBSTANCE FREE SPEC.
 - HALOGEN FREE PRODUCT IDENTIFICATION MARK ON PRODUCT:
 - HALOGEN FREE PRODUCT IDENTIFICATION LOGO ON PACKAGING:

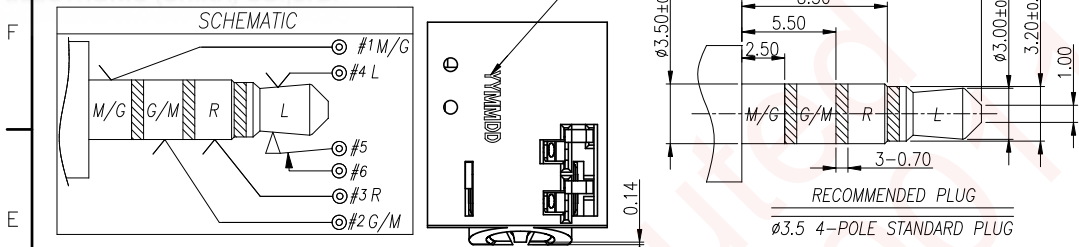
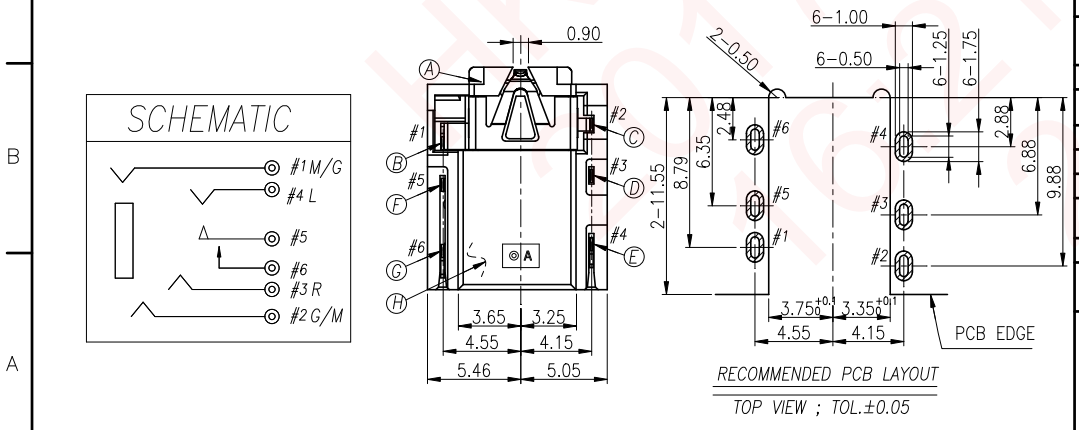
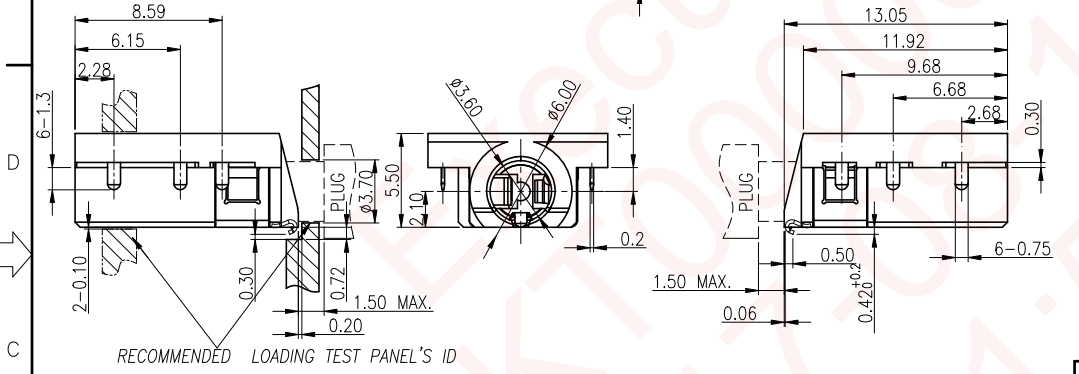

H	SEPARATOR	1	HIGH TEMP.THERMOPLASTIC UL 94V-0	BLACK
G	MAKE TERMINAL	1	PHOSPHOR BRONZE 0.2t	GOLD FLASH ON CONTACT AREA GOLD FLASH ON SOLDER AREA- ALL OVER 50μ" IN.
F	TRANSFER TERMINAL	1	PHOSPHOR BRONZE 0.2t	
E	TIP SPRING	1	SUS304-1/2H 0.2t	
D	RING A	1	PHOSPHOR BRONZE 0.2t	
C	RING B	1	PHOSPHOR BRONZE 0.2t	
B	EARTH	1	PHOSPHOR BRONZE 0.2t	
A	BODY	1	HIGH TEMP.THERMOPLASTIC UL 94V-0	BLACK
NO	DESCRIPTION	QTY	MATERIAL	PLATING & COLOR

UNLESS OTHERWISE SPECIFIED TOLERANCES		Singatron Enterprise Co., Ltd. 信音企業股份有限公司	
DECIMALS:	ANGLES:	TITLE: 3.5φ PHONE JACK	
X :±0.5	X :±2°	DWN	ROBIN PART NO. 2SJ3127-023111F
X.X :±0.3	X.X :±1°	CHKD	Bruce SCALE 4:1 UNIT: mm
X.XX :±0.2		APVD	Lussen SIZE: A3 SHEET:1 OF 1 REV: A
CUSTOMER COPY			