

REV.	ECN NO OR DESCRIPTION	REVISED	DATE
A	PDR NO: T220301-1A	Guorong	2022.08.25

DATE CODE:

MATCH MECHANISM ID NEEDS TO AVOID THE INTERFERENCE WITH TERMINAL AFTER PLUG IN.

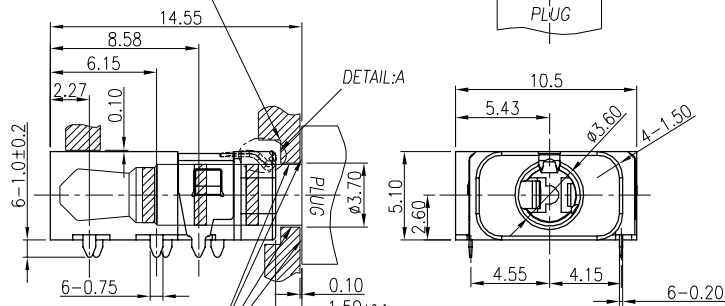

THE SURFACE OF MECHANISM ADJACENT TO PLUG SHALL BE INSULATED IF THE MECHANISM IS METAL.

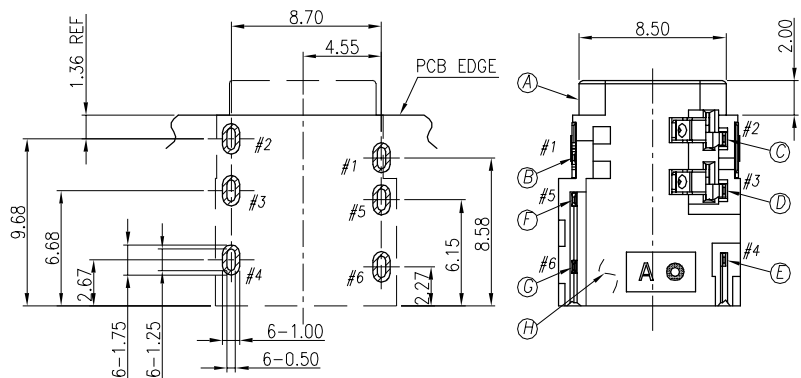

RECOMMENDED PCB LAYOUT
TOP VIEW ; TOL.±0.05

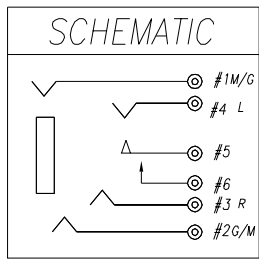
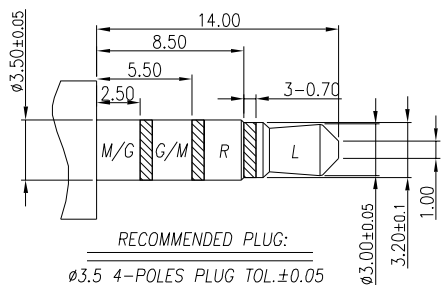
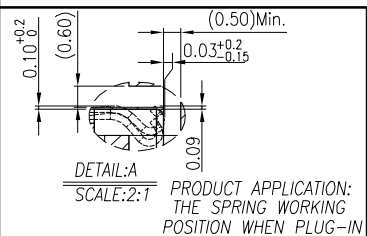

SPECIFICATIONS:

- ELECTRICAL CHARACTERISTICS:
 - RATING: 12V 1A
 - CONTACT RESISTANCE: 50mΩ MAX.(INITIAL)
 - DIELECTRIC WITHSTANDING VOLTAGE: 500V AC FOR ONE MINUTE.
 - INSULATION RESISTANCE: 100MΩ MIN. MEASURED BY 500 VDC.
- MECHANICAL CHARACTERISTICS:
 - INSERTION FORCE: 0.5~2.2Kgf AFTER THE FIFTH TIME;
0.4~2.2Kgf AFTER LIFE TEST;
 - WITHDRAWAL FORCE: 0.5~2.0Kgf AFTER THE FIFTH TIME;
0.4~2.0Kgf AFTER LIFE TEST;
- LIFE TEST: 5,000 CYCLES MIN.
AFTER LIFE TEST, CONTACT RESISTANCE: 100mΩ MAX.
- PACKAGING : TAPE & REEL.
- AFTER HUMIDITY TEST, INSULATION RESISTANCE: 50MΩ MIN.
- TO CONFORM TO SINGATRON HAZARDOUS SUBSTANCE FREE SPEC.
- HALOGEN FREE PRODUCT IDENTIFICATION MARK ON PRODUCT:
- HALOGEN FREE PRODUCT IDENTIFICATION LOGO ON PACKAGING:
- FOR LEAD-FREE PROCESS.
- PRINTED DATE CODE "YMD=" ON TOP OF CONNECTOR.

H	SEPARATOR	1	LCP+30%GF,UL94-V0	BLACK
G	MAKE TERMINAL	1	C5210-EH 0.2T	Au 1~3u" ON CONTACT AREA; Au 1~3u" ON SOLDER AREA; ALL OVER NICKEL 50u" MIN. PLATING
F	TRANSFER TERMINAL	1	C5210-EH 0.2T	
E	TIP SPRING	1	SUS304-1/2H,0.2T	
D	RING A	1	C5210-EH 0.2T	
C	RING B	1	C5210-EH 0.2T	
B	EARTH	1	C5210-EH 0.2T	
A	BODY	1	PA10T+30%GF, UL 94V-0	BLACK
NO	DESCRIPTION	QTY	MATERIAL	PLATING & COLOR

UNLESS OTHERWISE SPECIFIED TOLERANCES		Singatron Enterprise Co., Ltd. 信音企業股份有限公司	
DECIMALS:	ANGLES:	TITLE	3.5φ AUDIO JACK
X :±0.5	X :±2'	DWN	Guorong PART NO.2SJ3127-038111F
X.X :±0.3	X.X :±1'	CHKD	Bruce SCALE 1:1 UNIT: mm
X.XX :±0.2		APVD	Liao SIZE: A3 SHEET:1 OF 1 REV: A
CUSTOMER COPY			