

REV.	ECN NO.	OR DESCRIPTION	REVISED	DATE
A	PDR NO: T220321-4A	Carol	2022.11.20	

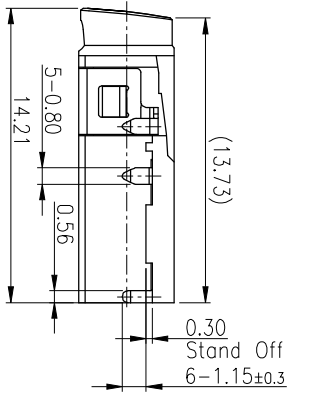

MATCHED MECHANISM'S ID NEED TO AVOID INTERFERENCE WITH TERMINAL AFTER PLUG IN

PICK&PLACE AREA
DATE CODE AREA(WMD)

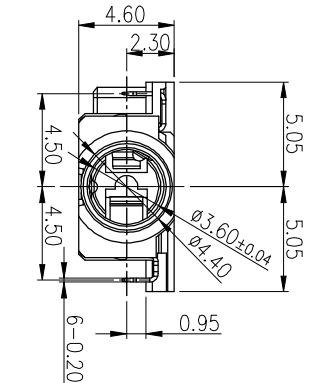
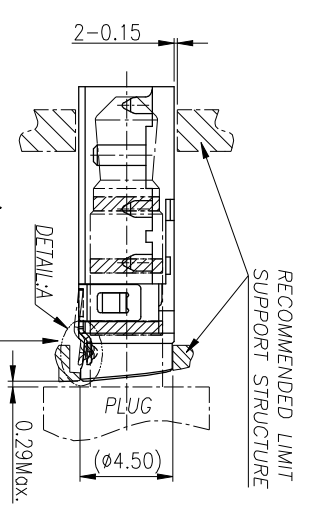
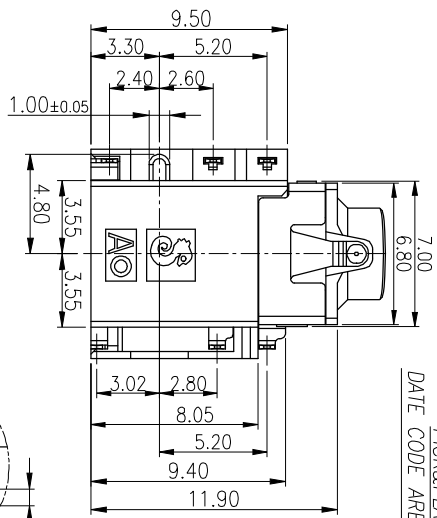
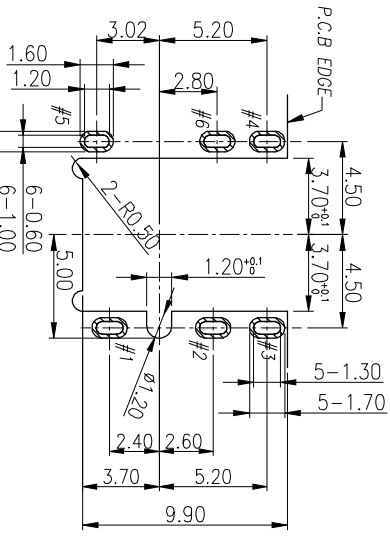

RECOMMENDED PCB LAYOUT
TOP VIEW ; TOL.±0.05

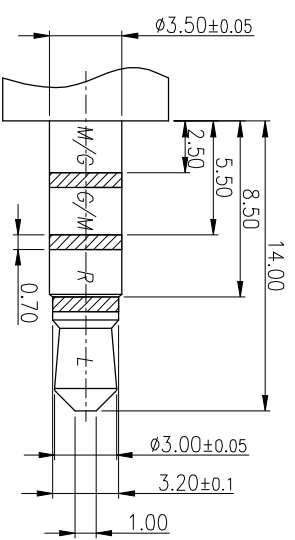
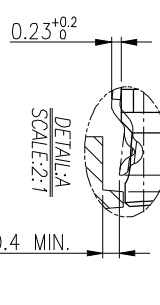

RECOMMENDED PLUG
Ø3.5 4-POLE PLUG

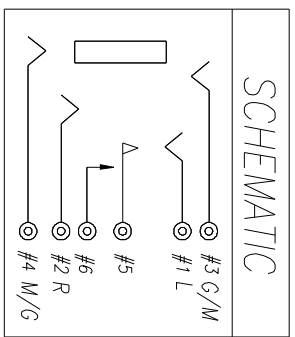

- SPECIFICATIONS:
- ELECTRICAL CHARACTERISTICS:
 - RATING: 12V 1A
 - CONTACT RESISTANCE: 50mΩ MAX.(INITIAL)
 - DIELECTRIC WITHSTANDING VOLTAGE: 500V AC FOR ONE MINUTE.
 - INSULATION RESISTANCE: 100MΩ MIN. MEASURED BY 500 VDC.
 - MECHANICAL CHARACTERISTICS:
 - INSERTION FORCE: 1.0-2.5kgf (AFTER 5 INSERTION CYCLES); 2.5kgf MAX. (AFTER LIFE TEST); 0.4kgf MIN. (AFTER LIFE TEST);
 - WITHDRAWAL FORCE: 0.6-1.8kgf (AFTER 5 INSERTION CYCLES); 0.4kgf MIN. (AFTER LIFE TEST);
 - LIFE TEST: 3,000 CYCLES MIN. AFTER LIFE TEST, CONTACT RESISTANCE: 50mΩ MAX.
 - PACKAGING: TAPE & REEL.
 - AFTER HUMIDITY TEST, INSULATION RESISTANCE: 50MΩ MIN.
 - TO CONFORM TO SINGATRON HAZARDOUS SUBSTANCE FREE SPEC.
 - HALOGEN FREE PRODUCT IDENTIFICATION MARK ON PRODUCT: (C)
 - HALOGEN FREE PRODUCT IDENTIFICATION LOGO ON PACKAGING: (R)
 - FOR REFLOW SOLDERING LEAD-FREE PROCESS.
 - PRINTED DATE CODE "WMD=" ON TOP OF JACK.

H	SEPARATOR	1	HIGH TEMPERATURE PLASTIC	UL94V-0	BLACK
G	TRANSFER TERMINAL	1	PHOSPHOR BRONZE 0.2T		COLD FLASH ON CONTACT AREA
F	MAKE TERMINAL	1	PHOSPHOR BRONZE 0.2T		COLD FLASH ON SOLDER AREA
E	TIP SPRING	1	STAINLESS STEEL 0.2T		ALL OVER 500° W.
D	RING A	1	PHOSPHOR BRONZE 0.2T		COLD FLASH ON CONTACT AREA
C	RING B	1	PHOSPHOR BRONZE 0.2T		COLD FLASH ON SOLDER AREA
B	EARTH	1	PHOSPHOR BRONZE 0.2T		ALL OVER 500° W.
A	BODY	1	HIGH TEMPERATURE PLASTIC	UL94V-0	BLACK
NO	DESCRIPTION	QTY	MATERIAL		PLATING & COLOR

UNLESS OTHERWISE SPECIFIED TOLERANCES

DECIMALS: ANGLES:

X :±0.5 X :±2°
X.X :±0.3 X.X :±1°
X.XX :±0.2

Singatron Enterprise Co., Ltd.
信登企業股份有限公司

Ø3.5 AUDIO JACK R/A TYPE

DWM Carol PART NO.2S13160-03S111F
CHKD Bruce SCALE 4:1 UNIT: mm
APVD Liao SIZE: A3 SHEET: 1 OF 1 REV: A

CUSTOMER COPY