



REV	ECN NO	OR DESCRIPTION	REVISED	DATE
A	PDR NO: T230524-5A	Qing	2023.10.25	

SPECIFICATIONS:

- ELECTRICAL CHARACTERISTICS:
 - RATING: 12V 1A
 - CONTACT RESISTANCE: 50mΩ MAX (INITIAL)
 - DIELECTRIC WITHSTANDING VOLTAGE: 500V AC FOR ONE MINUTE.
 - INSULATION RESISTANCE: 100MΩ MIN. MEASURED BY 500 VDC
- MECHANICAL CHARACTERISTICS:
 - INSERTION FORCE: 0.3 - 3.0kgf.
 - WITHDRAWAL FORCE: 0.3 - 3.0kgf.
- LIFE TEST: 3,000 CYCLES MIN.
- AFTER LIFE TEST, CONTACT RESISTANCE: 100mΩ MAX.
- AFTER HUMIDITY TEST, INSULATION RESISTANCE: 50MΩ MIN.
- TO CONFORM TO SINGATRON HAZARDOUS SUBSTANCE FREE SPEC.
- HALOGEN PRODUCT IDENTIFICATION MARK ON JACK: 
- HALOGEN PRODUCT IDENTIFICATION LABEL ON PACKAGING: 
- FOR REFLOW SOLDERING LEAD-FREE PROCESS.
- PRINTED DATE CODE "YMD-" ON TOP OF CONNECTOR.

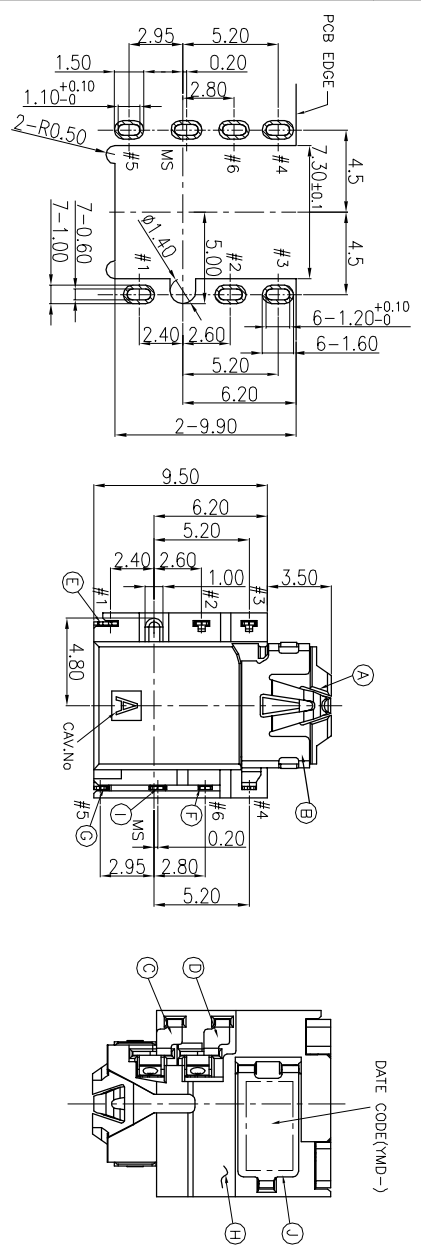
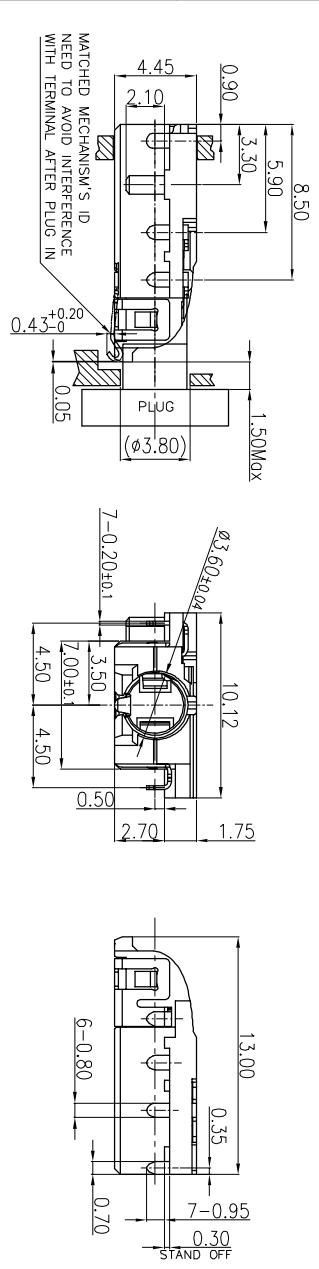

RECOMMENDED PCB LAYOUT(TOP VIEW)
TOP VIEW: TOL.±0.05

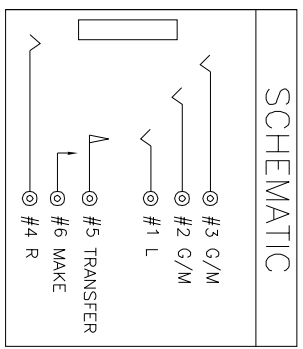

RECOMMENDED PLUG
Ø3.5 4-POLE STANDARD PLUG

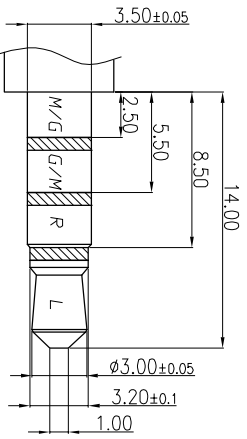

NO	DESCRIPTION	QTY	MATERIAL	PLATING & COLOR
J	SHELL	1	STAINLESS STEEL 0.2T	Ni 60u"Min
H	SEPARATOR	1	HIGH TEMP.THERMOPLASTIC UL 94V-0	BLACK
G	TRANSFER TERMINAL	1	PHOSPHOR BRONZE 0.2T	C/F ON CONTACT AREA AND SOLDER TAIL ALL OVER 50U"Min Ni
F	MAKE TERMINAL	1	PHOSPHOR BRONZE 0.2T	C/F ON CONTACT AREA AND SOLDER TAIL ALL OVER 50U"Min Ni
E	TIP	1	PHOSPHOR BRONZE 0.2T	
D	RING-A	1	PHOSPHOR BRONZE 0.2T	G/F ON CONTACT AREA MATTIe S80u" MIN. ON SOLDER TAIL ALL OVER 50U"Min Ni
C	RING-B	1	PHOSPHOR BRONZE 0.2T	
B	EARTH	1	PHOSPHOR BRONZE 0.2T	
A	HOUSING	1	HIGH TEMP.THERMOPLASTIC UL 94V-0	BLACK

UNLESS OTHERWISE SPECIFIED TOLERANCES

 Singatron Enterprise Co., Ltd.
信晉企業股份有限公司

DECIMALS:	ANGLES:
X :±0.5	X :±2°
X.X :±0.3	X.X :±1°
X.XX :±0.2	

TITLE	3.5Ø AUDIO JACK R/A TYPE
DWN Qing	PART NO.2S3J166-100111F
CHKD Bruce	SCALE 4:1 UNIT: mm
APVD Liao	SIZE: A3 SHEET: 1 OF 1 REV: A

CUSTOMER COPY