

DATE CODE AREA(M/D)

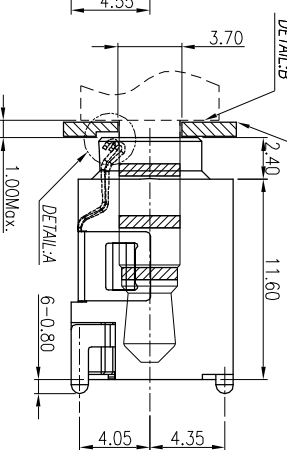

MATCHED MECHANISM'S ID NEED TO AVOID INTERFERENCE WITH TERMINAL AFTER PLUG IN

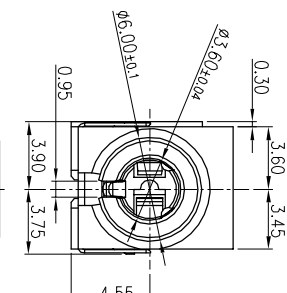
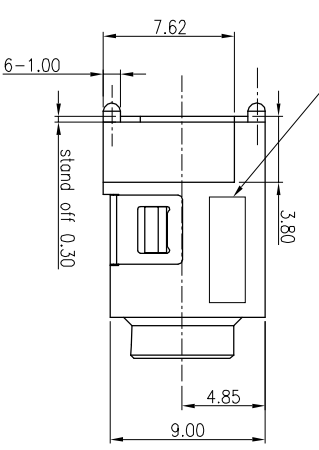
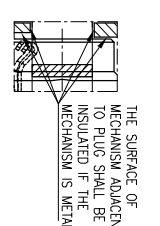
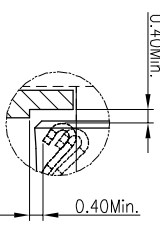

THE SURFACE OF MECHANISM ADJACENT TO PLUG SHALL BE INSULATED IF THE MECHANISM IS METAL.

- SPECIFICATIONS:
- ELECTRICAL CHARACTERISTICS:
 - RATING: 12V 1A
 - CONTACT RESISTANCE: 50mΩ MAX.(INITIAL)
 - DIELECTRIC WITHSTANDING VOLTAGE: 500V AC FOR ONE MINUTE.
 - INSULATION RESISTANCE: 100MΩ MIN. MEASURED BY 500 VDC.
 - MECHANICAL CHARACTERISTICS:
 - INSERTION FORCE: INITIAL 0.5-3.0kgf; 2-2. WITHDRAWAL FORCE: INITIAL 0.5-3.0kgf;
 - LIFE TEST: 5,000 CYCLES MIN.
 - AFTER LIFE TEST, CONTACT RESISTANCE: 100mΩ MAX.
 - PACKAGING : TAPE & REEL.
 - AFTER HUMIDITY TEST, INSULATION RESISTANCE: 50MΩ MIN.
 - TO CONFORM TO SINGATRON HAZARDOUS SUBSTANCE FREE SPEC.
 - HALOGEN FREE PRODUCT IDENTIFICATION MARK ON PRODUCT:
 - HALOGEN FREE PRODUCT IDENTIFICATION LOGO ON PACKAGING:
 - FOR REFLOW SOLDERING LEAD-FREE PROCESS.
 - PRINTED DATE CODE "MMDD" ON TOP OF CONNECTOR.

SCHMATIC

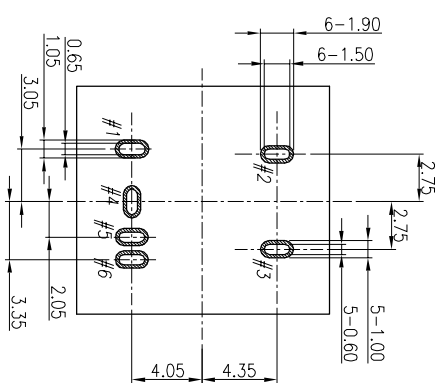
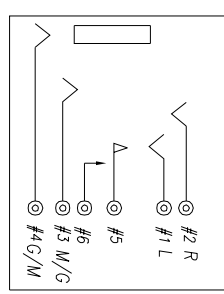

RECOMMENDED PCB LAYOUT
TOP VIEW : TOL.±0.05

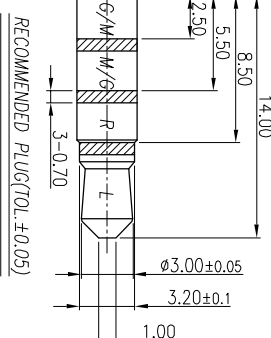
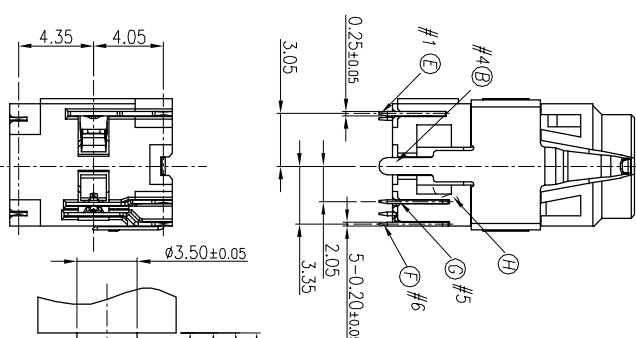

RECOMMENDED PLUG(TOL.±0.05)
Ø3.5 4-POLE PLUG

| NO | DESCRIPTION | QTY | MATERIAL | PLATING & COLOR |
|----|-------------------|-----|-------------------------------------|---------------------------|
| A | BODY | 1 | HIGH TEMP.THERMOPLASTIC UL 94V-0 | BLACK |
| B | EARTH | 1 | PHOSPHOR BRONZE 0.2t | ALL OVER 50μ Ni. |
| C | RING-A | 1 | PHOSPHOR BRONZE 0.2t | |
| D | RING-B | 1 | PHOSPHOR BRONZE 0.2t | |
| E | TIP SPRING | 1 | STAINLESS STEEL 0.25t | |
| F | MAKE TERMINAL | 1 | PHOSPHOR BRONZE 0.2t | ROD FLASH ON CONTACT AREA |
| G | TRANSFER TERMINAL | 1 | PHOSPHOR BRONZE 0.2t | ROD FLASH ON CONTACT AREA |
| H | SEPARATOR | 1 | HIGH TEMP.THERMOPLASTIC UL 94V-0 | BLACK |

Singatron Enterprise Co., Ltd.
信登企業股份有限公司

3.5Ø AUDIO JACK

| TITLE | PART NO. | UNIT | REV. |
|-------|----------|-----------------|------|
| DWM | Guorong | 25J3170-015111F | |
| CHKD | Bruce | SCALE 4:1 | |
| APVD | Lioo | SIZE: A3 | |

CUSTOMER COPY