

RECOMMENDED PCB LAYOUT (THICKNESS=0.8~1.6mm)
TOLERANCE FOR PCB LAYOUT: ±0.05 (TOP VIEW)

- NOTES:
1. MATERIAL:
 - 1.1 HOUSING/COVER/RING(A,B)/INSULATOR: PA9T w/ 27%GF, UL 94V-0; COLOR: BLACK
 - 1.2 TIP CONTACT(PIN#1M1/2M1): PBS, t=0.25±0.05mm
 - 1.3 CN CONTACT(PIN#1M4/2M4): PBS, t=0.25±0.05mm
 - 1.4 CN CONTACT(PIN#1M5/2M5): BRASS, t=0.20±0.05mm
 - 1.5 GND CONTACT(PIN#1M6/2M6): PBS, t=0.20±0.05mm
 - 1.6 BRIDGE: BRASS, t=0.50±0.05mm
 - 1.7 BRIDGE: BRASS, t=0.50±0.05mm
 - 1.8 FRONT SHIELD: SPC, t=0.30±0.05mm
 - 1.9 BACK SHIELD: SPC, t=0.30±0.05mm
 2. FINISH:
 - 2.1 BRIDGE/CONTACT(1M1/2M1/1M4/2M4/1M5/2M5): 2.54um[100u"] MIN. BRIGHT-TIN PLATING ON OVERALL.
 - 2.2 1M1/2M1 CONTACT: 1.27um[50u"] MIN. NICKEL UNDERPLATED OVERALL.
 - 2.3 FRONT SHIELD: 1.27um[50u"] MIN. NICKEL UNDERPLATED OVERALL.
 - 2.4 BACK SHIELD: 1.52um[60u"] MIN. COPPER UNDERPLATED OVERALL.
 - 2.5 2.54um[100u"] MIN. NICKEL PLATING ON OVERALL.
 3. WAVE SOLDER CAPABLE TO 265°C.
 4. NO PIN MARK ON THE PRODUCT.
 5. PER TE SPEC. 109-202 CONDUCT.
 5. LOW HALOGEN SPECIFICATION: CHLORINE(Cl): 900ppm MAX. BROMINE(Br): 900ppm MAX.

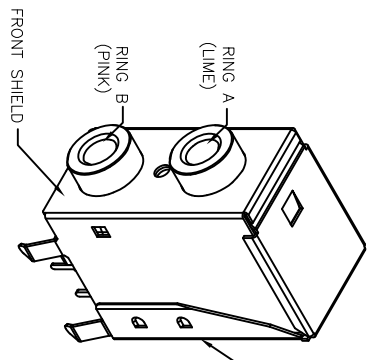

DIMENSIONS:		TOLERANCES UNLESS OTHERWISE SPECIFIED:	
	MM		
0	PLC	±	0.3
1	PLC	±	0.2
2	PLC	±	0.15
3	PLC	±	0.15
4	PLC	±	0.15
5	PLC	±	0.15
6	PLC	±	0.15
7	PLC	±	0.15
8	PLC	±	0.15
9	PLC	±	0.15
10	PLC	±	0.15
11	PLC	±	0.15
12	PLC	±	0.15
13	PLC	±	0.15
14	PLC	±	0.15
15	PLC	±	0.15
16	PLC	±	0.15
17	PLC	±	0.15
18	PLC	±	0.15
19	PLC	±	0.15
20	PLC	±	0.15
21	PLC	±	0.15
22	PLC	±	0.15
23	PLC	±	0.15
24	PLC	±	0.15
25	PLC	±	0.15
26	PLC	±	0.15
27	PLC	±	0.15
28	PLC	±	0.15
29	PLC	±	0.15
30	PLC	±	0.15
31	PLC	±	0.15
32	PLC	±	0.15
33	PLC	±	0.15
34	PLC	±	0.15
35	PLC	±	0.15
36	PLC	±	0.15
37	PLC	±	0.15
38	PLC	±	0.15
39	PLC	±	0.15
40	PLC	±	0.15
41	PLC	±	0.15
42	PLC	±	0.15
43	PLC	±	0.15
44	PLC	±	0.15
45	PLC	±	0.15
46	PLC	±	0.15
47	PLC	±	0.15
48	PLC	±	0.15
49	PLC	±	0.15
50	PLC	±	0.15

Singatron Enterprise Co., Ltd. 信音企業股份有限公司	
TITLE	Audio Jack H6.5mm(弯脚 PA9T)
DWN	ANDY 18Jun12
CHKD	PART NO. 2SJ343D-09DDBT-TBH
APVD	SCALE 1:1 UNIT: mm
	SIZE: A3 SHEET: 1 OF 2 REV: 1
CUSTOMER COPY	

DW		DESCRIPTION		DATE	DWN	APVD
P	LTR					
1		FIRST RELEASED		19Jun12	AW	WK

REV. NO.	DESCRIPTION	DATE	DWN	APVD
1	SEE SHEET 1			

- NOTES:
- PACKING MATERIAL TO BE MET THE SPEC TEC-138-702
 - CADMIUM AND CADMIUM COMPOUNDS CONTENT: 50ppm UNDER (PLASTIC, RUBBER, INK, PIGMENT, PAINT)
 - LEAD, CADMIUM, CHROM VI AND MERCURY CONTENT: 100ppm (COMBINED) UNDER. (IN PACKAGING MATERIAL)
 - EACH BAG SHALL BE INCLUDED:
 - * DESICCANT
 - MATERIAL:
 - 1.1 TRAY: PVC
 - 1.2 BAG: PE
 - INNER BOX: CORRUGATED FIBERBOARD
 - SHIPPING CARTON: CORRUGATED FIBERBOARD
4. DIMENSION:
- TRAY SIZE: 412mm*226mm
 - INNER BOX: L=422mm, W=238mm, H=114mm
 - SHIPPING CARTON: L=495mm, W=435mm, H=140mm
5. QUANTITY:
- PRIMARY PACKING: 100 PCS/TRAY
 - SECONDARY PACKING: 5 TRAYS/INNER BOX(500PCS)
 - THIRD PACKING: 2 INNER BOXES/CARTON(1,000PCS)
6. CARTON WEIGHT:
- NET WEIGHT: 10kg
 - GROSS WEIGHT: 11.5kg

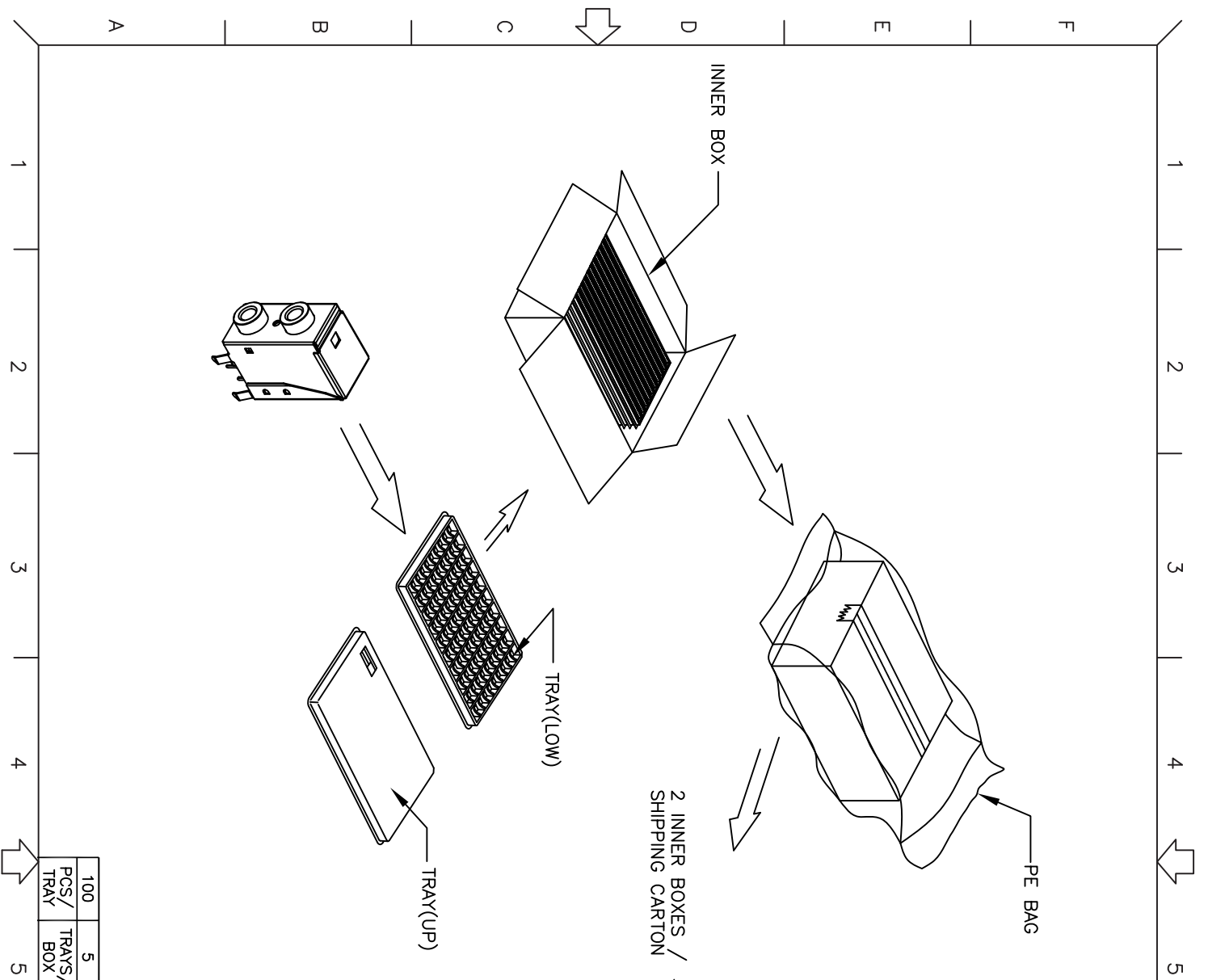

PCS/ TRAY	TRAYS/ BOX	BOXES/ CARTON	QUANTITY (PCS)	G/W (kg)	N/W (kg)
100	5	2	1000	11.5	10

 Singatron Enterprise Co., Ltd. 信音企業股份有限公司	
TITLE	Audio Jack H6.5mm(弯脚 PA9T)
DWN	ANDY 18AUN12
CHKD	PART NO. 2SJ343D-09DBT-TBH
APVD	SCALE 1:1 UNIT: mm
SIZE: A3 SHEET: 2 OF 2 REV: 1 CUSTOMER COPY	