

REV.	ECN NO OR DESCRIPTION	REVISED	DATE
A	PDR NO:T130513-7A	Danfeng	2015.04.29

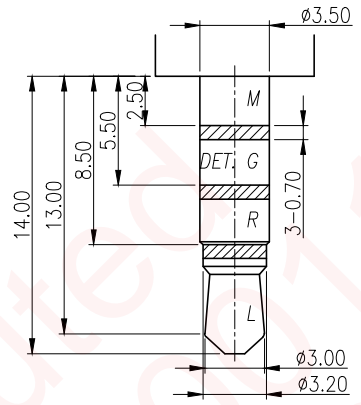

RECOMMENDED PLUG(Tol:±0.05)  
Ø3.5 4-POLE PLUG

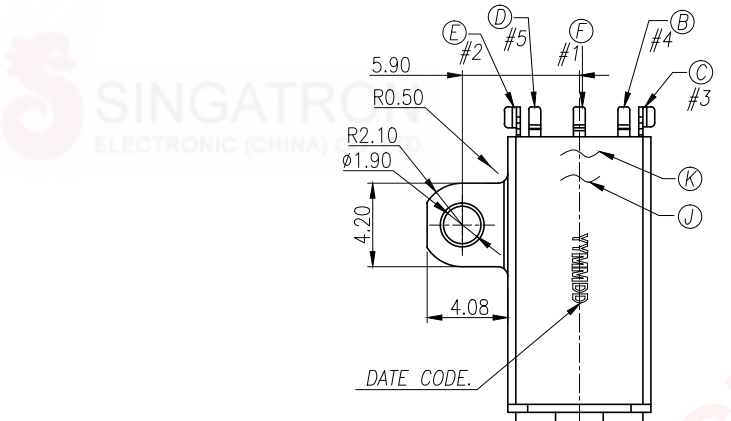
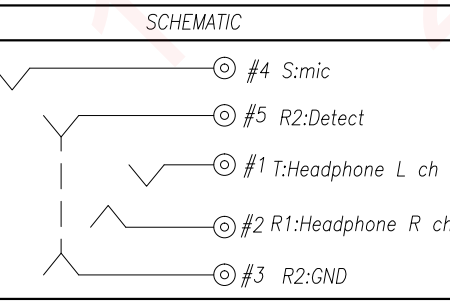
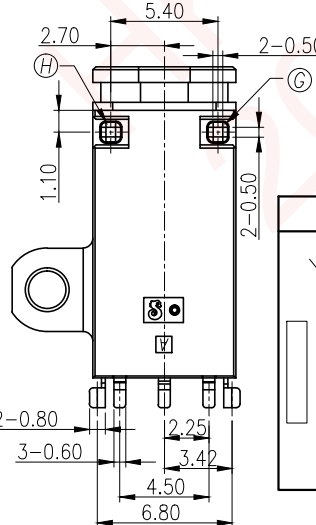
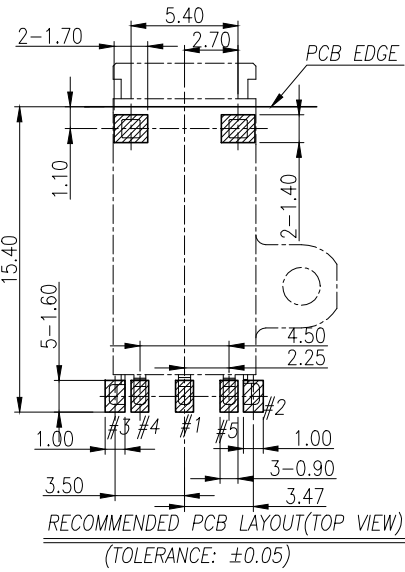
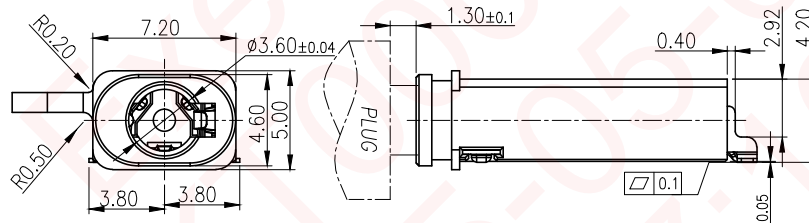
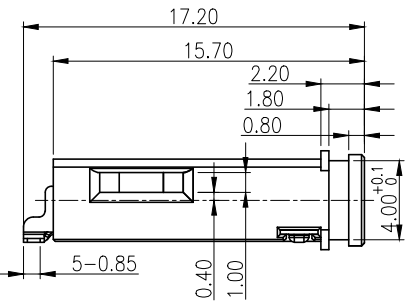

- SPECIFICATIONS:
- ELECTRICAL CHARACTERISTICS:
    - 1-1. RATING: 12V 1A
    - 1-2. CONTACT RESISTANCE: 50mΩ MAX.(INITIAL) 100mΩ MAX.(AFTER)
    - 1-3. DIELECTRIC WITHSTANDING VOLTAGE: 500V AC FOR ONE MINUTE.
    - 1-4. INSULATION RESISTANCE: 100MΩ MIN. MEASURED BY 500 VDC
  - MECHANICAL CHARACTERISTICS:
    - 2-1. INSERTION FORCE : 0.3~3.0 KGF
    - 2-2. WITHDRAWAL FORCE : 0.3~3.0 KGF
  - LIFE TEST: 10,000 CYCLES MIN.
    - 2-1. INSERTION FORCE : 0.3~3.0 KGF
    - 2-2. WITHDRAWAL FORCE : 0.3~3.0 KGF
  - WATRPROOF RATE: IP65 IP67
    - 4-1. IP65: PROTECTED AGAINST LOW PRESSURE JETS OF WATER
    - 4-2. IP67: IMMERSED IN 1M WATER FOR 30 MINUTES
  - OTHER GENERAL SPEC. TO REFER "2SJ3W01-000111F SERIES SPEC".
  - HALOGEN FREE PRODUCT IDENTIFICATION MARK ON PRODUCT: (circled symbol)
  - HALOGEN FREE PRODUCT IDENTIFICATION LOGO ON PACKAGING: (logo symbol)
  - FOR REFLOW SOLDERING LEAD-FREE PROCESS.

K	GLUE	1		
J	COVER	1	HIGH TEMP.THERMOPLASTIC UL 94V-0	BLACK
H	SHUNT TERMINAL-L	1	BRASS 0.2t	MATTE SN 120u" ALL OVER NI 50u" PLATING.
G	SHUNT TERMINAL-R	1	BRASS 0.2t	
F	TIP SPRING	1	PHOSPHOR BRONZE 0.2T	GOLD FLASH ON CONTACT AREA;
E	RING-A	1	PHOSPHOR BRONZE 0.2T	MATTE SN 120u" ON SOLDER TAIL AREA;ALL OVER NI 50u" PLATING.
D	RING-B-L	1	PHOSPHOR BRONZE 0.2T	
C	RING-B-R	1	PHOSPHOR BRONZE 0.2T	
B	EARTH	1	PHOSPHOR BRONZE 0.2T	
A	BODY	1	PA4T+30% GF UL94-V0 (Tx1)	BLACK
NO	DESCRIPTION	QTY	MATERIAL	PLATING & COLOR

UNLESS OTHERWISE SPECIFIED TOLERANCES

DECIMALS: ANGLES:

X :±0.5 X :±2°

X.X :±0.3 X.X :±1°

X.XX :±0.2

SINGATRON ENTERPRISE CO., LTD. 信音企業股份有限公司		<b>Ø3.50 AUDIO JACK</b>	
TITLE	<b>Ø3.50 AUDIO JACK</b>		
DWN Danfeng	<b>PART NO.2SJ3W01-000111F</b>		
CHKD Bruce	SCALE 1:1	UNIT: mm	④
APVD Lussen	SIZE: A3	SHEET:1 OF 1	<b>REV: A</b>
<b>CUSTOMER COPY</b>			