

REV.	ECN NO OR DESCRIPTION	REVISED	DATE
A	PDR RELEASE	AMYC	2008.11.26
B	ECN NO. L090037	AMYC	2009.07.06

**SPECIFICATIONS:**

1. OTHER GENERAL SPEC. TO REFER "2SM1501 SERIES SPEC".
2. TO CONFORM TO SINGATRON HAZARDOUS SUBSTANCE FREE SPEC.
3. GREEN PRODUCT IDENTIFICATION LABEL ON PACKAGING: **G.P. PASS**
4. PACKAGE : SEE "2SM1501 SERIES" PACKAGE

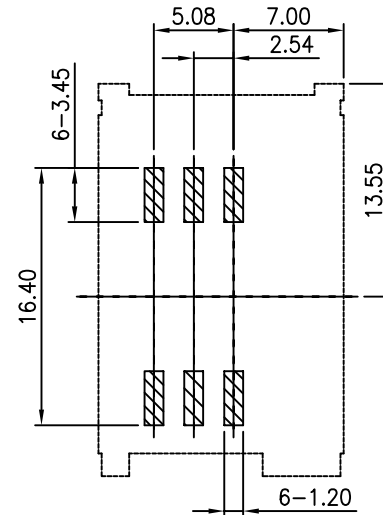
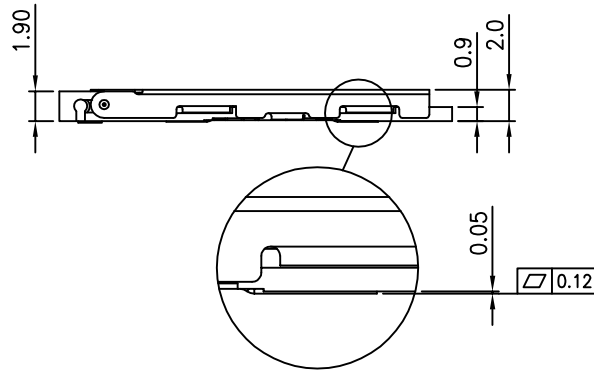
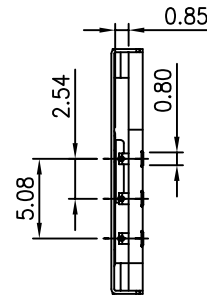
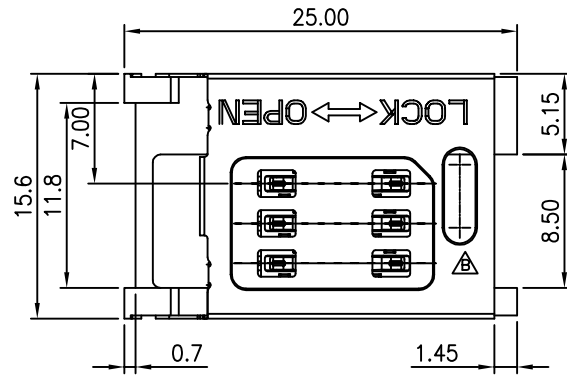

**Recommend PCB Layout  
Tolerance: ±0.05mm (Top view)**

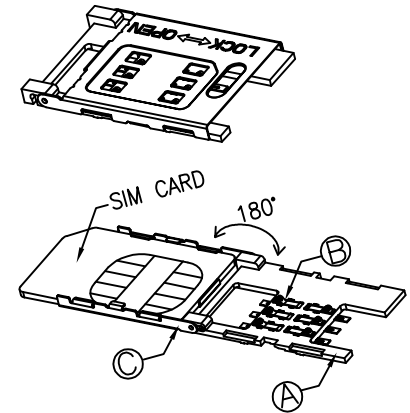

- 2SM1501-000111
- PACKAGE: 1: TAPE & REEL
  - HOUSING COLOR: 1: BLACK
  - CONTACT PLATING: 1: Au PLATING

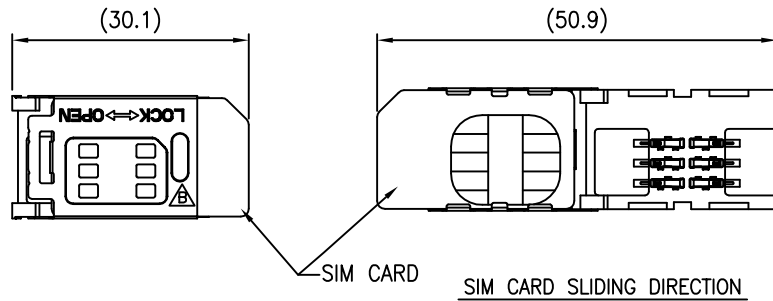

NO	DESCRIPTION	QTY	MATERIAL	PLATING & COLOR
C	COVER	1	STAINLESS STEEL (SUS304)	
B	CONTACT	6	PHOSPHOR BRONZE STRIP	Au PLATING
A	HOUSING	1	HIGH TEMP (LCP)	BLACK COLOR
UNLESS OTHERWISE SPECIFIED TOLERANCES				
DECIMALS:			ANGLES:	TITLE
X	:±0.5	X	:±2°	DWN
X.X	:±0.3	X.X	:±1°	CHKD
X.XX	:±0.2			APVD
SINGATRON ENTERPRISE CO., LTD. 信音企業股份有限公司			SIM CARD HINGED	
PART NO. 2SM1501-000111			SCALE: N/A	
UNIT: mm			SHEET: 1 OF 1	
SIZE: A3			REV: B	
<b>CUSTOMER COPY</b>				