

REV.	ECN NO OR DESCRIPTION	REVISED	DATE
A	PRODUCT RELEASE	BILL	2016/06/24

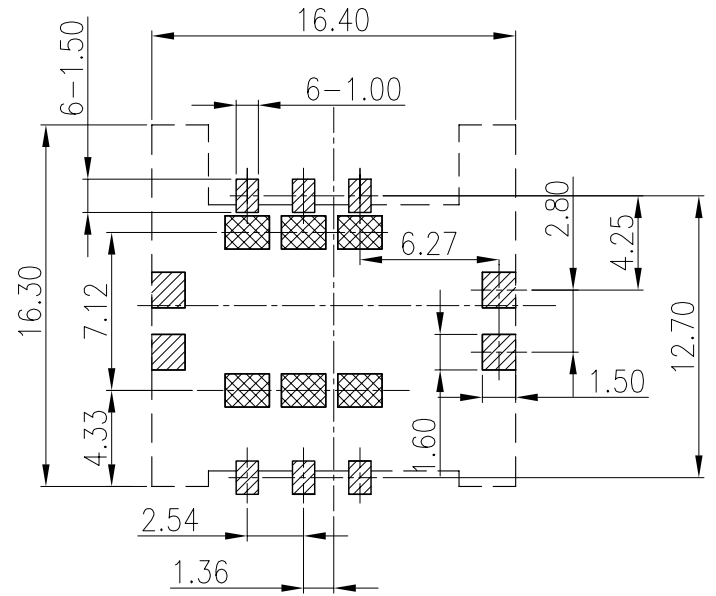

THIS AREA SHOULD BE FREE OF ANY CONDUCTIVE TRACES
 SMT SOLDER AREA
P.C.B. LAYOUT(TOP VIEW)
 TOLERANCE:±0.05

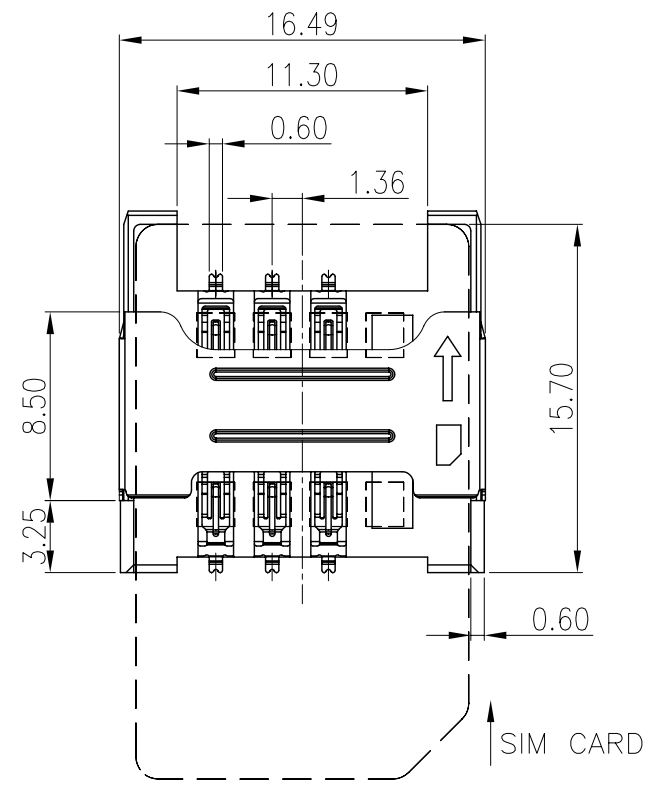
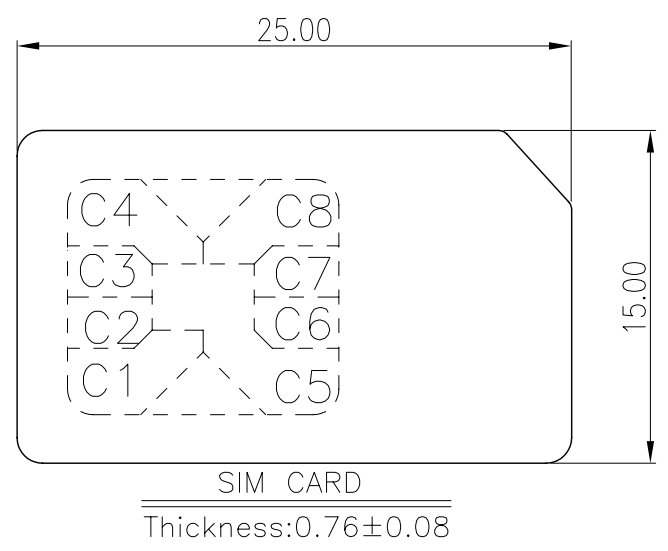
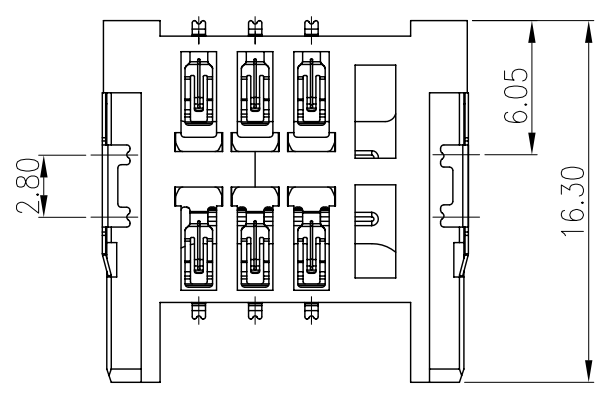
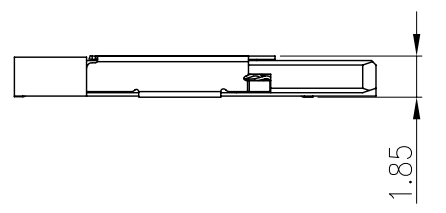
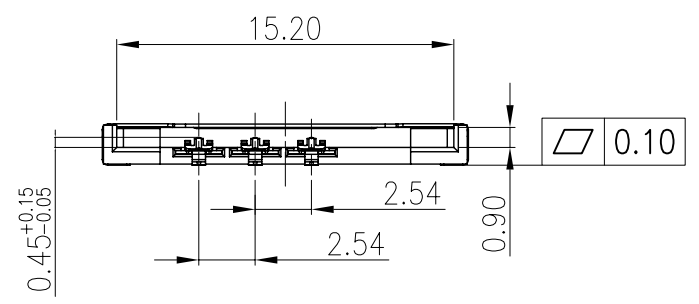

- SPECIFICATIONS:
- CURRENT RATING:1A
 - VOLTAGE RATING:50V
 - CONTACT RESISTANCE: 30mΩ (INITIAL), 50mΩ (AFTER LIFE TEST) .
 - WITHSTANDING VOLTAGE: 100V AC FOR 1 MINUTE.
 - INSULATION RESISTANCE: 100MΩ MIN. BY 100V DC .
 - LIFE TEST: 1,500 CYCLES .
 - TO CONFORM TO SINGATRON HAZARDOUS SUBSTANCE FREE SPEC.
 - HALOGEN FREE PRODUCT IDENTIFICATION MARK ON PRODUCT:
 - HALOGEN FREE PRODUCT IDENTIFICATION LABEL ON PACKAGING:
 - FOR REFLOW SOLDERING LEAD-FREE PROCESS.
 - PACKAGING:TAPE & REEL.

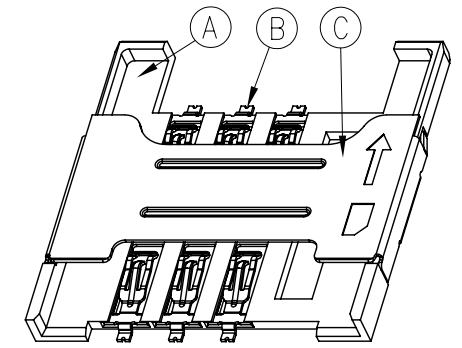

PIN NO.	PIN NAME
C1	Supply voltage Vcc
C2	Reset (RST)
C3	Clock (CLK)
C5	Ground
C6	Programming voltage vpp
C7	I/O
C4/C8	NONE

NO	DESCRIPTION	QTY	MATERIAL	PLATING & COLOR
C	SHELL	1	STAINLESS STEEL	GOLD PLATING ON SOLDER AREA ALL OVER NICKEL 50u" MIN. PLATING
B	CONTACT	6	COPPER ALLOY	GOLD FLASH ON CONTACT AREA MATTE SN ON SOLDER TAIL ALL OVER NICKEL 50u" MIN. PLATING
A	HOUSING	1	HIGH TEMP. THERMOPLASTIC UL 94V-0	BLACK

UNLESS OTHERWISE SPECIFIED TOLERANCES		Singatron Enterprise Co., Ltd. 信音企業股份有限公司		
DECIMALS:	ANGLES:	TITLE	SIM CARD H=1.85	
X :±0.5	X :±2°	DWN	Bill-Zhang 16/06/30	PART NO. 2SM2Y26-000111F
X.X :±0.3	X.X :±1°	CHKD	Justin-Kuo 16/06/30	SCALE 3:1 UNIT: mm
X.XX :±0.2		APVD	Max-Mai 16/06/30	SIZE: A3 SHEET:1 OF 1 REV: A
CUSTOMER COPY				