

REV.	ECN NO.	OR DESCRIPTION	REVISED	DATE
A	PDR NO: 20070620-1-S		BOYE.QI	2007.10.11
B	ECN NO: S071021		BOYE.QI	2007.11.26
C	ECN NO: S071102		BOYE.QI	2008.02.01
D	ECN NO: S080130		BOYE.QI	2008.02.01
D	ECN NO: T080204		LJI	2008.12.10

- NOTES:
- ELECTRICAL PERFORMANCES:
 - CURRENT RATING: 0.50 A MAX.
 - CONTACT RESISTANCE: 50 mΩ MAX.
 - INSULATION RESISTANCE: 100 MΩ MIN.
 - Dielectric WITHSTANDING VOLTAGE: 250V AC FOR 1 MINUTE.
 - MECHANICAL PERFORMANCES:
 - CONTACT NORMAL FORCE: 0.30N MIN. AT DEFLECTION.
 - MECHANICAL OPERATION: 5000 CYCLES.
 - OPERATING TEMPERATURE: -40°C TO 85°C
 - HALOGEN FREE PRODUCT IDENTIFICATION MARK ON PRODUCT:
 - HALOGEN FREE PRODUCT IDENTIFICATION LOGO ON PACKING:
 - FOR LEAD-FREE PRODUCT.
 - SOLDERING HEAT RESISTANCE: 260°C 10 SEC.
 - PRINTED DATE CODE "YMMDD" ON TOP OF CONNECTOR.



PART NO:

PARD NO.	DIM. H
2SM3013-002111	1.80
2SM3023-002111	2.00
2SM3033-002111	2.20

NO	DESCRIPTION	QTY	MATERIAL	PLATING & COLOR
C	COVER	1	STAINLESS STEEL,T=0.12	Gold flash Over Ni50u"
B	CONTACT	6	PHOSPHOR BRONZE,T=0.12	Au on Contact Area. Gold flash on other area. Over Nickel plating.
A	BODY	1	HIGH TEMP:U194V-0	BLACK

UNLESS OTHERWISE SPECIFIED TOLERANCES

DECIMALS:	ANGLES:
X :±0.5	X :±2'
X.X :±0.3	X.X :±1'
X.XX :±0.2	

TITLE	SIM CARD CONN.
DWN U 2008.12.10	PART NO. 2SM3033-002111
CHKD Less:2008.12.10	SCALE:4:1
APVD U 2008.12.10	SIZE: A3
	SHEET: 1 OF 2
	REV: D

Singatron Enterprise Co., Ltd.
信譽企業股份有限公司

CUSTOMER COPY

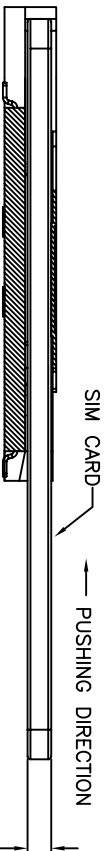
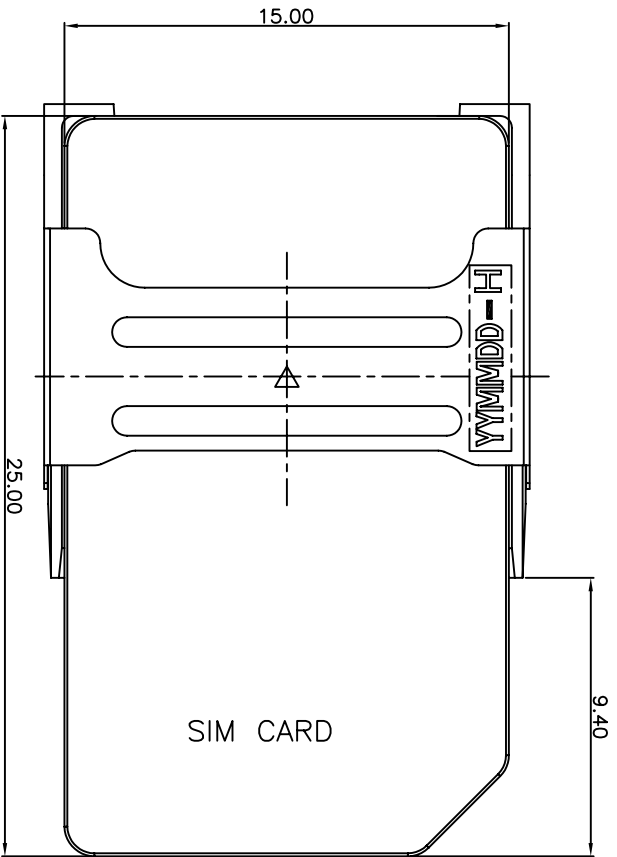
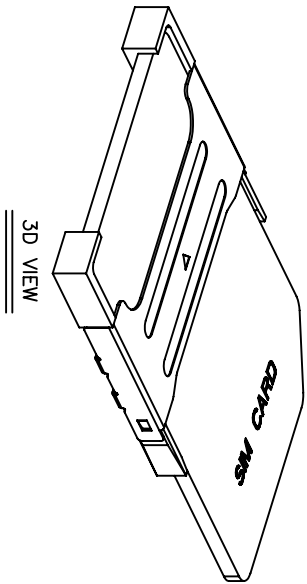

REV.	ECN NO.	OR DESCRIPTION	REVISED	DATE
A	PDR NO: 20070620-1-S		BOYE.QI	2007.10.11
B	ECN NO: S071021		BOYE.QI	2007.11.26
C	ECN NO: S071102		BOYE.QI	2008.02.01
C	ECN NO: S080130		BOYE.QI	2008.02.01
D	ECN NO: T080204		Lili	2008.12.10

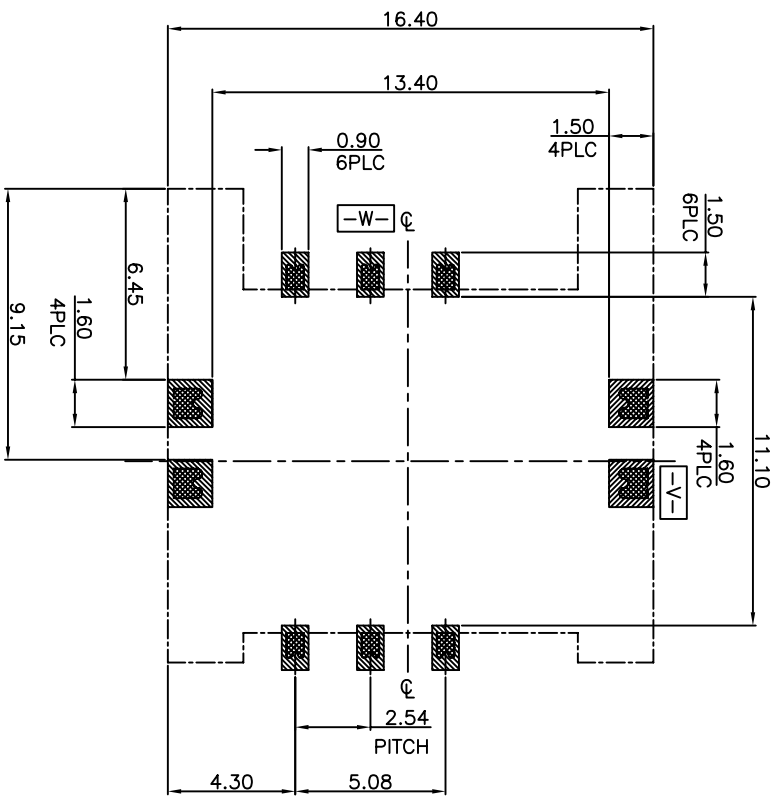

RECOMMENDED P.C.B LAYOUT(TOP VIEW)
TOLERANCE ±0.05mm

NO	DESCRIPTION	QTY	MATERIAL	PLATING & COLOR
UNLESS OTHERWISE SPECIFIED TOLERANCES				
DECIMALS:	ANGLES:			
X :±0.5	X :±2°			
X.X :±0.3	X.X :±1°			
X.XX :±0.2				
TITLE	SIM CARD CONN.			
DWN	2008.12.10	PART NO.	2SM30□3-002111	
CHKD	2008.12.10	SCALE:	4:1	UNIT: mm
APVD	2008.12.10	SIZE:	A3	SHEET: 2 OF 2 REV: D

Singatron Enterprise Co., Ltd.
信晉企業股份有限公司

CUSTOMER COPY