

Rev.	Description	Date	Drawn	Checked

MATERIALS
 HOUSING: LCP HI-TEMP. PLASTIC (UL 94V-0), BLACK
 SHELL: STAINLESS STEEL, NICKEL PLATED
 TERMINAL: PHOSPHOR BRONZE, GOLD PLATED

SPECIFICATION
 CURRENT RATING: 0.5 AMP MAX
 DIELECTRIC WITHSTANDING: 500V AC FOR ONE MINUTE
 CONTACT RESISTANCE: 30m OHMS MAX
 INSULATION RESISTANCE: 1000M OHMS MIN AT DC 500V
 OPERATION TEMPERATURE: -25°C~+85°C

Packing: (Tape & Reel)
 1 Reel = 1000 Pcs

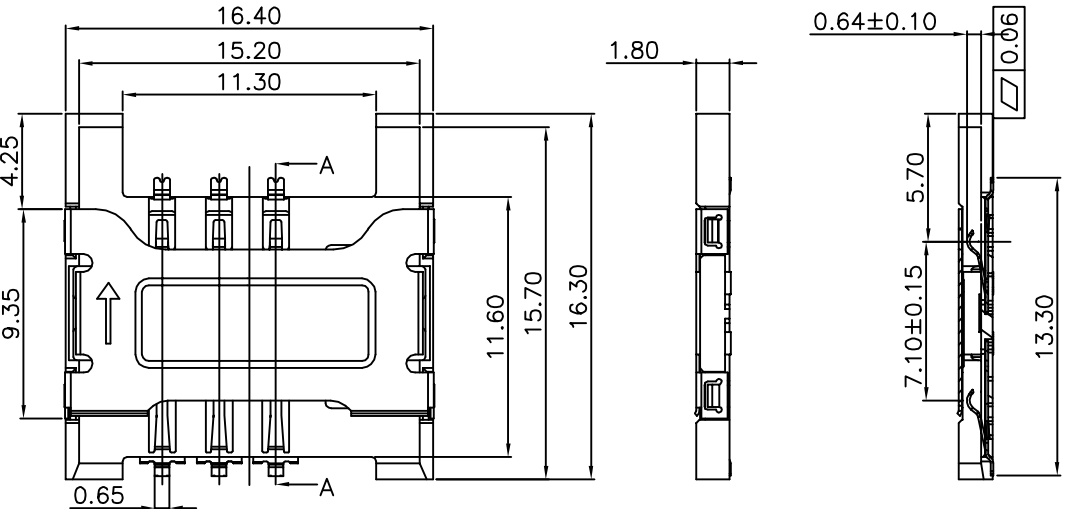

A-A SECTION

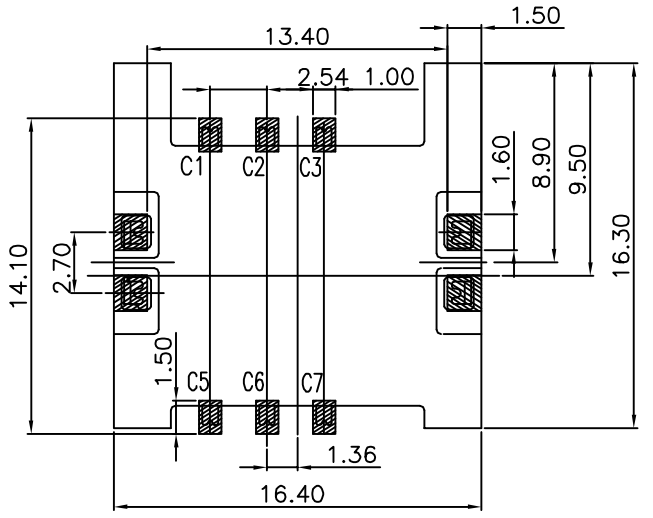

P.C.B LAYOUT
 TOP VIEW ±0.05

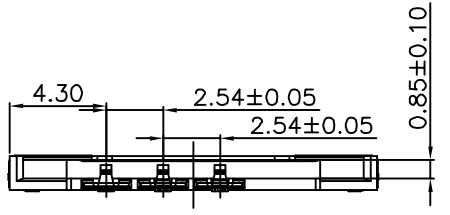

PART NUMBER
2SM40GBH - 0 6 * - 1 2 K L

SERIES — NO. OF POS. — CONTACT PLATED OPTION — LEAD FREE — PACKAGE OPTION

1: GOLD FLASH
 4: 15u" GOLD
 6: 30u" GOLD

2: TAPE REEL

TABLE A:

PIN NO.	PIN NAME
C1	Supply Voltage Vcc
C2	Reset (RST)
C3	Clock(CLK)
C4	N/A
C5	Ground
C6	Programming Voltage Vpp

GENERAL TOLERANCE :
 .X ±0.30 Ang. ±3°
 .XX ±0.20
 .XXX ±0.10

Singatron Enterprise Co., Ltd.			
TITLE	SIM CARD, 6PIN, PCB MOUNT, SMT, FEMALE,		
DWN	SHC	PART NO. 2SM40GBH - 0 6 * - 1 2 K L	
CHKD	SCALE 1:1		UNIT: mm
APVD	SIZE: A3	SHEET: 1 OF 1	REV: A
CUSTOMER COPY			