

NOTE:

1.MATERIAL:

- A. HOUSING: LCP, UL 94-V0 COLOR: BLACK.
- B. CONTACT: PHOSPHOR BRONZE T=0.12mm
- C. SHELL: SUS 304 1/2H T=0.15mm

2. PLATING:

- Underplate: 50~80u" Nickel
- Contact area: 3~30u" Gold
- Solder tails area: 3u" Gold
- Shell: 50~80u" Nickel

3.ELECTRICAL CHARACTERISTICS:

- A. Operating voltage: 30V(AC/DC).
- B. Current rating: 1AMP MAX
- C. Operating temperature: -20°c~+85°c.
- D. Insulation resistance: 1000M ohme min. at 200VDC.
- E. Dielectric withstanding voltage: 500 VAC/1minute.
- F. Contact resistance: 30m ohme max.

4. MECHANICAL CHARACTERISTICS:

- A Durabilty: 1500cycles
- B Opetating force(inserting & withrwal) : 1N~10N

5.PACKAGE: TAPE REEL, 1000PCS/REEL

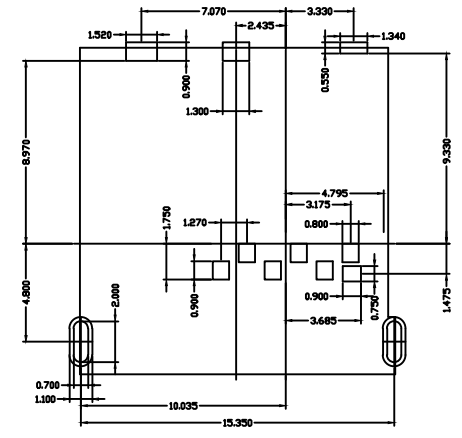
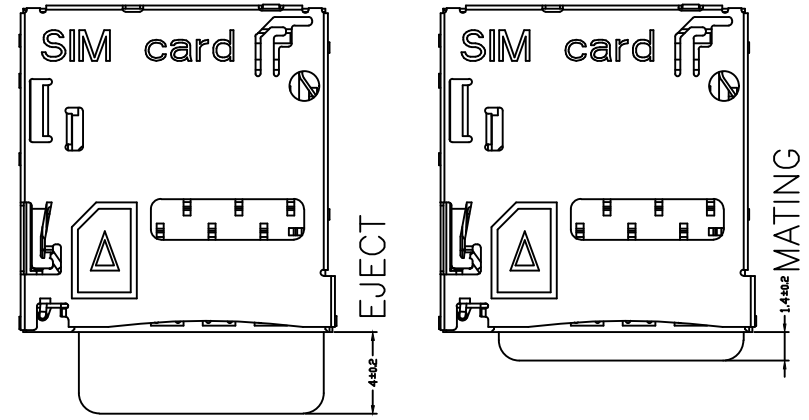

RECOMMENDED PCB LAYOUT
TOL:(±0.05)

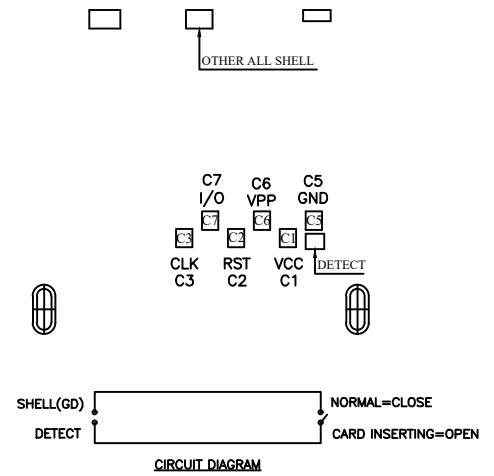

Singatron Enterprise Co., Ltd.

GENERAL TOLERANCE		TITLE	Micro SIM Conn. Standard Push Type H:1.80		
XX. ±	XXX. ±	DWN	FGVEN 2014/01/15	PART NO. 2SM6401-ST018001G0-1S	
X. ± 0.30	.XXX ± 0.05	CHKD	CHARLES	SCALE 1:1	UNIT: mm
.X ± 0.25	X.* ± 3'	APVD	JAMES	SIZE: A3	SHEET: 1/2
.XX ± 0.20	.X* ± 2'	CUSTOMER COPY			
				REV: 1	

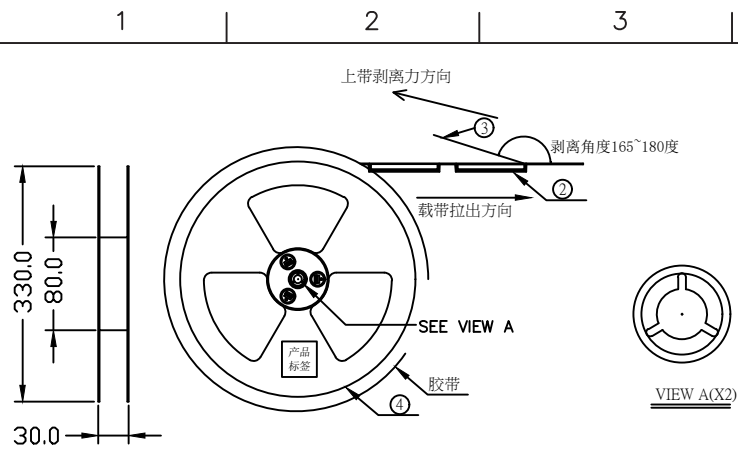

前端卷入空下带500mm(25格) 中间包装产品1000PCS 尾端卷入空下带100mm(5格)

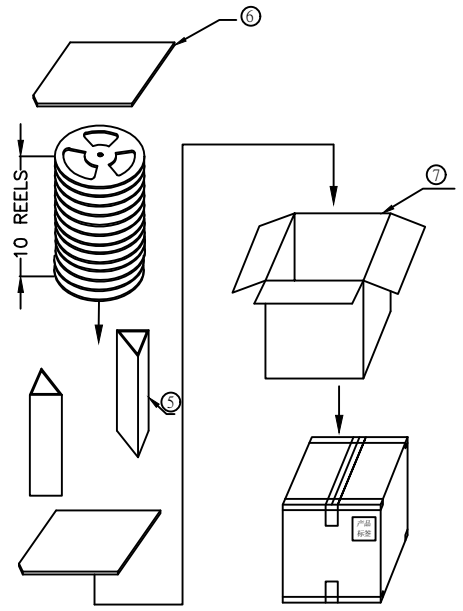
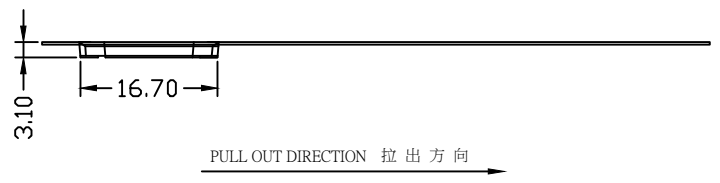
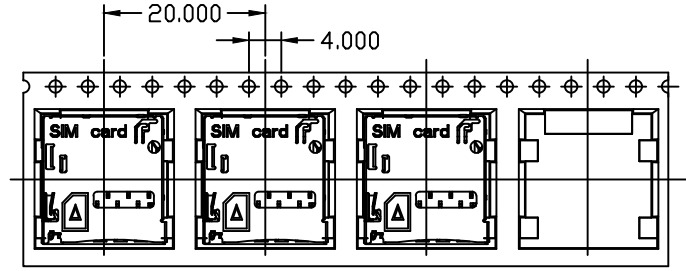

PACKING NOTES:

1. PRIMARY PACKING: 1300PCS/REEL;
2. SECONDARY PACKING: 10 REELS/CARTON (13KPCS/CARTON)
3. PEELING RESISTANCE: 30gf~100gf
4. PEELING ANGLE: 165°~180°
5. PEELING SPEED: 300mm/minutes.

TABLE:

NO.	NAME	SPEC.	REMARK
①	成品	PUSH MICRO SIM CARD 1.8H	1000PCS/R
②	下带(载带)	PET料 透明色,W=24mm,P=20mm,T=0.3mm.	20.6M/1000PCS
③	上带(盖带)	W=21.3mm,T=0.06mm,自粘式透明状	20.8M/1000PCS
④	REEL(蓝色卷盘)	外直径330mm,内直径100mm,内宽44.5mm	1PCS/1000PCS
⑤	折叠板	296*464*6mm	4PCS/10000PCS
⑥	平板	328*328*6mm	2PCS/10000PCS
⑦	CARTON (外箱)	350*350*335mm	1PCS/10000PCS

Singatron Enterprise Co., Ltd.

GENERAL TOLERANCE		TITLE	Micro SIM Conn. Standard Push Type H:1.80		
XX. ±	XXX. ±	DWN	FGVEN 2014/01/15	PART NO. 2SM6401-ST018001G0-1S	
X. ± 0.30	.XXX ± 0.05	CHKD	CHARLES	SCALE 1:1	UNIT: mm
.X ± 0.25	X.* ± 3'	APVD	JAMES	SIZE: A3	SHEET: 2/2
.XX ± 0.20	.X.* ± 2'	CUSTOMER COPY			