

| REV. | ECN NO OR DESCRIPTION | REVISED | DATE |
|------|-----------------------|---------|------------|
| A | PDR RELEASE | IY-C | 2012.02.23 |

SPECIFICATIONS:

- ELECTRICAL CHARACTERISTICS:
 - CURRENT RATING: 1.5 AMP. MAX.
 - CONTACT RESISTANCE: 30mΩ MAX.
 - INSULATION RESISTANCE: 1000MΩ MIN. @ 500V AC.
 - DIELECTRIC WITHSTANDING VOLTAGE: 500V AC FOR 1 MINUTE.
- MECHANICAL CHARACTERISTICS:
 - INSERTION FORCE: 45N MAX.
 - LIFE TEST: 500 CYCLES.
- OTHER GENERAL SPEC. TO REFER "2ST1522 SERIES SPEC".
- TO CONFORM TO THE SINGATRON HAZARDOUS SUBSTANCE FREE SPEC.
- HALOGEN FREE PRODUCT IDENTIFICATION LABEL ON PACKAGING.
- PACKAGE: SEE "2ST1523 SERIES" PACKAGE.
- FOR REFLOW SOLDERING LEAD-FREE PROCESS.

PART NO.

2ST1523-000111F

SUFFIX: HALOGEN FREE
 PACKAGE
 1: TRAY
 HOUSING COLOR
 1: BLACK
 CONTACT PLATING
 1: GOLD FLASH ON CONTACT AREA,
 150u" TIN ON SOLDER AREA,
 50u" NICKEL UNDERPLATED.

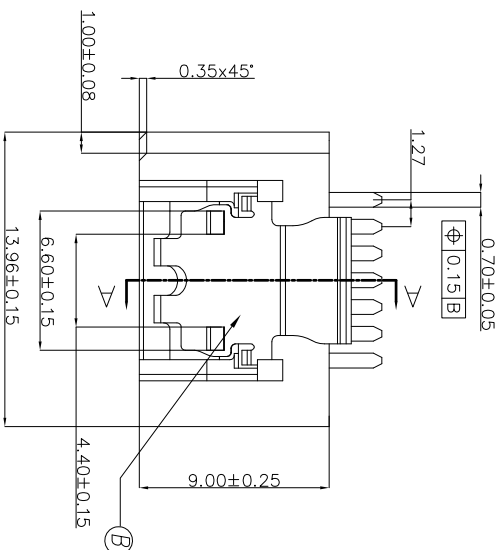

RECOMMEND PCB1.6 LAYOUT

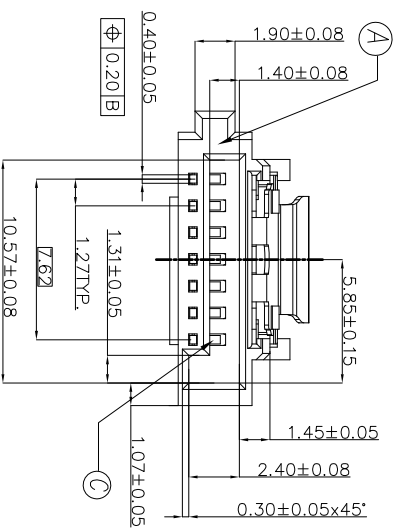
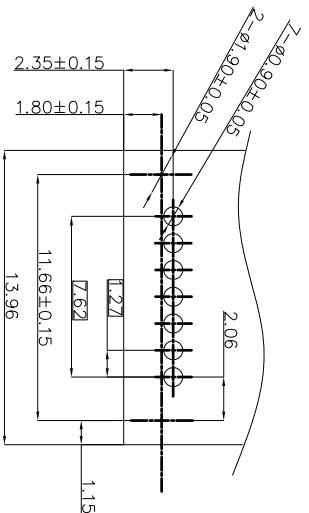

SECTION A-A
 SCALE 1 : 1

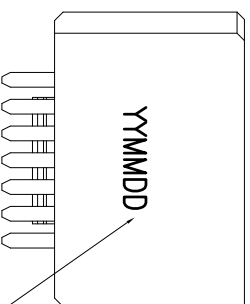
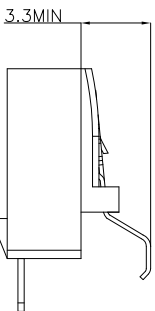

DATE CODE

| NO | DESCRIPTION | QTY | MATERIAL | PLATING & COLOR |
|----|-------------|-----|--------------------------|-----------------|
| D | INK | | | BLACK |
| C | CONTACT | 7 | COPPER ALLOY | SEE PART NO. |
| B | SPRING | 1 | STAINLESS STEEL | |
| A | HOUSING | 1 | HIGH TEMP. THERMOPLASTIC | BLACK |

UNLESS OTHERWISE SPECIFIED TOLERANCES

DECIMALS: ANGLES:

X :±0.5 X :±2°
 X.X :±0.3 X.X :±1°
 X.XX :±0.2

Singatron Enterprise Co., Ltd.
 信音企業股份有限公司

SATA 7P RECEPTACLE, VERTICAL, DIP TYPE

REV. C 2012.02.23 PART NO. 2ST1523-000111F

CHKD IY-C 2012.02.23 SCALE 4:1 UNIT: mm

APVD IY-C 2012.02.23 SIZE: A3 SHEET: 1 OF 1 REV: A

CUSTOMER COPY