

REV.	ECN NO OR DESCRIPTION	REVISED	DATE
A	PDR NO: T130621-6A	WINNIE	20131212
B	ECN NO:S131254	YUREN	20140530

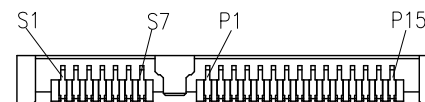

SPECIFICATIONS:

1. HALOGEN PRODUCT IDENTIFICATION LABEL ON PACKAGING:
2. PACKAGING: TRAY
3. REFLOW SOLDER CAPABLE TO 260°C MAX.

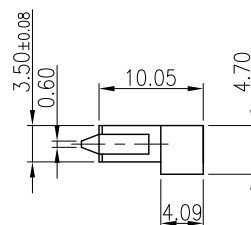
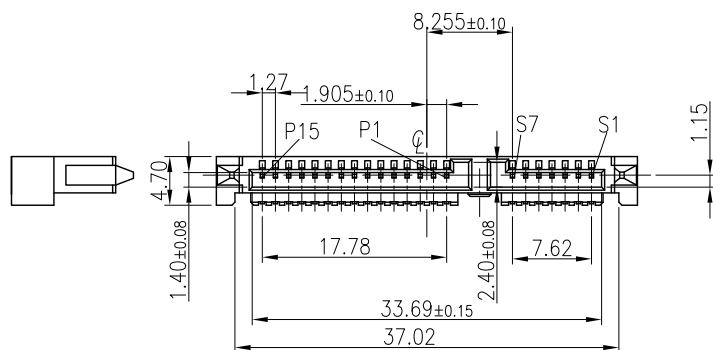
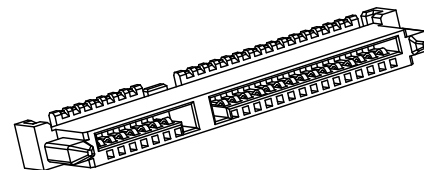
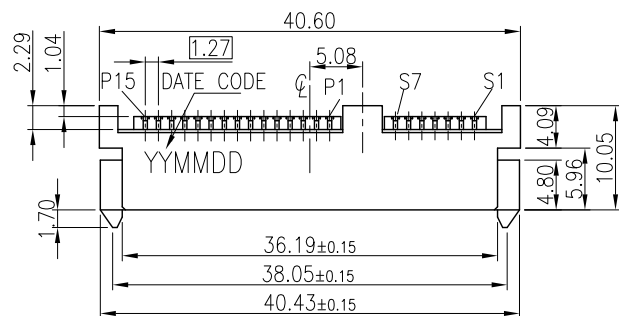
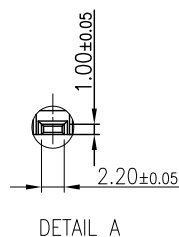
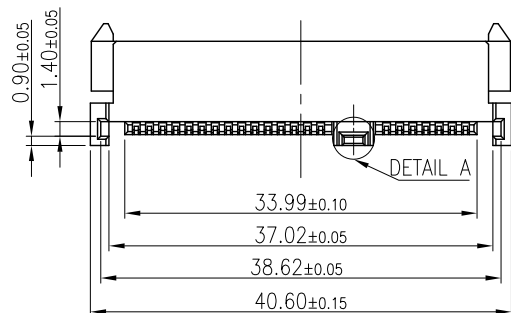

C	TERMINAL 2	15	PHOSPHOR BRONZE	AU 10u" ON CONTACT AREA
B	TERMINAL 1	7	T=0.2mm	ALL OVER NICKEL 50u"min
A	HOUSING	1	LCP HF, UL 94V-0	BLACK
NO	DESCRIPTION	QTY	MATERIAL	PLATING & COLOR
UNLESS OTHERWISE SPECIFIED TOLERANCES			Singatron Enterprise Co., Ltd. 信音企業股份有限公司	
DECIMALS:		ANGLES:		TITLE
X	:±0.5	X	:±2°	DWN YUREN PART NO.2ST3Y77-000112F
X.X	:±0.3	X.X	:±1°	CHKD CERRY SCALE:2:1 UNIT: mm
X.XX	:±0.2			APVD MAX SIZE: A3 SHEET:1 OF 1 REV:B

CUSTOMER COPY