

REV	ECN NO OR DESCRIPTION	REVISED	DATE
A	PDR NO: T131007-9A	Edi.Zhou	20140701
B	ECN NO:S150145	YUREN	20150319

SPECIFICATIONS:

- ELECTRICAL CHARACTERISTICS:
 - RATING: 12V 1A
 - CONTACT RESISTANCE: 30MΩ MAX (INITIAL)
 - DIELECTRIC WITHSTANDING VOLTAGE: 500V AC FOR ONE MINUTE
 - INSULATION RESISTANCE: 100MΩ MIN. MEASURED BY 500 VDC
- MECHANICAL CHARACTERISTICS:
 - INSERTION FORCE : 45N MAX.
 - WITHDRAWAL FORCE : 10N MIN.
 - LIFE TEST: 500 CYCLES MIN.
 - OTHER GENERAL SPEC. TO REFER "2ST3Y78-000111F_SPEC".
 - TO CONFORM TO SINGATRON HAZARDOUS SUBSTANCE FREE SPECIFICATION
 - HALOGEN FREE PRODUCT IDENTIFICATION LOGO ON PACKAGING: 
 - FOR REFLOW SOLDERING LEAD-FREE PROCESS.
 - PACKAGING:TAPE&REEL

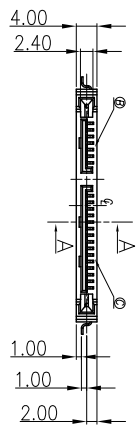
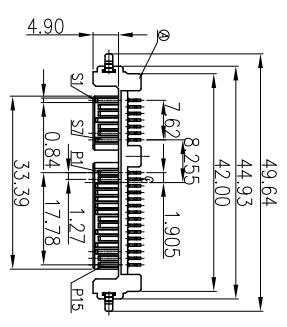

SECTION A-A

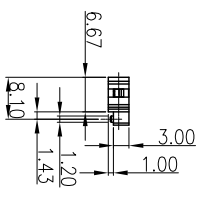

SECTION A-A
SCALE 2:1

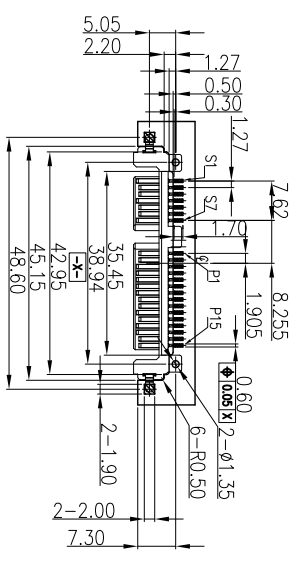
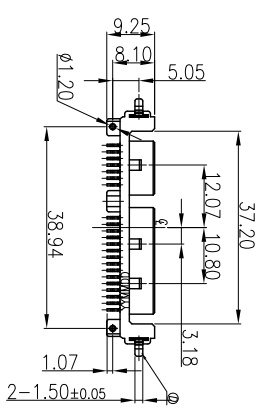
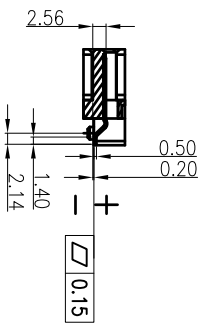

RECOMMEND PCB LAYOUT (TOP VIEW)
T=1.20, TOLERANCE:±0.05

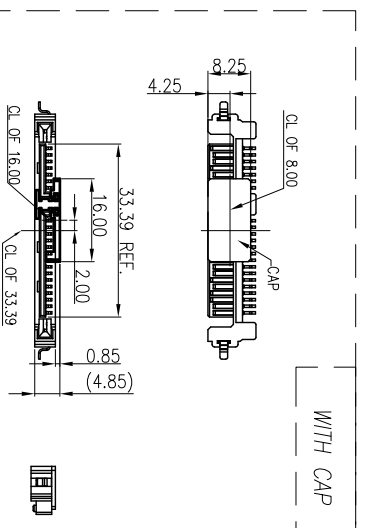

E	CAP	1	LCP HF, UL 94V-0	BLACK
D	FORK	2	BRASS T=0.30mm	WATE-TIN 100U" MIN PLATED OVER NI 50U MIN.
C	TERMINAL 2	15	BRASS T=0.25mm	BOLD FLASH PLATED ON WATING AREA WATE-TIN 100U" MIN ON SOLDER TAIL ALL OVER NI 50U" MIN.
B	TERMINAL 1	7		
A	HOUSING	1	LCP HF, UL 94V-0	BLACK
NO	DESCRIPTION	QTY	MATERIAL	PLATING & COLOR
UNLESS OTHERWISE SPECIFIED TOLERANCES				
 Singatron Enterprise Co., Ltd. 信音企業股份有限公司				
DECIMALS: ANGLES:				
X	:±0.5	X	:±2°	
X.X	:±0.3	X.X	:±1°	
X.XX	:±0.2			
TITLE: SATA 7+15P MALE PLUG				
DMN: YUREN PART NO.2ST3Y78-000111F				
CHKD: Carry SCALE:2:1 UNIT: mm				
APVD: Liao SIZE: A3 SHEET:1 OF 1 REV:B				
CUSTOMER COPY				