

REV.	ECN NO OR DESCRIPTION	REVISED	DATE
A	PDR NO.:A180423-5A~5C	Jun	2018.11.20
B	ECN NO.:A190203-C	Jun	2019.02.14
C	ECN NO.:S202211-R09	MF	2022.11.15

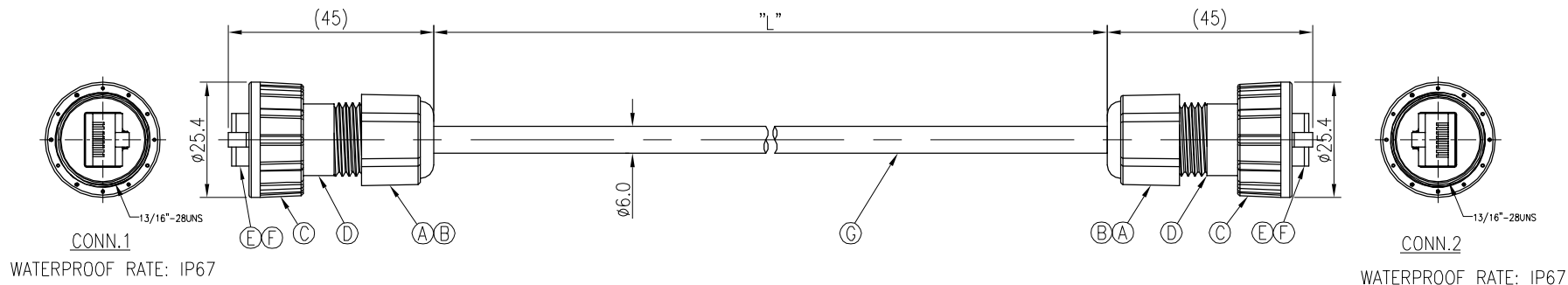

PART NO	"L"mm	PART NO
2TJ3000-W05123H	L=150+10	720.04059.01
2TJ3000-W05124H	L=460+10	720.04061.01
2TJ3000-W05125H	L=2000+100	

SHIELD	DRAIN	SHIELD
8	BROWN	8
7	BROWN/WHITE	7
6	GREEN	6
5	BLUE/WHITE	5
4	BLUE	4
3	GREEN/WHITE	3
2	ORANGE	2
1	ORANGE/WHITE	1
CONN.1	WIRE COLOR	CONN.2

NOTES:

- WATERPROOF RATE: IP67(WHEN PROPERLY MATED)  
IP67: IMMERSED IN 1M WATER FOR 30 MINUTES
- ELECTRICAL CHARACTERISTICS:  
1-1. RATING:125V 1.5A  
1-2. CONTACT RESISTANCE: 30mΩ MAX.(INITIAL)  
1-3. DIELECTRIC WITHSTANDING VOLTAGE: 750V AC FOR ONE MINUTE  
1-4. INSULATION RESISTANCE: 500MΩ MIN. MEASURED BY 500 VDC
- OTHER GENERAL SPEC. TO REFER "RJ45 SERIES SPEC".
- TO CONFORM TO SINGATRON HAZARDOUS SUBSTANCE FREE SPEC.
- GREEN PRODUCT IDENTIFICATION LABEL ON PACKAGING: **G.P. PASS**

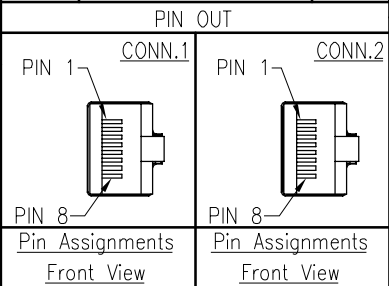

G	CABLE	1	CAT.5e FTP 24AWG*4P +My+D+Al/My	BLACK (UL813)
F	RJ45 PLUG	2	CAT5E RJ45 FTP PLUG	N/A
E	GASKET	2	SILICONE	BLACK
D	CLAMP RING	2	PC 9330	BLACK
C	SCREW NUT	2	PC 9330	BLACK
B	SEAL	2	EPDM	BLACK
A	SEALING NUT	2	PA66 FR370	BLACK
NO	DESCRIPTION	QTY	MATERIAL	PLATING & COLOR
UNLESS OTHERWISE SPECIFIED TOLERANCES			Suzhou Singatron Auto Electronics CO.,LTD. 蘇州信音汽車電子有限公司	
DECIMALS:		ANGLES:		TITLE
X :±0.5		X :±2°		WATERPROOF RJ45 PLUG
X.X :±0.3		X.X :±1°		DWN MF <b>PART NO.2TJ3000-W051XXH</b>
X.XX :±0.2				CHKD JF SCALE 1:1 UNIT: mm
				APVD Steve SIZE: A3 SHEET:1 OF 1 REV: C
<b>CUSTOMER COPY</b>				