

REV.	ECN NO.	OR DESCRIPTION	REVISED	DATE
A	PDR NO:T100226-1A		Shown	2010.07.08
B	ECN NO:SI30725		YF	2014.08.13

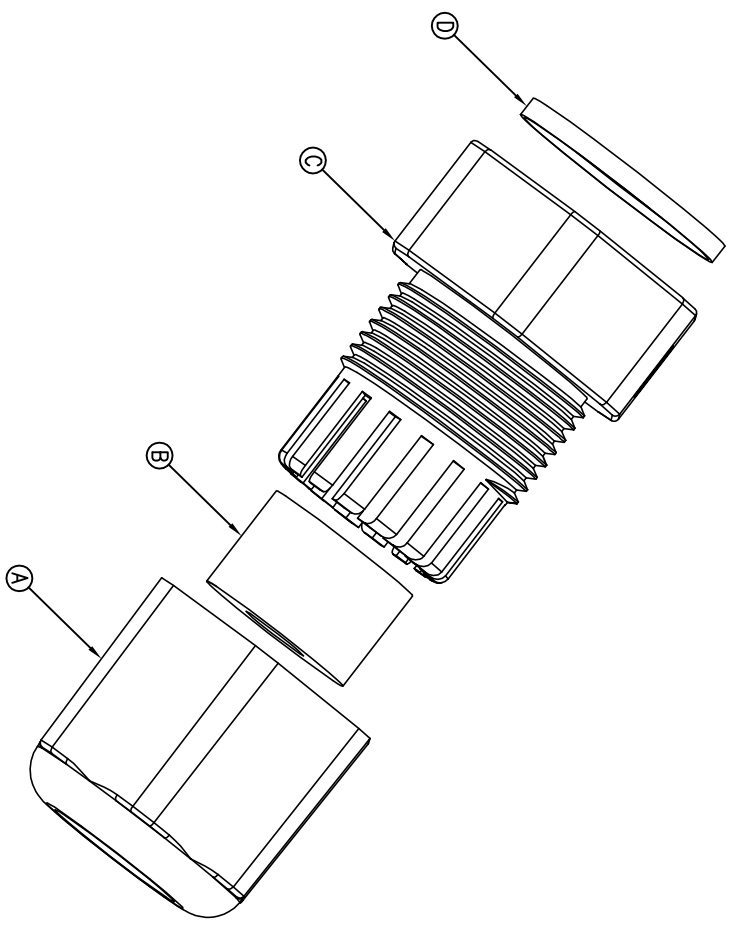
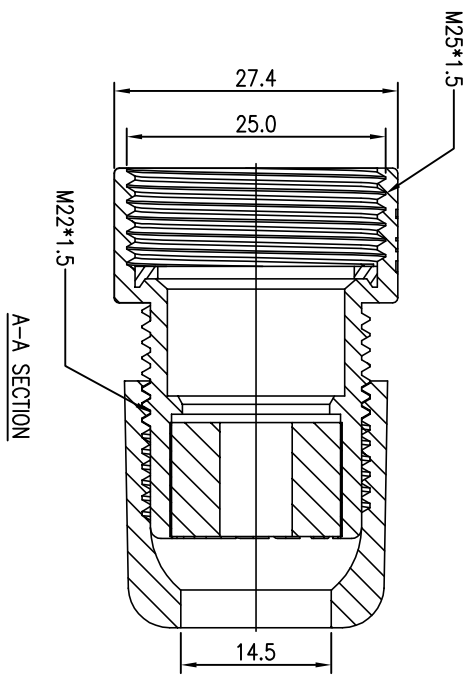
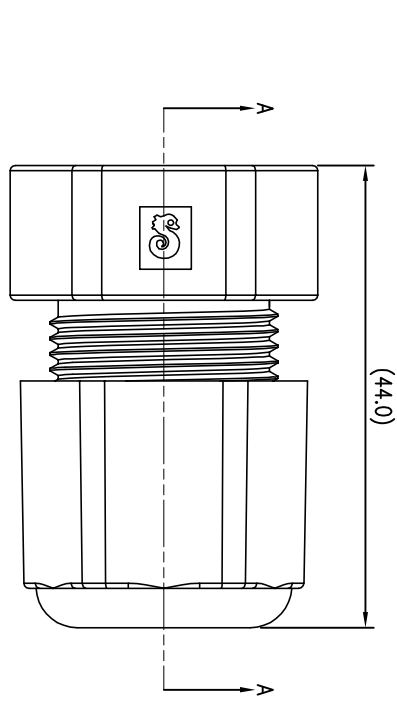

- NOTES:
1. 以中心線為基準標註之尺寸, 對中心線標註者在 0.05 以內.
 2. GENERAL FLASH: 0.05mm max
 3. TO CONFORM TO SINGATRON HAZARDOUS SUBSTANCE FREE SPEC.
 4. GREEN PRODUCT IDENTIFICATION LABEL ON PACKAGING: G27 PASS
 5. SEAL FOR CABLE OD: ϕ :4.0MM~ ϕ :6.5MM

D	GASKET	1	SILICONE	BLACK
C	CLAMP RING	1	PC	BLACK
B	SEAL	1	EPDM 50°	BLACK
A	SEALING NUT	1	PC	BLACK
NO	DESCRIPTION	QTY	MATERIAL	PLATING & COLOR

UNLESS OTHERWISE SPECIFIED TOLERANCES

DECIMALS:		ANGLES:	
X	: \pm 0.5	X	: \pm 2°
X.X	: \pm 0.3	X.X	: \pm 1°
X.XX	: \pm 0.2		
TITLE		R445 CABLE GLAND	
DWN	YF	PART NO.	2733002-W00001
CHKD	Harlen	SCALE	2:1 UNIT: mm
APVD	Steve	SIZE: A3	SHEET: 1 OF 1 REV: B

CUSTOMER COPY

Singatron Enterprise Co., Ltd.
信晉企業股份有限公司