

REV.	ECN NO.	OR DESCRIPTION	REVISED	DATE
A	PDR NO.:S110112-3A		Glen	2011.08.10
B	ECN NO.:S130725		YF	2014.08.13

- NOTES:
1. WATERPROOF RATE: IP67(WHEN PROPERLY MATED)
IP67: IMMERSED IN 1M WATER FOR 30 MINUTES
 2. ELECTRICAL CHARACTERISTICS:
 - 1-1. RATING:125V 1.5A
 - 1-2. CONTACT RESISTANCE: 30 mΩ MAX.(INITIAL)
 - 1-3. DIELECTRIC WITHSTANDING VOLTAGE: 500V AC FOR ONE MINUTE
 - 1-4. INSULATION RESISTANCE: 30MΩ MIN. MEASURED BY 300 VDC
 3. OTHER GENERAL SPEC. TO REFER "RJ45 SERIES SPEC."
 4. TO CONFORM TO SINGATRON HAZARDOUS SUBSTANCE FREE SPEC.
 5. GREEN PRODUCT IDENTIFICATION LABEL ON PACKAGING: **G.P. PASS**
 6. FOR PANEL THICKNESS MAX OF 4.0mm

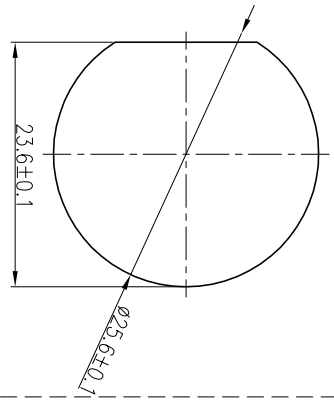
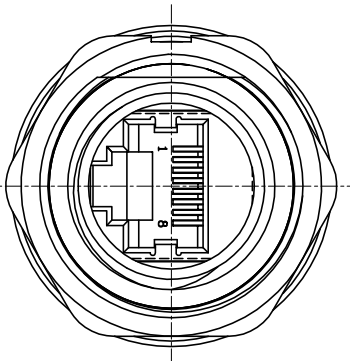
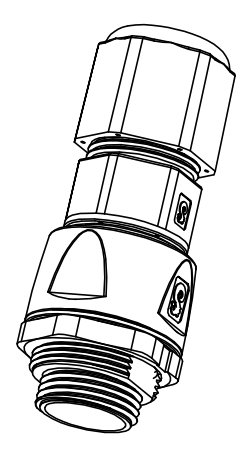
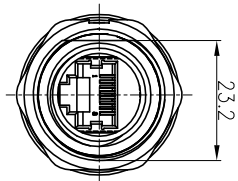
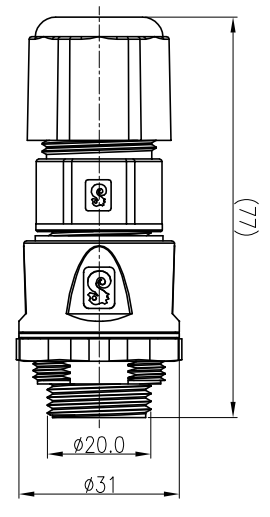
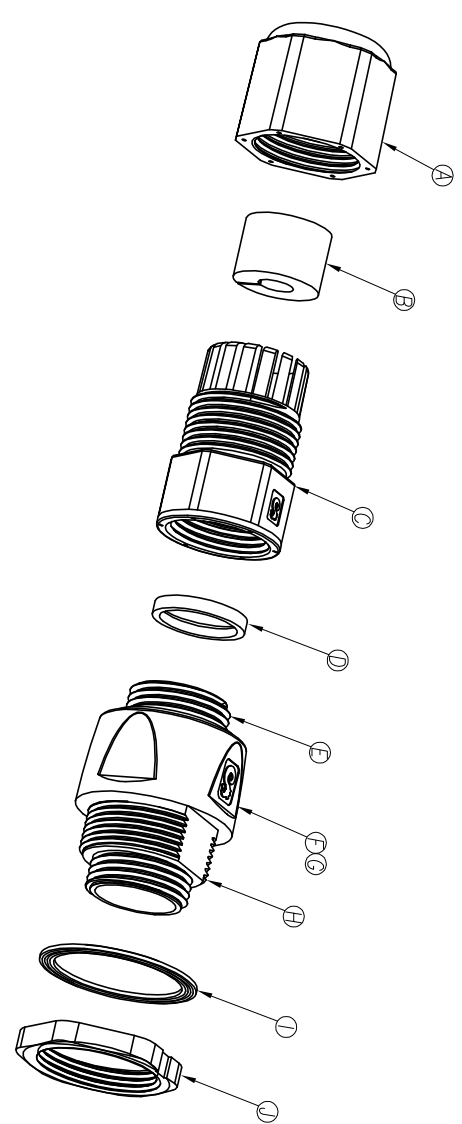

PIN ASSIGNMENTS
FRONT VIEW

RECOMMENDED
PANEL CUT-OUT

J	SCREW NUT	1	NYLON+33%GF	BLACK
I	GASKET	1	EPDM	BLACK
H	HOUSING	1	ABS UL94V-0	BLACK
G	RJ45 JACK	1	CAT5E STP	N/A
F	OVER MOLD	1	PVC	BLACK
E	HOUSING	1	ABS UL94V-0	BLACK
D	GASKET	1	SILICONE	BLACK
C	CLAMP RING	1	PC	BLACK
B	SEAL	1	SILICONE	BLACK
A	SEALING NUT	1	PC	BLACK
NO	DESCRIPTION	QTY	MATERIAL	PLATING & COLOR

UNLESS OTHERWISE SPECIFIED TOLERANCES

DECIMALS: ANGLES:

X :±0.5 X :±2°
X.X :±0.3 X.X :±1°
X.XX :±0.2

TITLE: PANEL AND INLINE CONFIGURATION
RJ45 NETWORK SOLUTION

Singatron Enterprise Co., Ltd.
信登企業股份有限公司

DWN YF PART NO.2T33002-W05101
CHKD Harden SCALE:1:1 UNIT: mm
APVD Steve SIZE: A3 SHEET: 1 OF 1 REV: B

CUSTOMER COPY