

REV.	ECN NO. OR DESCRIPTION	REVISED	DATE
A	PDR NO.:A181016-3A	JAY	2018.10.17
B	ECN NO.:A181214-R/B	MF	2019.01.23

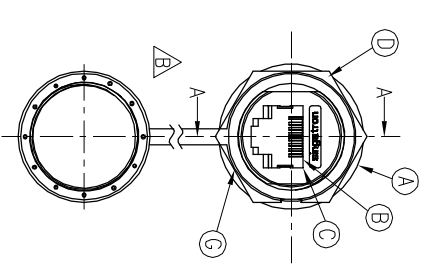
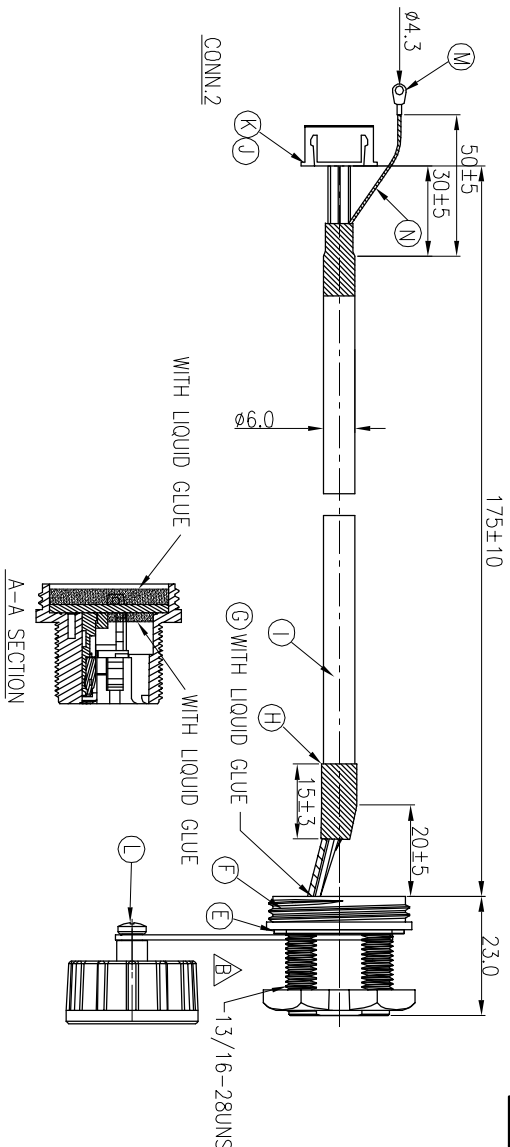
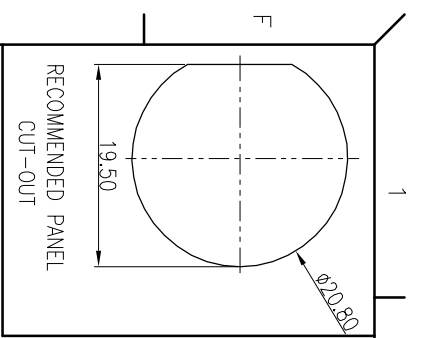

WATERPROOF RATE: IP67

SHIELD	DRAIN	SHIELD
1	ORANGE/WHITE	1
2	ORANGE	2
3	GREEN/WHITE	EARTH
4	BLUE	
5	BLUE/WHITE	
6	GREEN	EARTH
7	BROWN/WHITE	
8	BROWN	3
CONN.1	WIRE COLOR	CONN.2
	PIN OUT	
	PIN 1	CONN.1
	PIN 8	CONN.2
		PIN4
		PIN1

CONNECT TOGETHER WITH SHIELD  
LEAD WIRE.TOTAL THREE LEAD WIRES  
CONNECT TO RING TERMINAL

N	TUBE	1	Ø3.5 L=50MM	BLACK
M	O-TERMINAL	1	Ø4.3 SKT RNBS2-4 N1	N/A
L	WATERPROOF	1	P/N:2UB3001-W0000W	BLACK
K	TERMINAL	4	TYU TER:TU3001TPO-A	TIN-PLATED
J	HOUSING	1	TYU HSG:TU3001HNO-04	WHITE
I	CABEL	1	UL CATSE FTP 24#* 4P+D+AL/MY OD:6.0	BLACK(PVC JACKET)
H	TUBE	2	Ø7.0*15 125°C 300V	BLACK
G	LIQUID	2	N/A	BLACK
F	SCREW	1	ST2.2*5.0	N/A
E	GASKET	1	SILICONE	BLACK
D	NUT	1	NYLON+GF	BLACK
C	GROUND	2	BRASS	NICKEL PLATING
B	RJ45	1	N/A	GOLD PLATING
A	HOUSING	1	NYLON+GF	BLACK
NO	DESCRIPTION	QTY	MATERIAL	PLATING & COLOR

UNLESS OTHERWISE SPECIFIED TOLERANCES		 Singatron Enterprise Co., Ltd. 信亨企業股份有限公司	
DECIMALS:	ANGLES:	TITLE FRONT MOUNT CONN.+PLUG	
X :±0.5	X :±2°	DWN	MF
XX :±0.3	XX :±1°	CHKD	Cerry
X:XX :±0.2		APVD	William
		PART NO.2TJ3003-W051E7H	
		SCALE 2:1 UNIT: mm	
		SIZE: A3 SHEET: 1 OF 1	
		REV: B	

CUSTOMER COPY	
---------------	--

- NOTES:
1. WATERPROOF RATE: IP67
  2. RATING:125V 1.5A
  3. OTHER GENERAL SPEC. TO REFER "RJ45 SERIES SPEC."
  4. TO CONFORM TO SINGATRON HAZARDOUS SUBSTANCE FREE SPEC.
  5. GREEN PRODUCT IDENTIFICATION LABEL ON PACKAGING:
  6. FOR PANEL THICKNESS MAX OF 5.5mm

