

REV.	ECN NO OR DESCRIPTION	REVISED	DATE
A	PDR NO.:C200109-1B	JAY	2021.05.18
B	ECN NO.:S202305-C17	JAY	2023.05.31

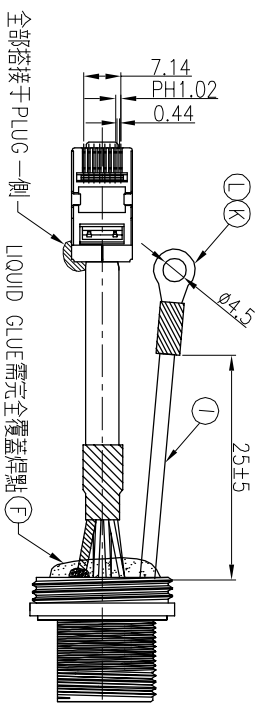
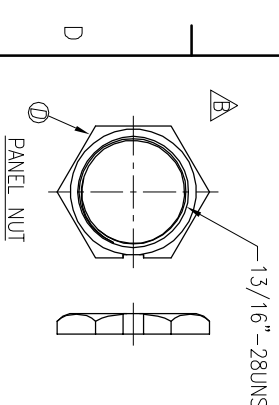
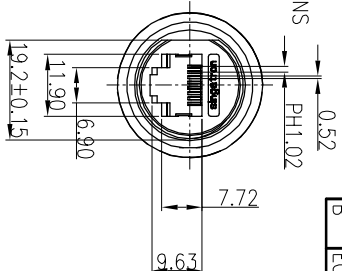
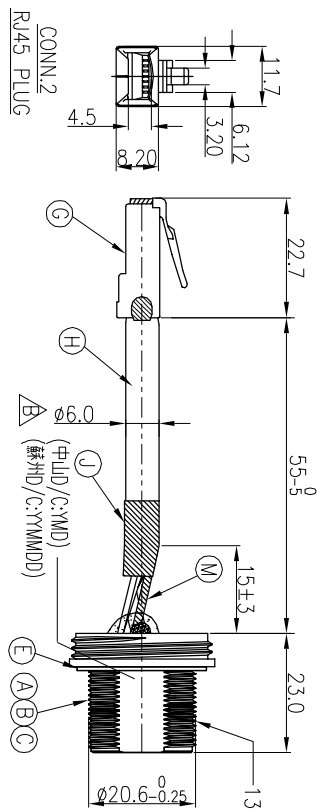
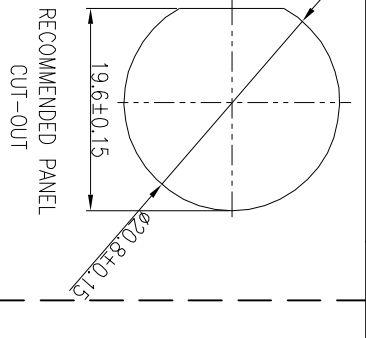

SHIELD	DRAIN+BRAID	SHIELD
8	BROWN	8
7	BROWN/WHITE	7
6	GREEN	6
5	BLUE/WHITE	5
4	BLUE	4
3	GREEN/WHITE	3
2	ORANGE	2
1	ORANGE/WHITE	1

CONN.1 WIRE COLOR

CONN.2

PIN OUT

CONN.1

PIN 1

PIN 8

CONN.2

PIN1

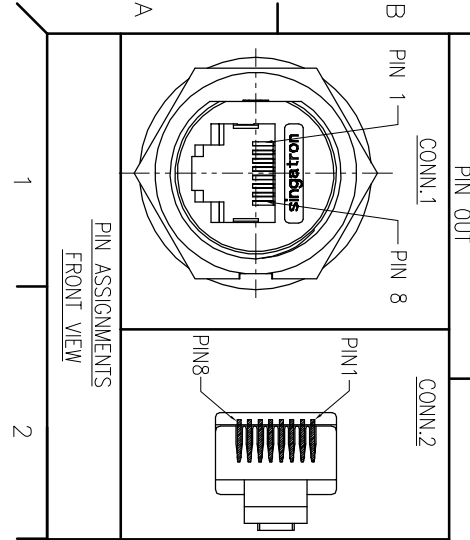
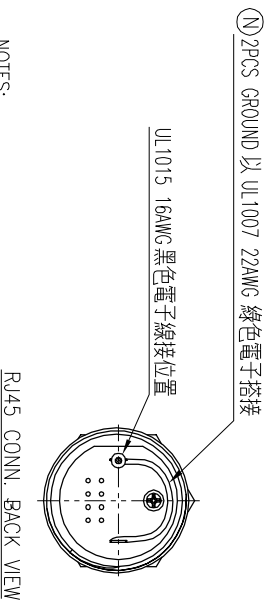

WATERPROOF RATE: IP67

ITEM	DESCRIPTION	QTY	MATERIAL	PLATING & COLOR
N	WIRE	1	UL 1007 22AWG	GREEN
M	HEAT SHINK TUBE	1	Ø1.0 125°C 300V	BLACK
L	HEAT SHINK TUBE	1	Ø4.5 125°C 300V	BLACK
K	O-TERMINAL	1	ID4.5 Ø8.0	TIN PLATED
J	HEAT SHINK TUBE	1	Ø7.0 125°C 300V	BLACK
I	WIRE	1	UL 1015 16AWG	BLACK
H	CABLE	1	CAT5E FTP 24AWG+4P+HV+D+4A/M UV RESISTANT(-40°C~105°C) VW-1	BLACK(PVC JACKET)
G	RJ45 PLUG	1	8P8C SHIELD	Au 50u" ON CONTACT AREA
F	LIQUID GLUE	1	N/A	BLACK
E	GASKET	1	SILICON(SHIN-ETSU KE5612)	DARK GRAY
D	PANEL NUT	1	PA66+GF	BLACK
C	SCREW	1	STAINLESS STEEL	N/A
B	RJ45+PCB	1	CAT.5e	Au 50u" ON CONTACT AREA
A	BODY	1	PA66+GF	BLACK
NO	DESCRIPTION	QTY	MATERIAL	PLATING & COLOR

UNLESS OTHERWISE SPECIFIED TOLERANCES

DECIMALS: ANGLES:

X :±0.5 X :±2°

XX :±0.3 X.X :±1'

X:XX :±0.2

© Suzhou Singatron Auto Electronics CO.,LTD.
蘇州信譽汽車電子有限公司

PART NO.:2TJ3003-W051K6H

SCALE 2:1 UNIT: mm

SIZE: A3 SHEET: 1 OF 1 REV: B

CUSTOMER COPY