

REV	ECN NO OR DESCRIPTION	REVISED	DATE
A	PDR NO.:A200922-3A	JAY	2020.12.03
B	ECN NO.:S202101-R23	MF	2021.03.03
C	ECN NO.:S202107-C08	JAY	2021.07.15

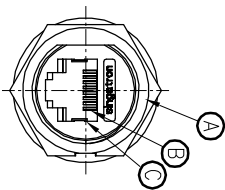

CONN.1  
WATERPROOF RATE: IP67

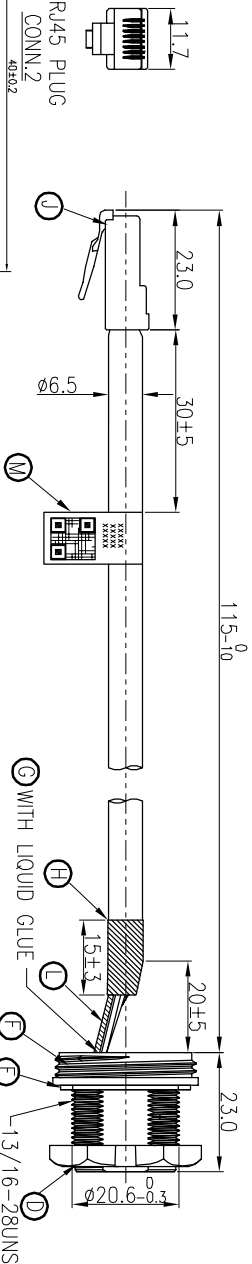
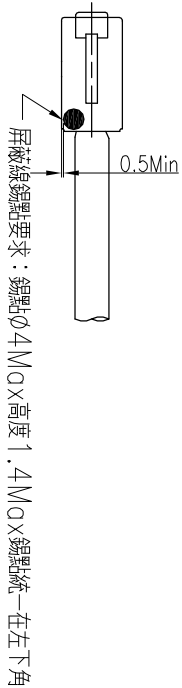
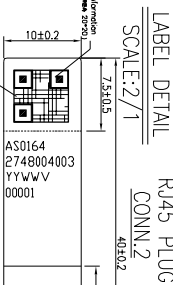

二維碼標識信息表  
AS01642748004003YVWV00001  
02748004003  
YVWV  
10000  
00001  
00001-999999

- NOTES:
1. WATERPROOF RATE: IP67  
IP67: IMMERSED IN 1M WATER FOR 30 MINUTES
  2. RATING:125V 1.5A
  3. OTHER GENERAL SPEC. TO REFER "RJ45 SERIES SPEC."
  4. TO CONFORM TO SINGATRON HAZARDOUS SUBSTANCE FREE SPEC.
  5. GREEN PRODUCT IDENTIFICATION LABEL ON PACKAGING:
  6. FOR PANEL THICKNESS MAX OF 5.5mm
  7. Bar code printing:  
THE BARCODE SHALL BE PRINTED BY THE MANUFACTURER ACCORDING TO THE SHIPMENT SCHEDULE, AND THE PRODUCTION SCHEDULE SHALL BE PRINTED DURING THE PRODUCTION CYCLE.  
THE FLOW CODE IN THE BAR CODE IS ARRANGED FROM 00001 TO THE LAST ONE OF THE PRODUCTION IN THE SAME WEEK ACCORDING TO THE PRODUCTION QUANTITY OF THE FILE WEEK.

SHEET	DRAIN	SHEET
8	ORANGE/WHITE	8
7	ORANGE	7
6	GREEN/WHITE	6
5	BLUE	5
4	BLUE/WHITE	4
3	BROWN/WHITE	3
2	BROWN	2
1	BROWN	1

CONN.1 WIRE COLOR CONN.2

INCIDENTAL BUT NOT ASSEMBLE

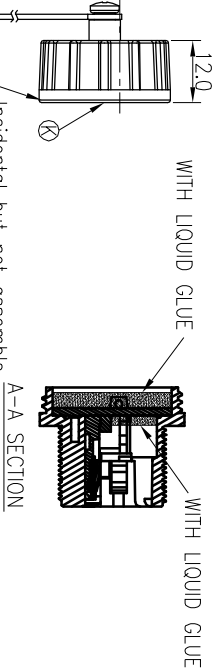

A-A SECTION

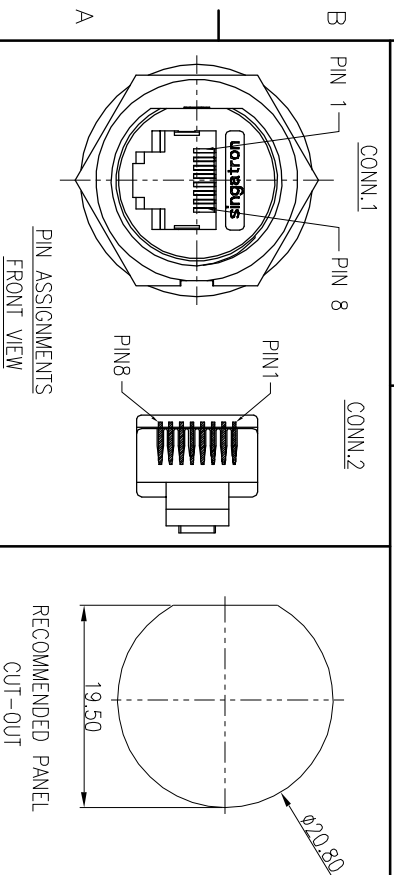

PIN ASSIGNMENTS  
FRONT VIEW

RECOMMENDED PANEL  
CUT-OUT

1 2 3 4 5 6 7 8

文件編號: RD-06-043-A

NO	DESCRIPTION	QTY	MATERIAL	PLATING & COLOR
A	HOUSING	1	NYLON+30%GF 94V-0	BLACK
B	CRJ45	1	N/A	Au15"ON CONTACT AREA
C	GROUND	2	BRASS	NICKEL PLATING 60U"
D	NUT	1	PPE	BLACK
E	GASKET	1	EPDM	BLACK
F	SCREW	1	STAINLESS STEEL	N/A
G	LIQUID GLUE	1	N/A	BLACK
H	TUBE	1	φ6.0 125°C 300V	BLACK
M	LABEL	1	L40*W10mm	WHITE
L	TUBE	1	φ1.0 125°C 300V	BLACK
K	WATERPROOF CAP	1	P/N:ZUB3001-W0000W	BLACK
J	RJ45 PLUG	1	8P8C SHIELD	Au15"ON CONTACT AREA
I	CABEL	1	CAT5E FTP 24#*4P+MY+D +A/M UV RESISTANT	BLACK(PVC JACKET)

UNLESS OTHERWISE SPECIFIED TOLERANCES

DECIMALS: ANGLES:  
X :±0.5 X :±2  
X.X :±0.3 X.X :±1  
X.XX :±0.2

TITLE	RJ45 SHIELDED JACK + PLUG		
DWN	JAY	PART NO.2TJ3003-W051M9H	
CHKD	JF	SCALE 2:1	UNIT: mm
APVD	JF	SIZE: A3	SHEET: 1 OF 1 REV: C

CUSTOMER COPY

Suzhou Singatron Auto Electronics CO.,LTD.  
蘇州信音汽車電子有限公司