

WATERPROOF RATE: IP67

SHIELD	DRAIN	
1	ORANGE/WHITE	TWIST
2	ORANGE	TWIST
3	GREEN/WHITE	TWIST
4	BLUE	TWIST
5	BLUE/WHITE	TWIST
6	GREEN	TWIST
7	BROWN/WHITE	TWIST
8	BROWN	TWIST
CONN.1	WIRE COLOR	
	PIN OUT	
	CONN.1	

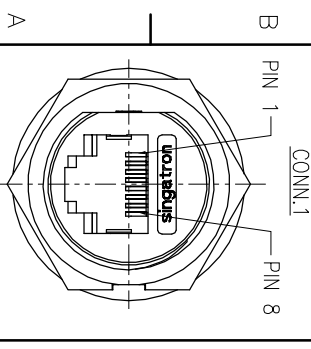

- NOTES:
1. WATERPROOF RATE: IP67
IP67: IMMersed IN 1M WATER FOR 30 MINUTES
 2. RATING:125V 1.5A
 3. OTHER GENERAL SPEC. TO REFER "RJ45 SERIES SPEC".
 4. TO CONFORM TO SINGATRON HAZARDOUS SUBSTANCE FREE SPEC.
 5. GREEN PRODUCT IDENTIFICATION LABEL ON PACKAGING:
 6. FOR PANEL THICKNESS MAX OF 5.5mm

REV	ECN NO OR DESCRIPTION	REVISED	DATE
A	PDR NO.: A210406-2A	JAY	2021.10.13

J	TUBE	1	Ø1.0 125°C 300V	BLACK
I	CABEL	1	UL CAT5E FTP 24#* 4P+D+AL/MY OD:6.0	BLACK(PVC JACKET)
H	TUBE	1	Ø7.0*15 125°C 300V	BLACK
G	LIQUID GLUE	2	N/A	BLACK
F	SCREW	1	ST2.2*5.0	N/A
E	GASKET	1	SILICONE	BLACK
D	NUT	1	NYLON+GF	BLACK
C	GROUND	2	BRASS	NICKEL PLATING
B	RJ45	1	N/A	GOLD PLATING
A	HOUSING	1	NYLON+GF	BLACK
NO	DESCRIPTION	QTY	MATERIAL	PLATING & COLOR
UNLESS OTHERWISE SPECIFIED TOLERANCES				
Suzhou Singatron Auto Electronics CO.,LTD. 蘇州信音汽車電子有限公司				
DECIMALS:		ANGLES:		
X	:±0.5	X	:±2°	
XX	:±0.3	XX	:±1'	
X:XX	:±0.2			
TITLE		RJ45 FRONT MOUNT CONN.+PLUG		
DWN	JAY	PART NO.2TJ3003-W051P7H		
CHKD	JF	SCALE	2:1	UNIT: mm
APVD	Steve	SIZE: A3	SHEET: 1 OF 1	REV: A
CUSTOMER COPY				