

WATERPROOF RATE: IP67

SHIELD	DRAIN
1	ORANGE/WHITE
2	ORANGE
3	GREEN/WHITE
4	BLUE
5	BLUE/WHITE
6	GREEN
7	BROWN/WHITE
8	BROWN
CONN.1	WIRE COLOR
	PIN OUT
	CONN.1

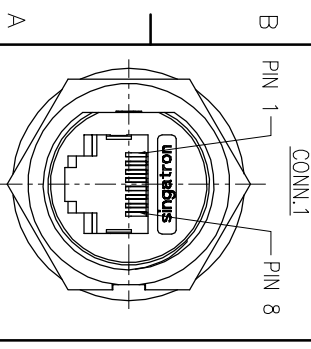

- NOTES:
1. WATERPROOF RATE: IP67  
IP67: IMMersed IN 1M WATER FOR 30 MINUTES
  2. RATING:125V 1.5A
  3. OTHER GENERAL SPEC. TO REFER "RJ45 SERIES SPEC".
  4. TO CONFORM TO SINGATRON HAZARDOUS SUBSTANCE FREE SPEC.
  5. GREEN PRODUCT IDENTIFICATION LABEL ON PACKAGING:
  6. FOR PANEL THICKNESS MAX OF 5.5mm

REV	ECN NO OR DESCRIPTION	REVISED	DATE
A	PDR NO.: A210419-1B	JAN	2021.07.23

J	TUBE	1	Ø1.0 125°C 300V	BLACK
I	CABEL	1	UL CAT5E FTP 24#* 4P+D+AL/MY OD:6.0	BLACK(PVC JACKET)
H	TUBE	1	Ø7.0*15 125°C 300V	BLACK
G	LIQUID GLUE	2	N/A	BLACK
F	SCREW	1	ST2.2*5.0	N/A
E	GASKET	1	SILICONE	BLACK
D	NUT	1	NYLON+GF	BLACK
C	GROUND	2	BRASS	NICKEL PLATING
B	RJ45	1	N/A	GOLD PLATING
A	HOUSING	1	NYLON+GF	BLACK
NO	DESCRIPTION	QTY	MATERIAL	PLATING & COLOR
UNLESS OTHERWISE SPECIFIED TOLERANCES				
Suzhou Singatron Auto Electronics CO.,LTD. 蘇州信益汽車電子有限公司				
DECIMALS:		ANGLES:		
X	:±0.5	X	:±2°	
XX	:±0.3	XX	:±1'	
X:XX	:±0.2			
TITLE R445 FRONT MOUNT CONN.+PLUG				
DWN	JAY	PART NO.2TJ3003-W051P9H		
CHKD	JF	SCALE 2:1	UNIT: mm	
APVD	JF	SIZE: A3	SHEET: 1 OF 1	REV: A
CUSTOMER COPY				