

WATERPROOF RATE: IP67

SHIELD	DRAIN
1	ORANGE/WHITE
2	ORANGE
3	GREEN/WHITE
4	BLUE
5	BLUE/WHITE
6	GREEN
7	BROWN/WHITE
8	BROWN
CONN.	WIRE COLOR
PIN DEFINE	

TWIST
TWIST
TWIST

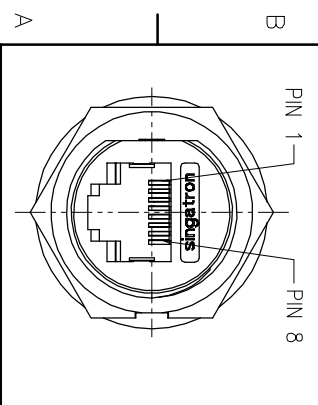
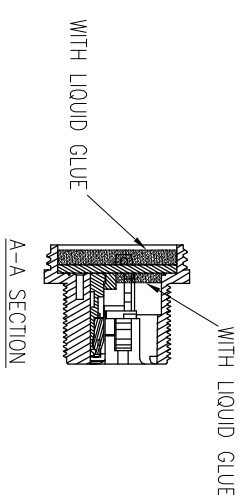

PIN ASSIGNMENTS
FRONT VIEW

- NOTES:
1. WATERPROOF RATE: IP67
IP67: IMMERSED IN 1M WATER FOR 30 MINUTES
 2. RATING:125V 1.5A
 3. OTHER GENERAL SPEC. TO REFER "RJ45 SERIES SPEC."
 4. TO CONFORM TO SINGATRON HAZARDOUS SUBSTANCE FREE SPEC.
 5. GREEN PRODUCT IDENTIFICATION LABEL ON PACKAGING.
 6. FOR PANEL THICKNESS MAX OF 5.5mm

REV.	ECN NO. OR DESCRIPTION	REVISED	DATE
A	PDR NO.:A210825-1C	JAY	2021.12.04
B	ECN NO.:S202205-C05	JAY	2022.04.29
C	ECN NO.:S202208-E11	Erod	2022.10.20

J	TUBE	1	125°C 300V	BLACK
I	CABLE	1	UL CAT5E FTP 24#* 4P+D+AL/MY OD:6.0	BLACK(PVC JACKET)
H	TUBE	1	125°C 300V	BLACK
G	LIQUID GLUE	2	N/A	BLACK
F	SCREW	1	ST2.2*5.0	N/A
E	GASKET	1	SILICONE	BLACK
D	NUT	1	NYLON+GF	BLACK
C	GROUND	2	BRASS	NICKEL PLATING
B	RJ45	1	N/A	GOLD PLATING
A	HOUSING	1	NYLON+GF	BLACK
NO	DESCRIPTION	QTY	MATERIAL	PLATING & COLOR

UNLESS OTHERWISE SPECIFIED TOLERANCES

蘇州信音汽車電子有限公司
Suzhou Singatron Auto Electronics CO.,LTD.

DECIMALS: ANGLES: TITLE
X :±0.5 X :±2° RJ45 FRONT MOUNT CONN.+CABLE
X.X :±0.3 X.X :±1' PART NO.:2TJ3003-W051Q7H
X:XX :±0.2 APVD Steve SCALE 2:1 UNIT: mm SHEET:1 OF 1 REV: C

CUSTOMER COPY