

REV.	ECN NO. OR DESCRIPTION	REVISED	DATE
D	ECN NO:S150834-C	Vicky	2015.08.20
E	ECN NO:S202009-R18	LEI	2020.12.08

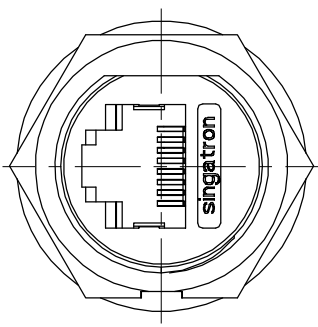

WATERPROOF RATE: IP67

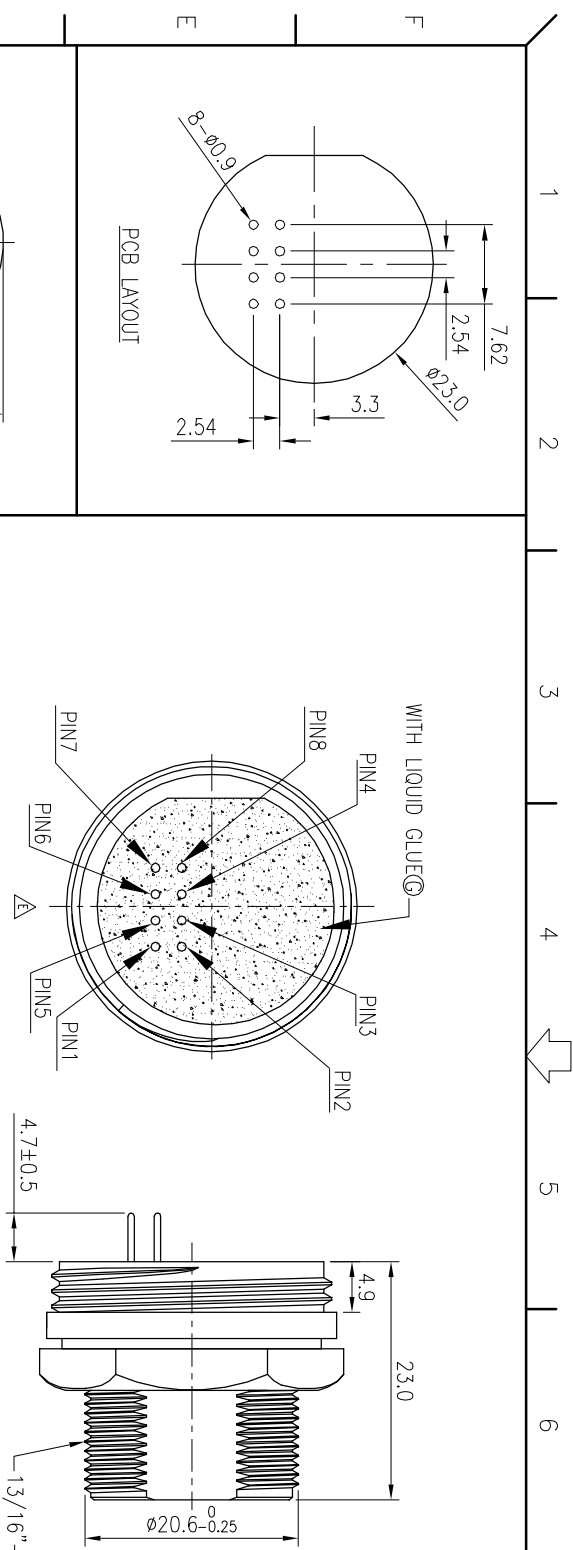
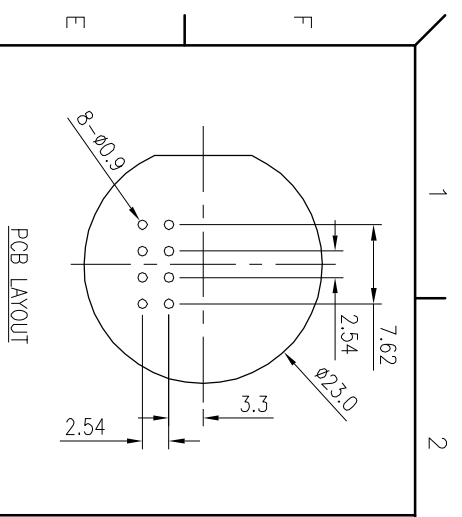
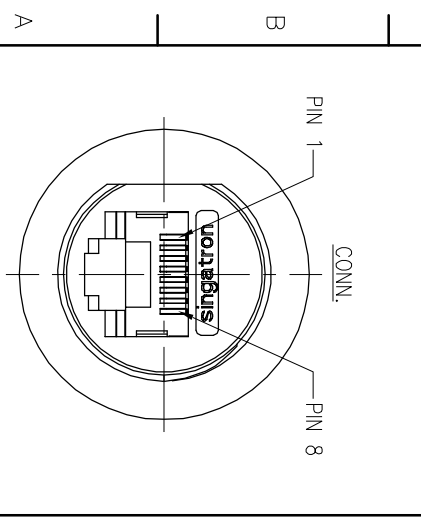
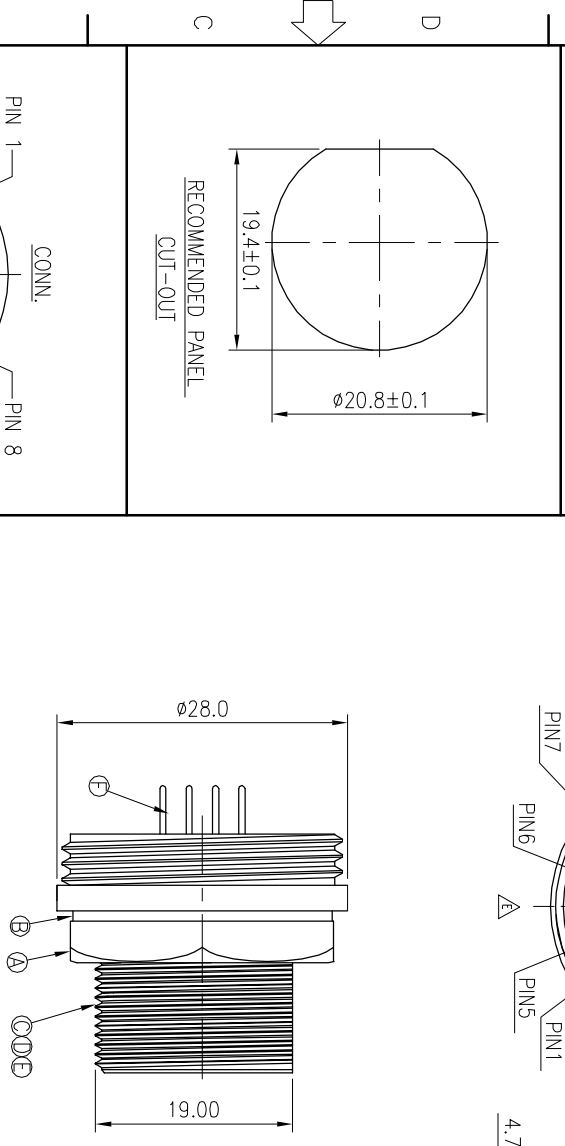
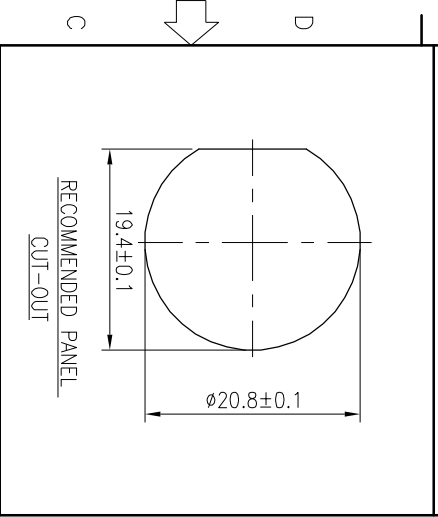

- NOTES:
1. WATERPROOF RATE: IP67
IP67: IMMERSED IN 1M WATER FOR 30 MINUTES
 2. RATING: 125V 1.5A
 3. OTHER GENERAL SPEC. TO REFER "RJ45 SERIES SPEC".
 4. TO CONFORM TO SINGATRON HAZARDOUS SUBSTANCE FREE SPEC.
 5. GREEN PRODUCT IDENTIFICATION LABEL ON PACKAGING:
 6. FOR PANEL THICKNESS MAX OF 4.3mm

G	LIQUID GLUE	1	JA7234/B	BLACK
F	WAFER	1	TYU TU5005MNV-2*4	BLACK
E	CAT 5E CONN	1	P/N:4TU3013-W0000P	N/A
D	SCREW	1	STAINLESS STEEL	N/A
C	HOUSING	1	NYLON+GF	BLACK
B	GASKET	1	EPDM	BLACK
A	PANEL NUT	1	NYLON+GF	BLACK
NO	DESCRIPTION	QTY	MATERIAL	PLATING & COLOR
UNLESS OTHERWISE SPECIFIED TOLERANCES				
Suzhou Singatron Auto Electronics CO.,LTD. 蘇州新格特汽車電子有限公司				
DECIMALS:		ANGLES:		
X	:±0.5	X	:±2°	
X.X	:±0.3	X.X	:±1°	
X.XX	:±0.2			
TITLE: RJ45 CAT 5E KEYSTONE JACK SOCKET				
DWN	LEI	PART NO:	27J3013-W05100H	
CHKD	Gerry	SCALE	1:1	UNIT: mm
APVD	William	SIZE:	A3	SHEET: 1 OF 1
REV: B				
CUSTOMER COPY				