

REV.	EGN NO OR DESCRIPTION	REVISED	DATE
A	PDR NO:TT30408-4A	JAMES	2013.10.02

- SPECIFICATIONS:
1. OTHER GENERAL SPEC. TO REFER "2TJ3101 SERIES SPEC";
  2. TO CONFORM TO SINGATRON HAZARDOUS SUBSTANCE FREE SPEC.
  3. PACKAGE : SEE "2TJ3101 SERIES" PACKAGE.
  4. GREEN PRODUCT IDENTIFICATION LABEL ON PACKAGING;
  5. FOR REFLOW SOLDERING LEAD-FREE PROCESS, 260°~265° FOR 10 SECS.

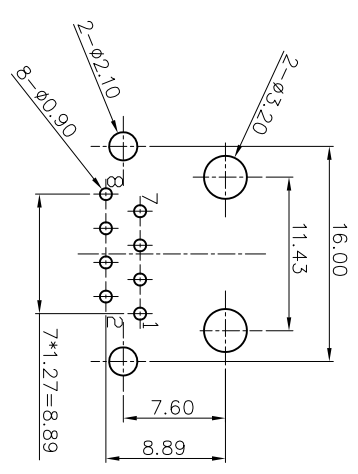

RECOMMENDED PCB LAYOUT  
ALL DIMENSION TOLERANCE ARE ±0.05

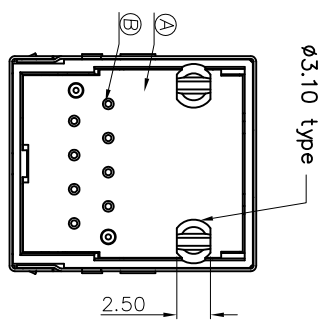
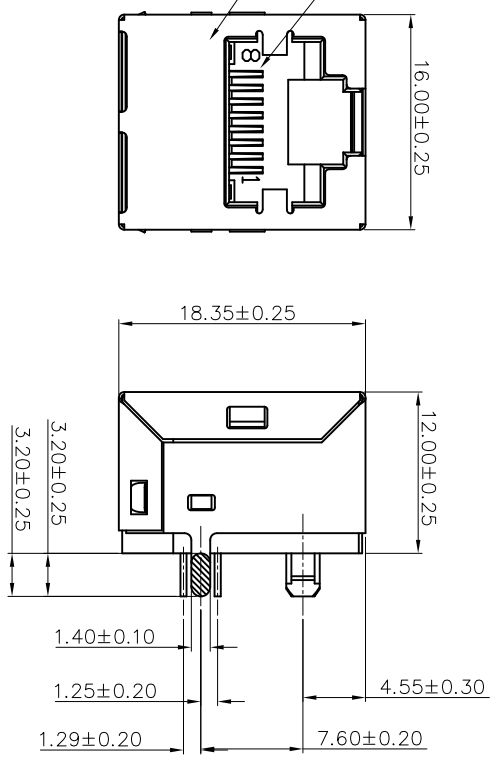
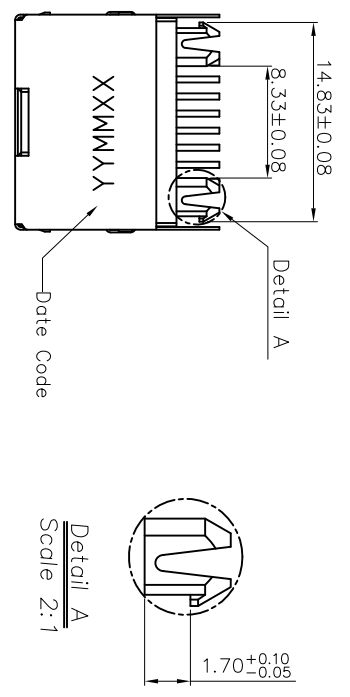
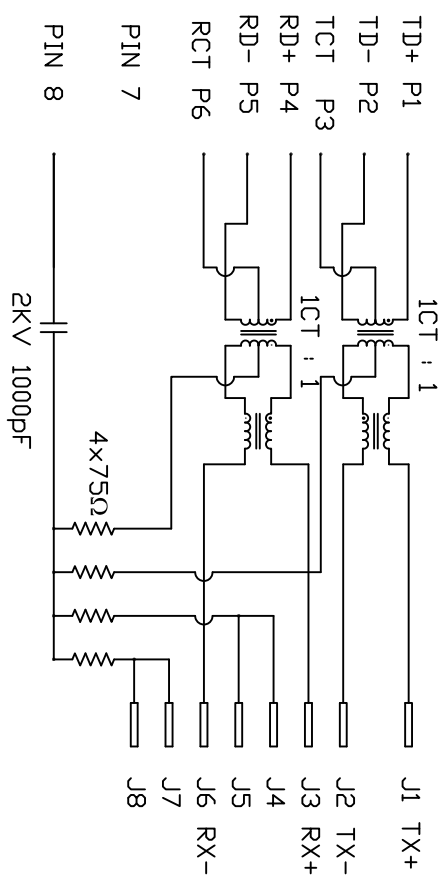

NO	DESCRIPTION	QTY	MATERIAL	PLATING & COLOR
E	PCB	1	PCB	
D	SHELL	1	COPPER ALLOY	
C	OUTPUT CONTACT	8	COPPER ALLOY	GOLD PLATING
B	INPUT CONTACT	8	COPPER ALLOY	TIN PLATING
A	HOUSING	1	HIGH TEMP. MATERIAL	UL 94V-0 & BLACK

UNLESS OTHERWISE SPECIFIED TOLERANCES

Singatron Enterprise Co., Ltd.  
信音企業股份有限公司

DECIMALS:	ANGLES:	TITLE	DWG	CHKD	APVD
: ±0.5	X : ±2°	R045 10/100 BASE-T	ANNE	JAMES	JAMES
: ±0.3	X.X : ±1°	PART NO. 2TJ3101-008111H			
: ±0.2		SCALE: N/A UNIT: mm			
		SIZE: A3 SHEET: 1 OF 1			

CUSTOMER COPY