

# APPROVAL SHEET

To :

Customer P/N :

Singatron P/N : 2TJRB2-ZZ-0062

Description : RJ45 1X2 Tab Down

Through Hole

10/100/1000 Base-T

Contact Area : Gold Flash

LED : L-Green; R-Yellow

Without Shield



Spec No.  
RB218037-00

Update Date  
2018/12/19

Revision  
A

Approved	Checked	Prepared

SINGATRON U.S.A.  
13925 MAGNOLIA AVE  
CHINO, CA 91710 USA



1. MECHANICAL DIMENSION

Product Dimension

Unit:mm	General Tolerance :	X.X : ± 0.38
		X.XX : ± 0.20

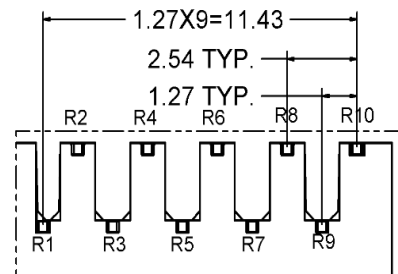
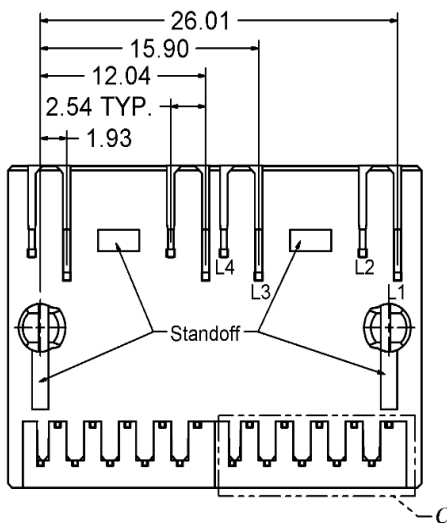
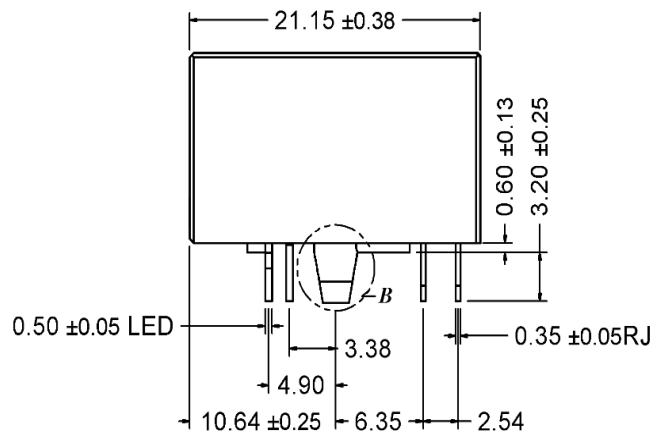
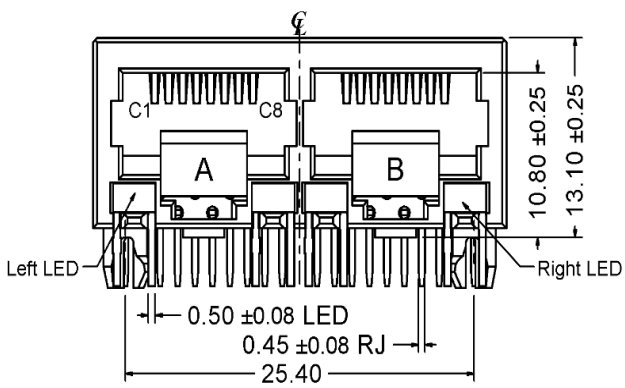
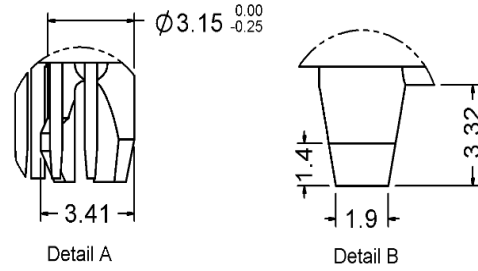
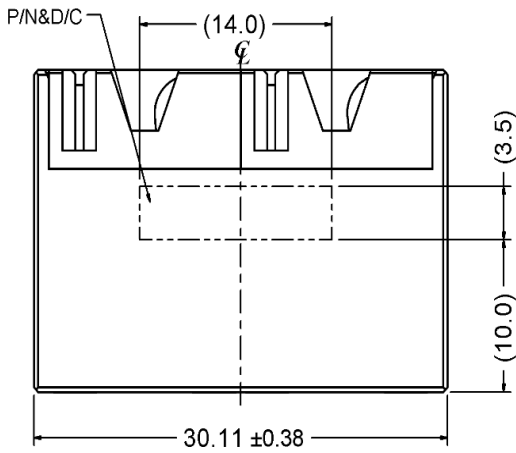

Detail C

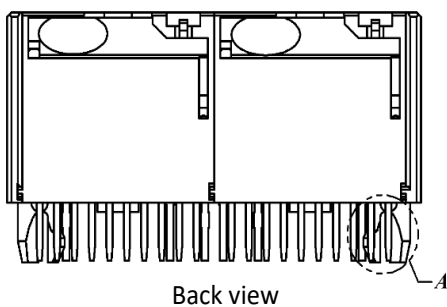

Back view

Recommended PCB Layout. Component side of board

All dimension units are "mm".

All dimension tolerances are  $\pm 0.05\text{mm}$  unless otherwise specified.

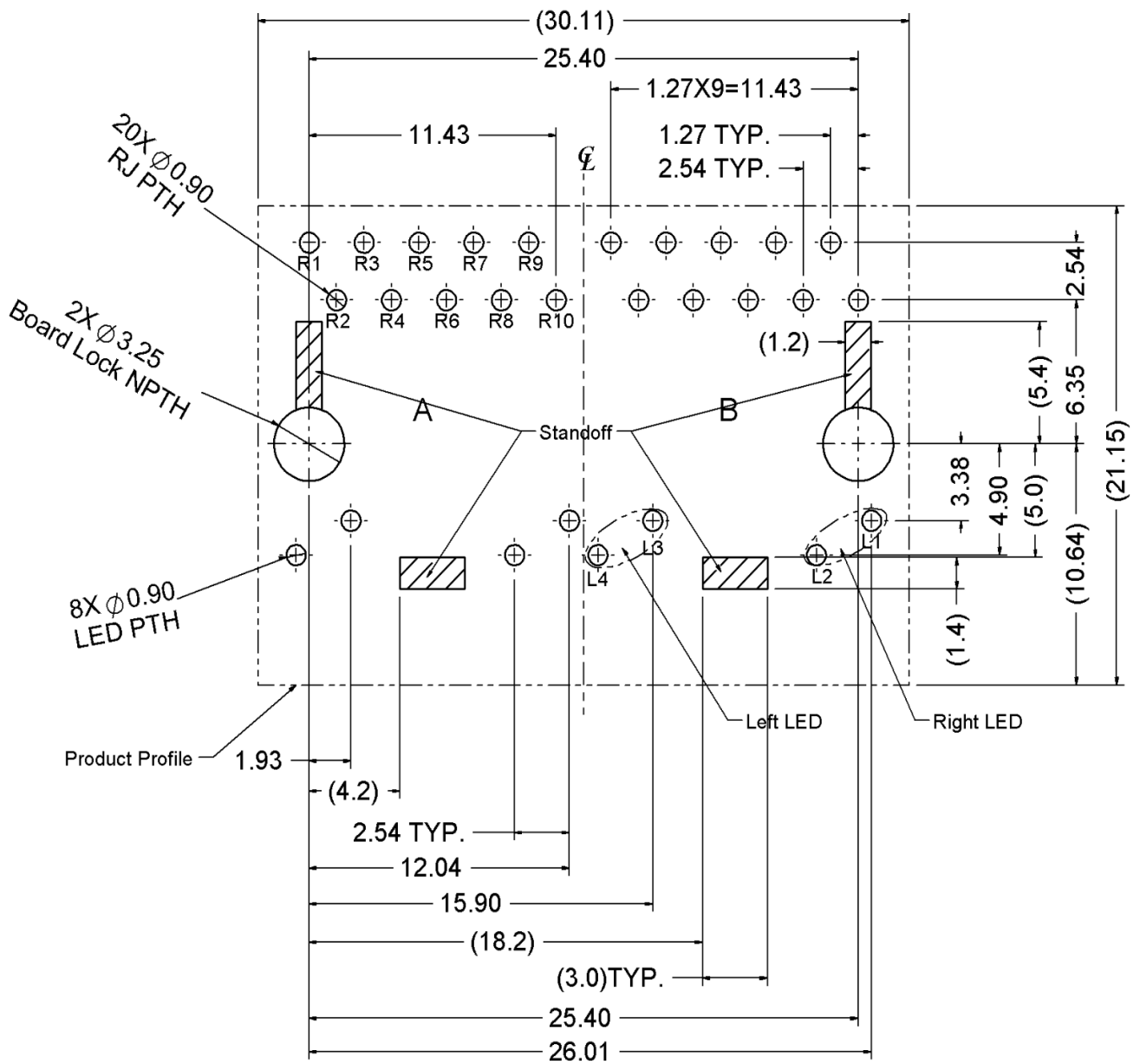

## Recommended Panel cutout

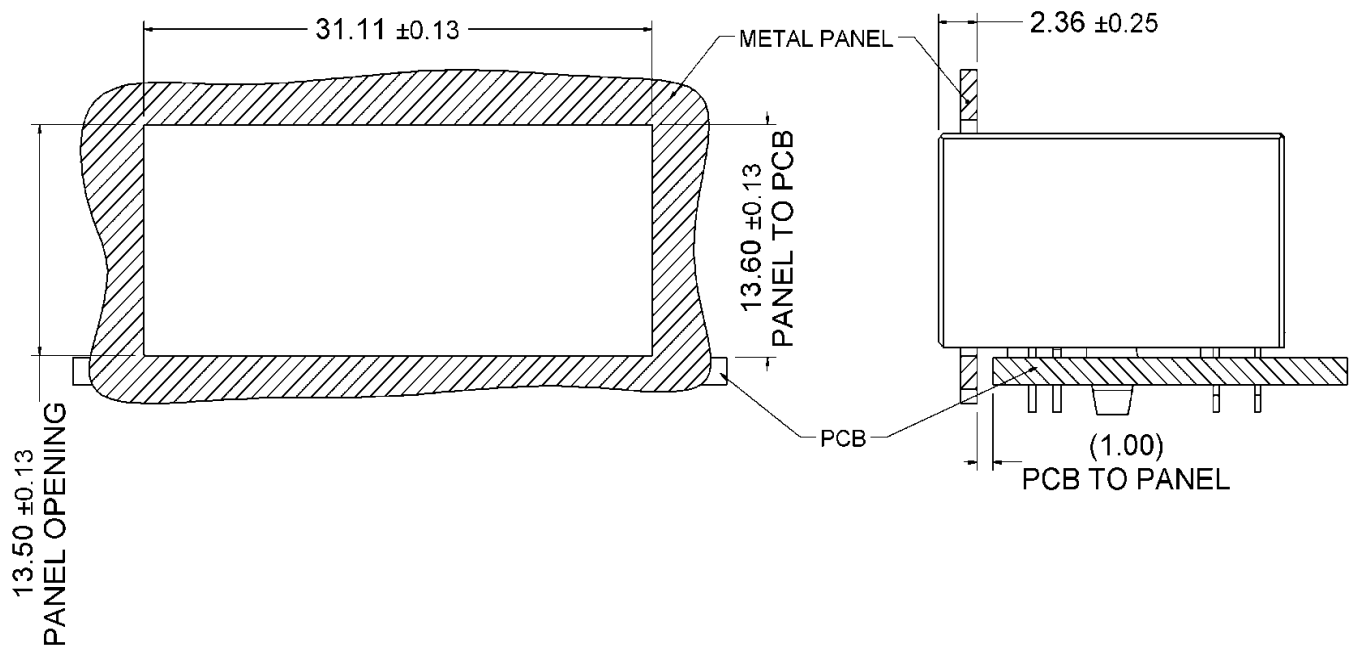

## 2. Packing Information

30 pcs finished goods per tray

7 trays(210 pcs finished goods) per inner box

4 Inner boxes(840 pcs finished goods) per master carton

### 3. Standard RJ45 Plug Specification

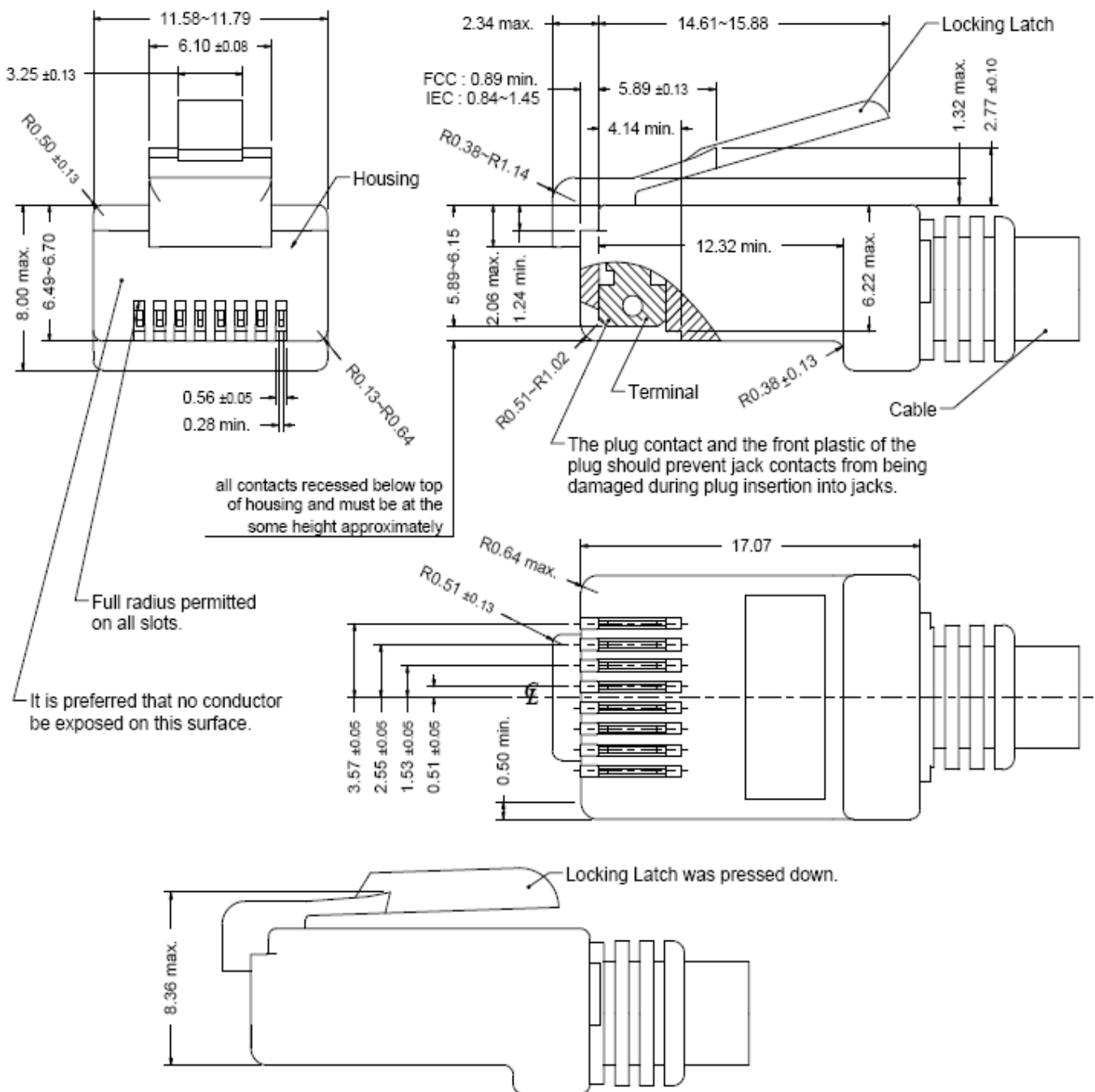

- All dimensions follow :  
FCC subpart F, 68,500, Figure (C)(2)(i) & (C)(2)(ii) & (C)(3)(i)  
IEC 60603-7
- All plugs must be meeting the requirements of plug Go & No-Go gauge.  
Gauge follow : FCC subpart F, 68,500, Figure (C)(4)(i) & (C)(5)(i)
- There must be no damage to Housing and Locking Latch.
- There must be no nicks and cuts in cable.
- Durability : 750 cycles generally

#### 4. REQUIREMENTS

##### Design and Construction

Product shall be of design, construction and physical dimensions specified on applicable.

##### Material

Terminal Parts (Underplating : 50 $\mu$ " min. Nickel overall)

RJ Terminal : Phosphor Bronze, Thickness=0.30mm

Finish : Contact Area : Gold Flash

Input Terminal : Brass, Thickness=0.35mm

Finish : 100 $\mu$ " min. Bright Tin

Case Terminal : Brass, Thickness=0.30mm

Finish : 100 $\mu$ " min. Bright Tin

Plastic Parts <UL94V-0>

Housing : PA6T, Black

Case : PA6T, Black

## 5. Operating and Storage Temperature

Operating Temperature : 0°C to +70°C

Storage Temperature : -40°C to +85°C

## 6. RJ45 specifications

Insulation Resistance : 500MΩ min.

Insertion force with the latch depressed : 20N max.

Removal force with the latch depressed : 20N max.

Locking Force of Plug Latch : 50N min. @ 60+/-5 sec.

Durability : 750 cycles

## 7. Performance and Test Description

Product is designed to meet electrical, mechanical and environmental performance requirements specified in below table.

All tests are performed at ambient environmental conditions per MIL-STD-1344A and EIA-364 unless otherwise specified.

## 8. Packaging and Packing

All parts shall be packaged and packed to protect against physical damage, corrosion and deterioration during shipment and storage.



9. ELECTRICAL CHARACTERISTICS @25°C

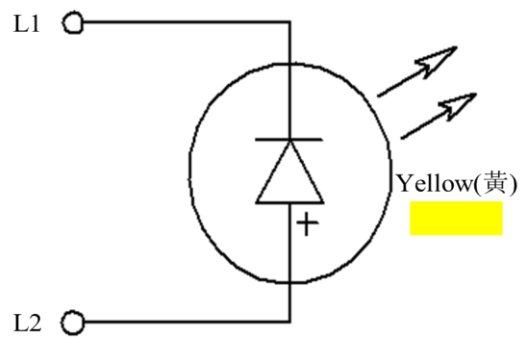
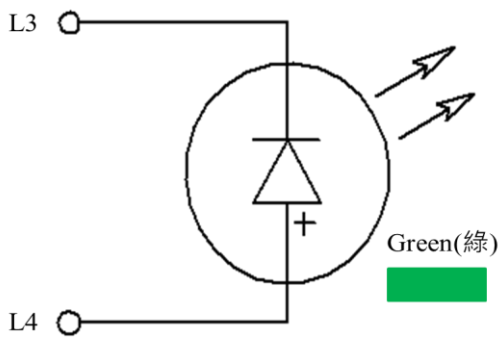
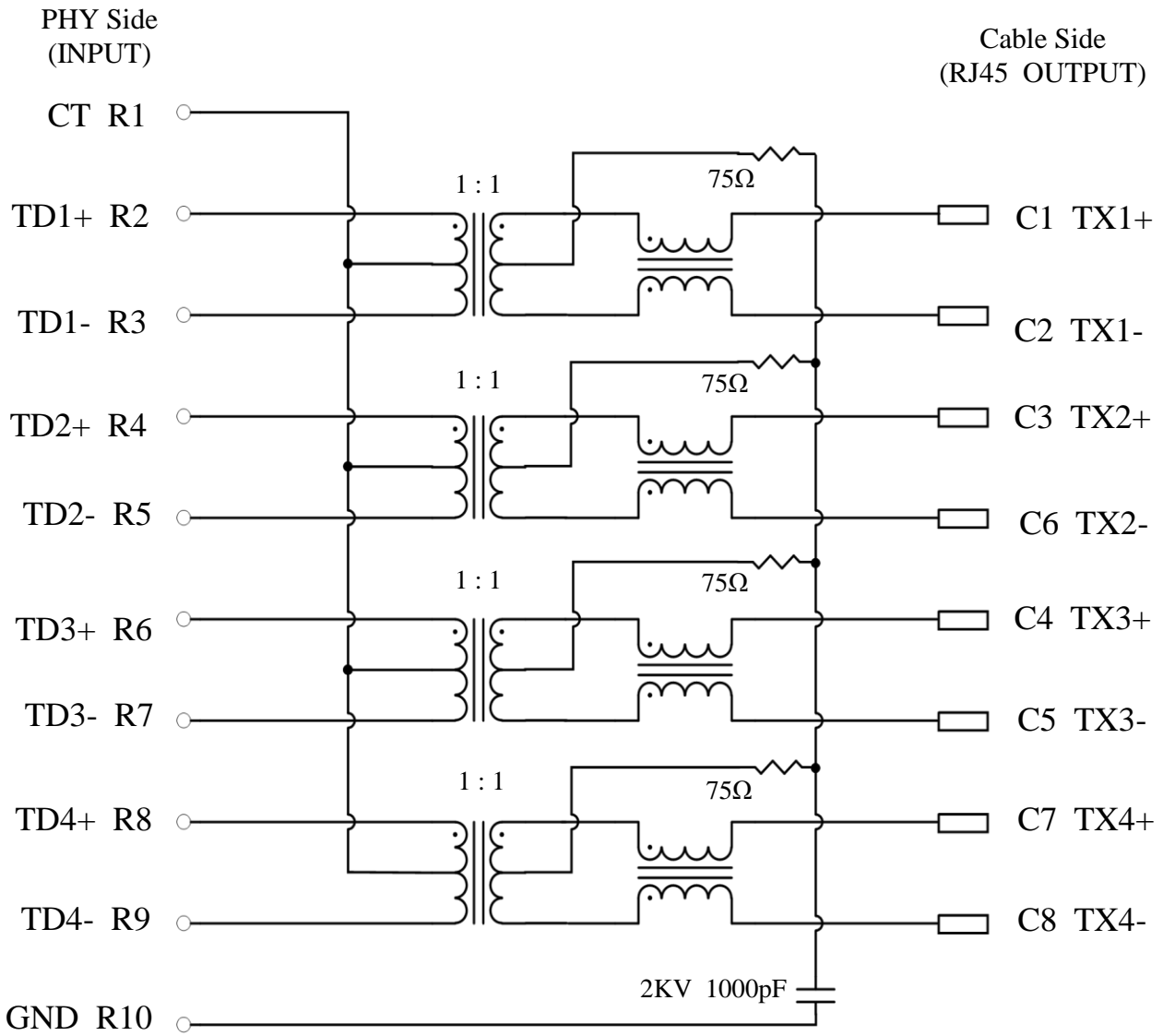

Emitting Color	$\lambda_p$ (nm)	$V_f$ @ $I_f=20mA$	$I_r$ @ $V_r=5V$
Green	570	1.7 ~2.6 V	10 $\mu$ A max.
Yellow	588	1.7 ~2.6 V	10 $\mu$ A max.

## Transmitter filter &amp; Receiver filter

Type : Balance low pass 100Ω impedance

Insertion loss : 1~100MHz -1.0dB max.

Return loss :	1~30MHz	-18dB min.	load 100Ω
	30~60MHz	-16dB min.	load 100Ω
	60~80MHz	-12dB min.	load 100Ω
	80~100MHz	-10dB min.	load 100Ω

## Common Mode Rejection

@1~100 MHz -30dB min.

## Cross Talk

@ 1~100MHz -30dB min.

## Inductance (OCL) @ 100KHz, 0.1V, 8mA DC BIAS

Input(TD1+,TD1-); (TD2+,TD2-); (TD3+,TD3-); (TD4+,TD4-) : 350 μH min.

## HiPot Test

PHY Side(input) To Cable Side(output) : 1500Vac 60s or 2250Vdc 60s

### 10. WAVE SOLDERING TEMPERATURE PROFILE

Note :

The measuring point for the specified temperature shall be on the soldered part of the lead.

