

# APPROVAL SHEET

To :

Customer P/N :

SINGATRON P/N : 2TJRH2-AD-0003

Description : USB 3.2 Gen 2 Over RJ45

Through Hole

2.5G Base-T

Contact Area : 30 $\mu$ " Min. Gold

LED :L-Green/Yellow; R-Green/Yellow



Spec No.  
RH223004-00

Update Date  
2023/7/18

Revision  
A

Approved	Checked	Prepared

**SINGATRON ENTERPRISE CO., LTD.**  
13925 Magnolia Avenue, Chino, CA 91710, U.S.A.



1. MECHANICAL DIMENSION

Product Dimension

Unit:mm	General Tolerance :	X.X : ± 0.38
		X.XX : ± 0.20

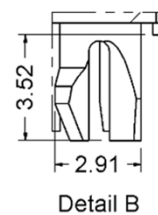
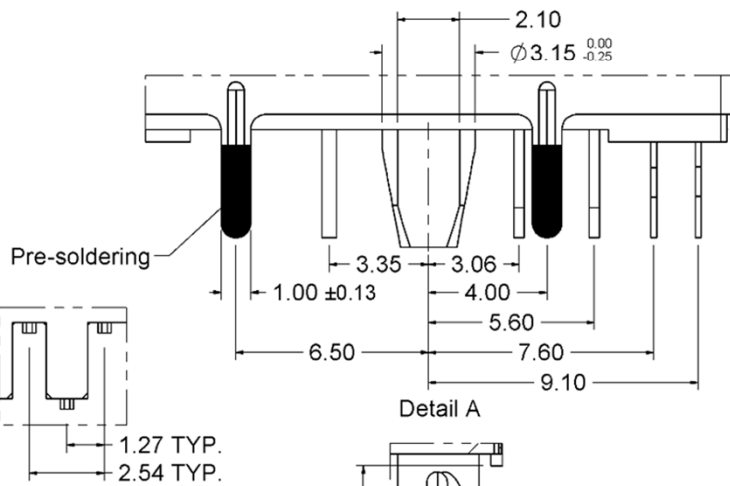
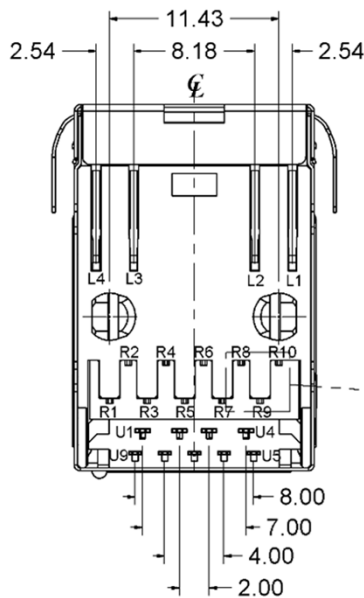
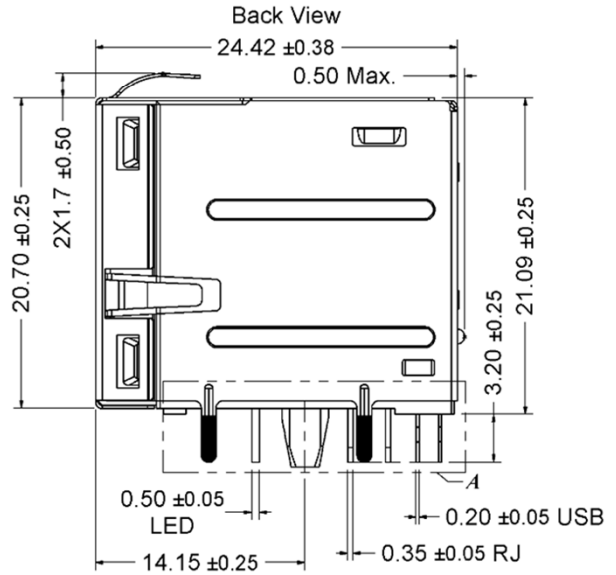
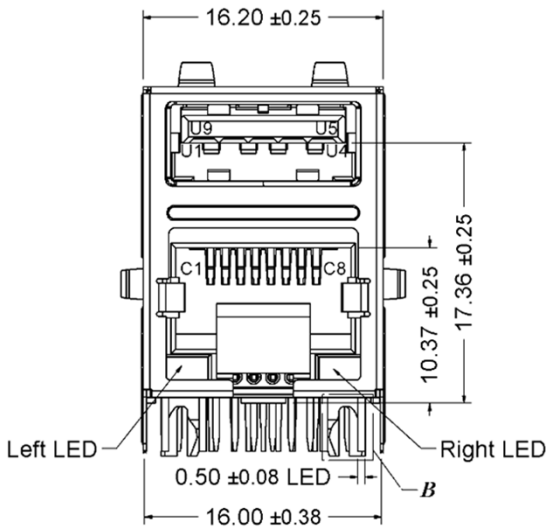
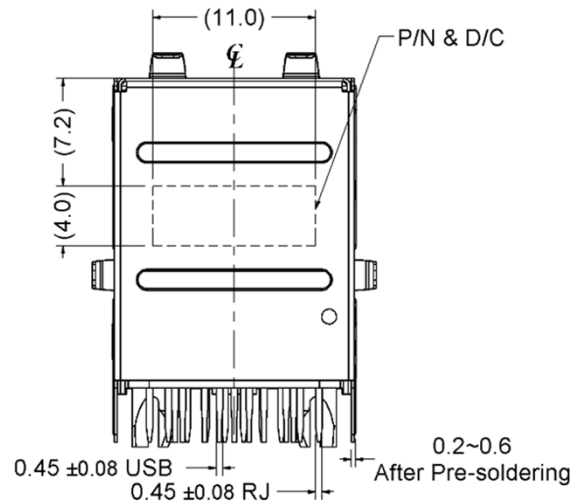
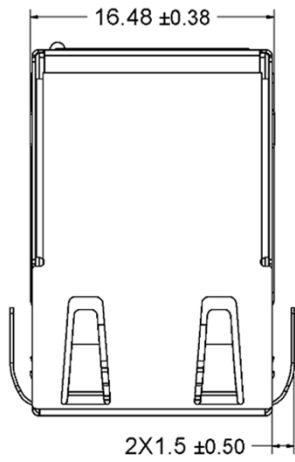

Recommended PCB Layout. Component side of board

All dimension units are "mm".

All dimension tolerances are ±0.05mm unless otherwise specified.

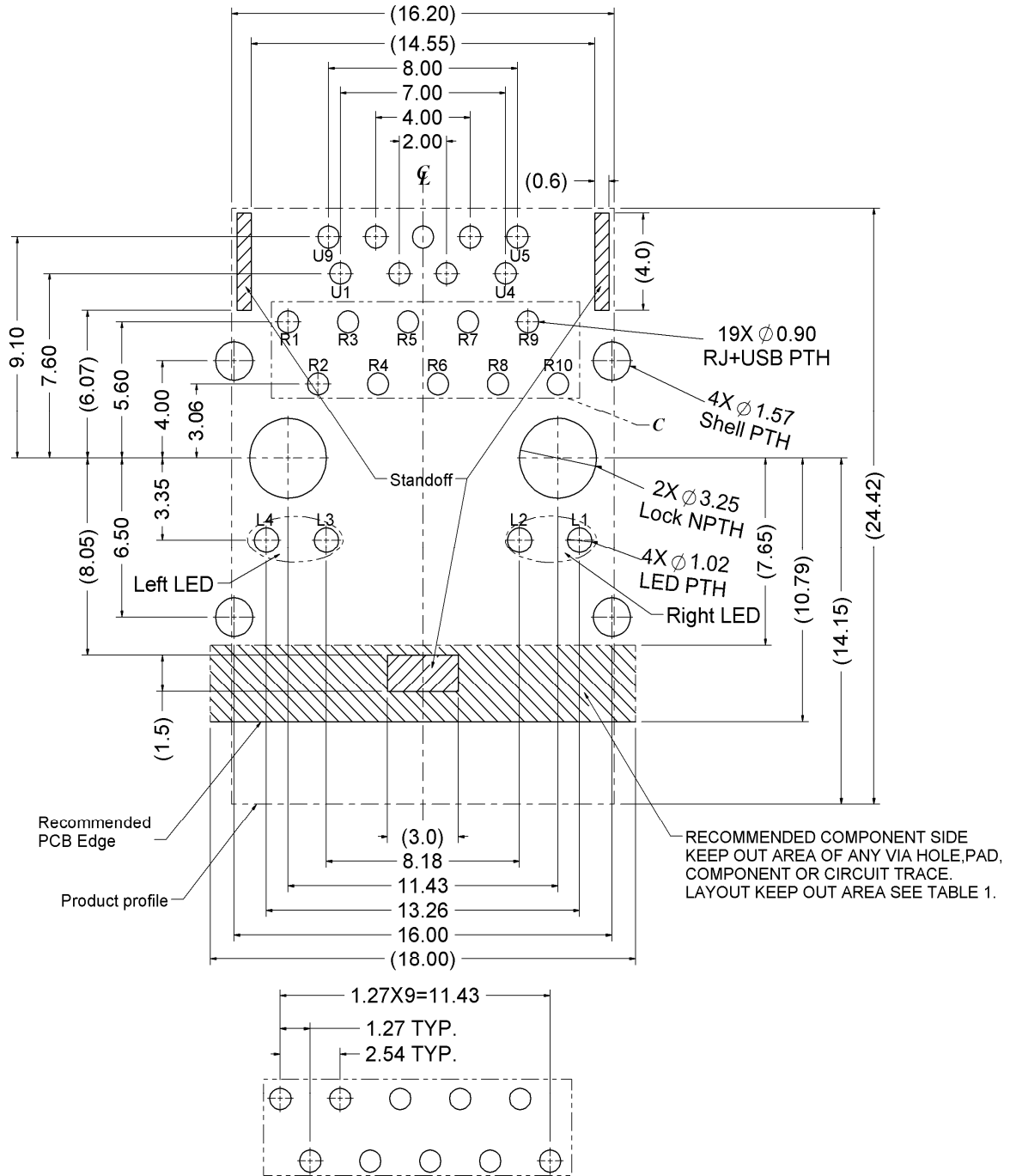
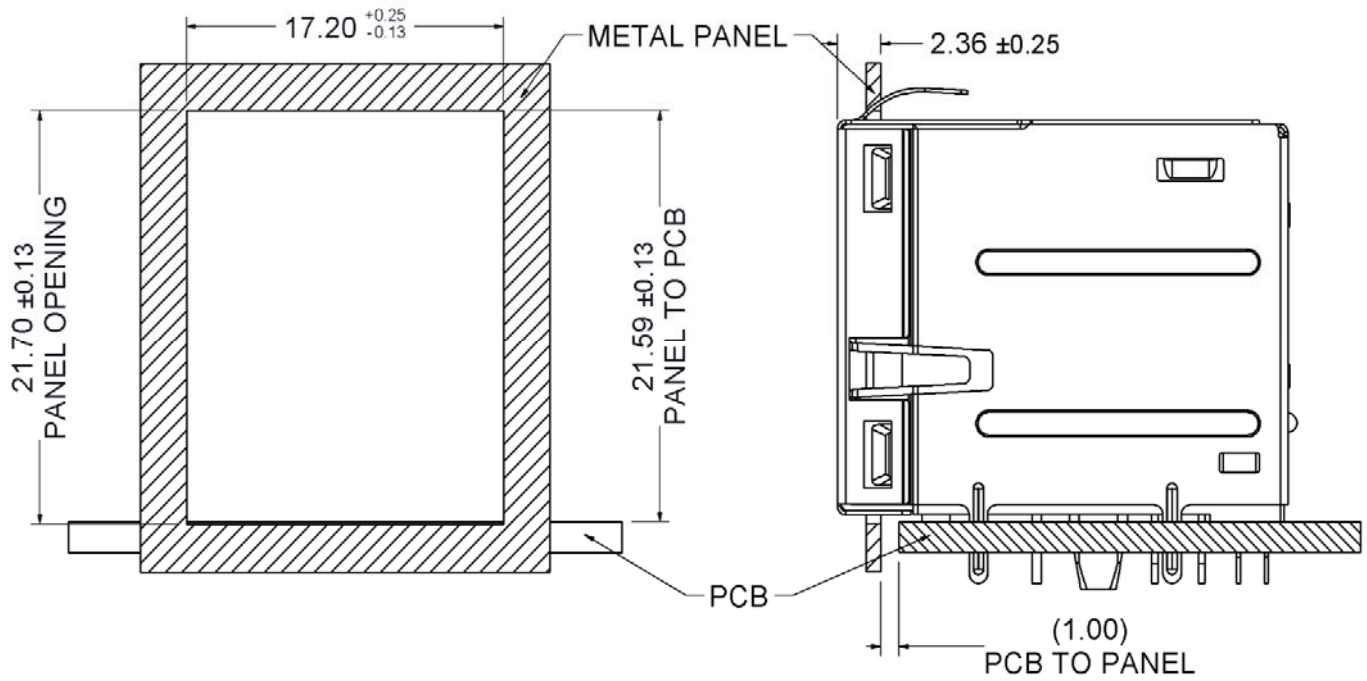

Table1

Layout Layer	Trace	component	Grounding	Test Point	Via Hole	PTH	NPTH
Component side	X	X	O	X	X	X	O
Inner layer	O	NA	O	NA	O	X	O
Bottom side	O	O	O	O	O	X	O

X--Forbid; O--OK; NA--Not Applicable.

## Recommended Panel cutout



## 2. Packing Information

50 pcs finished goods per tray

5 trays(250 pcs finished goods) per inner box

4 Inner boxes(1000 pcs finished goods) per master carton



4. USB 3.2 Standard-A Plug Specification

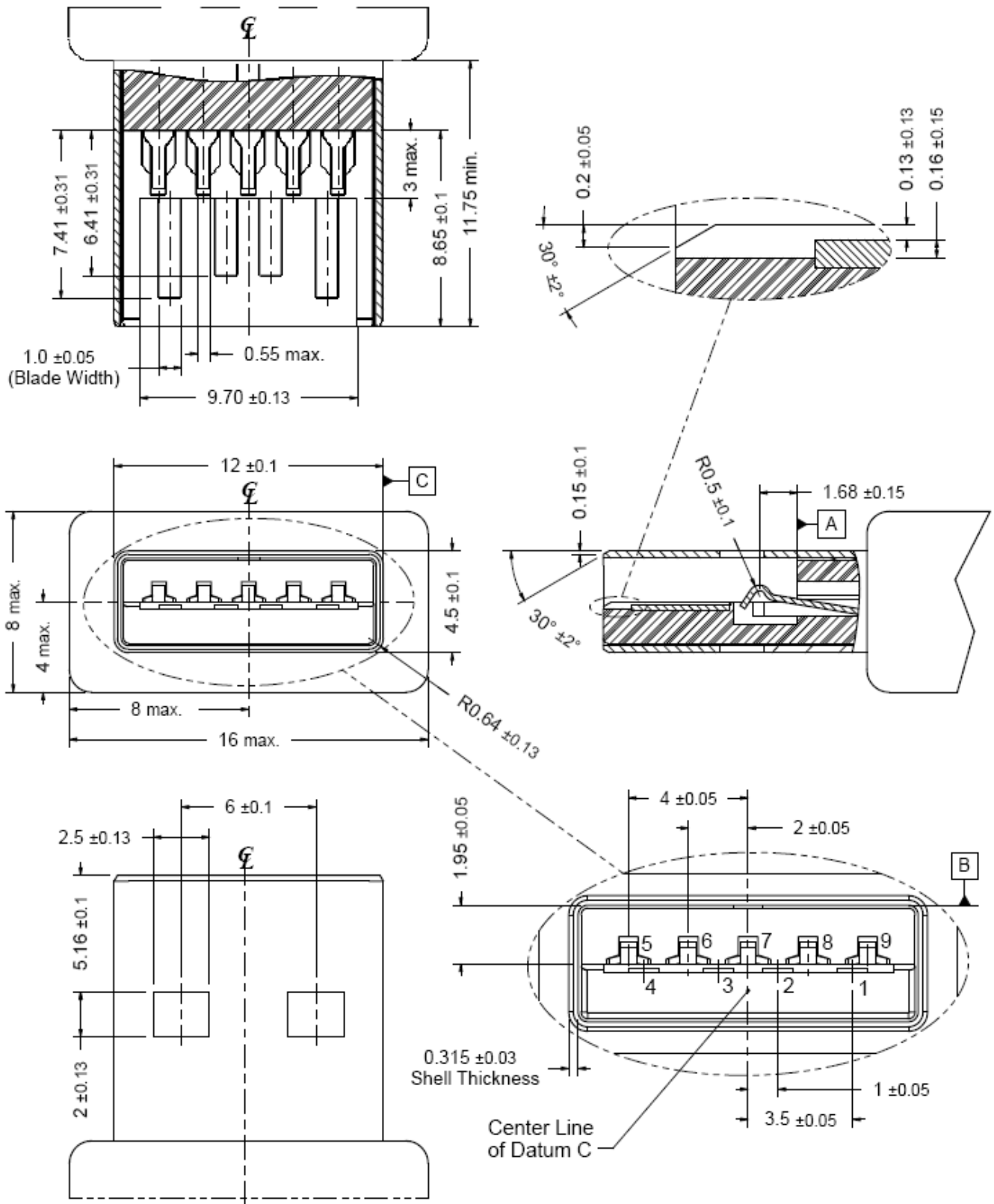

- All dimensions follow : Universal Serial Bus 3.0 Specification, Revision 1.0.

Figure 5-2. USB 3.1 Standard Plug-A interface dimensions

- Non-dimensions geometry for reference only, subject to change.

- Drawing for mating interface dimensions only.

## 5. REQUIREMENTS

### Design and Construction

Product shall be of design, construction and physical dimensions specified on applicable.

### Material

Terminal Parts ( Terminal : Underplating :50 $\mu$ " min. Nickel overall )

RJ Terminal : Phosphor Bronze, Thickness=0.30mm

Finish : Contact Area : 30 $\mu$ " Min Gold

Solder Tail : 100 $\mu$ " min. Matte Tin

USB 2.0&USB 3.2 Gen 2 Terminal : Brass, Thickness=0.20mm

Finish : Contact Area : 30 $\mu$ " Min Gold

Solder Tail : 100 $\mu$ " min. Matte Tin

Input Terminal : Brass, Thickness=0.35mm

Finish : 100 $\mu$ " min. Matte Tin

Module Terminal : Brass, Thickness=0.30mm

Finish : 100 $\mu$ " min. Matte Tin

Plastic Parts <UL94V-0>

Housing : PA6T, Black

Case : PA6T, Black

USB Housing : PA9T,Blue (300C)

USB Holder : PA9T, Black

Shield Parts

Front Shield : Stainless steel, Thickness=0.20mm, unplating

Back Shield : Stainless steel, Thickness=0.20mm, Pre-soldering

USB Shield :Stainless steel, Thickness=0.25mm



## 6. Operating and Storage Temperature

Operating Temperature : 0°C to +70°C

Storage Temperature : -40°C to +85°C

## 7. RJ45 specifications

Insulation Resistance : 500MΩ min.

Insertion force with the latch depressed : 20N max.

Removal force with the latch depressed : 20N max.

Locking Force of Plug Latch : 50N min. @ 60+/-5 sec.

Durability : 2500 cycles

## 8. USB 3.2 Gen2 specifications

Insulation Resistance : 100MΩ min.

Dielectric Withstanding Voltage : 100VAC @1min

Insertion force : 35N max

Removal force : The connector extraction force shall not be less than 10N initial  
and 8N after the specified insertion/extraction or durability cycles

Durability : 1500 cycles

## 9. Performance and Test Description

Product is designed to meet electrical, mechanical and environmental performance requirements specified in below table.

All tests are performed at ambient environmental conditions per MIL-STD-1344A and EIA-364 unless otherwise specified.

## 10 Packaging and Packing

All parts shall be packaged and packed to protect against physical damage, corrosion and deterioration during shipment and storage.

## 11. USB 3.2 GEN 2 Standard-A Schematic



## USB 3.2 GEN 2 Standard-A connector Pin Assignment

Pin Number	Signal Name	Description	Mating Sequence
U1	VBUS	Power	Second
U2	D-	USB 2.0 Differential pair	Third
U3	D+		
U4	GND	Ground for power return	Second
U5	StdA_SSRX-	Super speed receiver differential pair	Last
U6	StdA_SSRX+		
U7	GND_DRAIN	Ground for Signal return	
U8	StdA_SSTX-	Surper speed transmitter differential pair	
U9	StdA_SSTX+		
Shell	Shield	Connector metal shell	First

12. ELECTRICAL CHARACTERISTICS @25°C

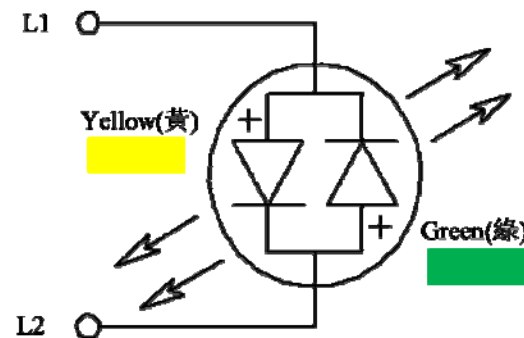
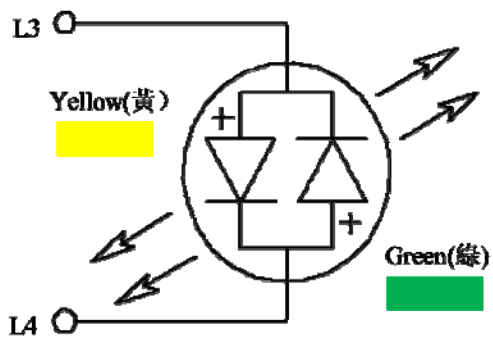
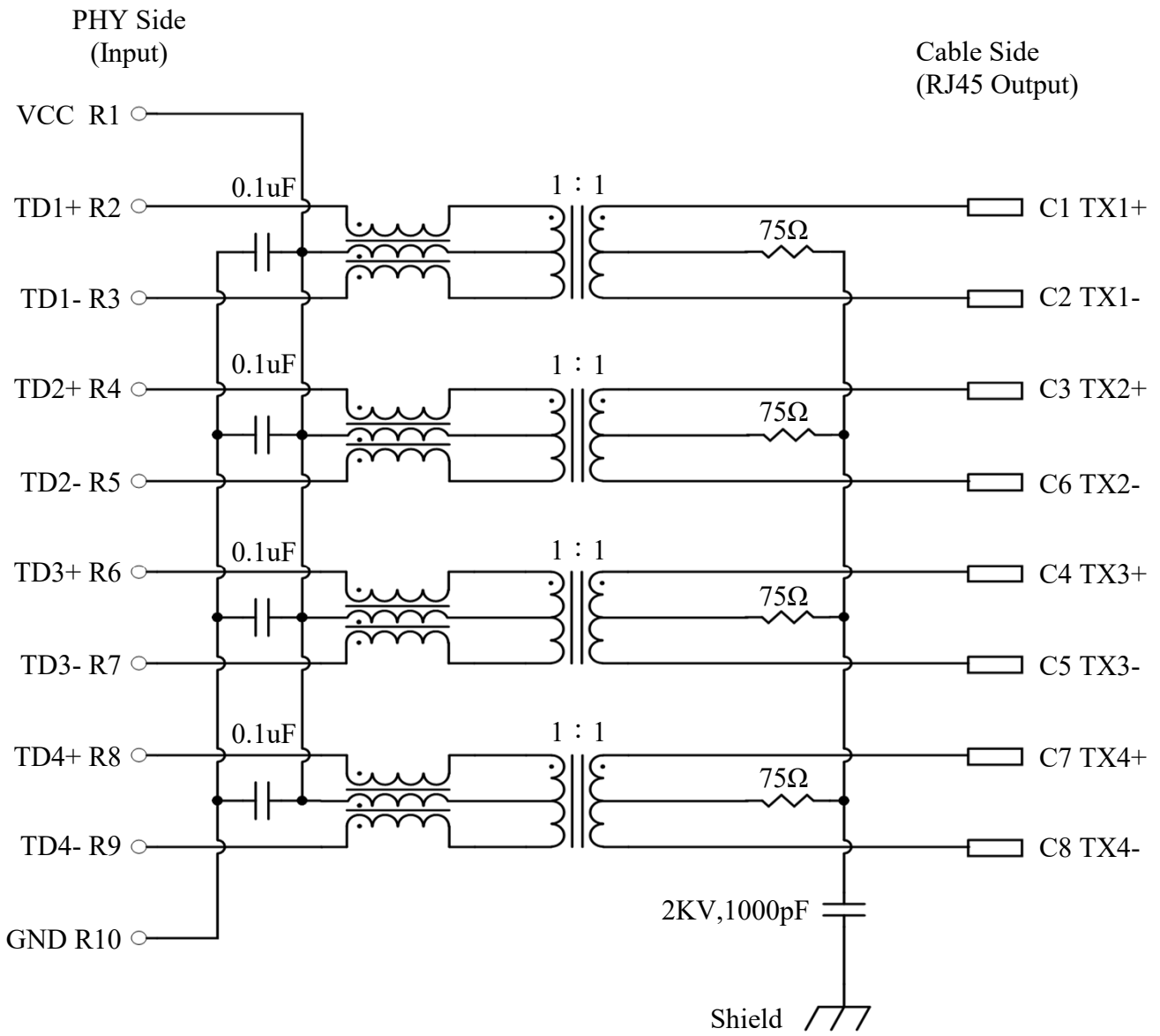

Emitting Color	$\lambda_p$ (nm)	$V_f @ I_f=20mA$	$I_r @ V_r=5V$
Green	570	1.7 ~2.6 V	10 $\mu$ A max.
Yellow	588	1.7 ~2.6 V	10 $\mu$ A max.

## Transmitter filter &amp; Receiver filter

Type : Balance low pass 100Ω impedance

Insertion loss : 1~50MHz -0.5dB max.

50~125MHz -1.0dB max.

125~200MHz -2.0dB max.

Return loss : 1~40MHz -20dB min. load 100Ω

40~200MHz  $-20+15*\log(\text{Freq MHz}/40\text{MHz})$  dB min. load 100Ω

## Reflected CM to Diff Conversion(REF)

1MHz -30dB min.

50MHz -30dB min.

100MHz -27dB min.

200MHz -24dB min.

## CM to DM Conversion(REF)

1-50MHZ -35 dB min

125MHZ -30 dB min

200MHZ -25 dB min

## Reflected Diff to CM Conversion(REF)

1-10MHZ -48 dB min

10-200MHz  $-48+19*\log(\text{Freq MHz}/10\text{MHz})$  dB min

## CM to CM Attenuation (REF)

1-200MHZ -25 dB min

## Cross Talk

1~40MHz -35dB min.

40~125MHz  $-35+15\log((\text{Freq MHz}/40\text{MHz}))$  dB min.

## Inductance (OCL) @ 100KHz, 0.1V, 8mA DC BIAS

Input(TD1+,TD1-); (TD2+,TD2-); (TD3+,TD3-); (TD4+,TD4-): 180 μH min.

## HiPot Test

PHY Side(input) To Cable Side(output): 1500Vac 60s or 2250Vdc 60s

## 13. WAVE SOLDERING TEMPERATURE PROFILE

Note :

The measuring point for the specified temperature shall be on the soldered part of the lead.

