

# APPROVAL SHEET

---

To :

Customer P/N :

Singatron P/N : 2TJRM5-AD-0001

Description : RJ45 multiport 2X4

Through Hole

10/100 Base-T

Contact Area : 30 $\mu$ " Min. Gold

LED : L-Yellow; R-Green

Light Pipe : Upper/Lower Port



Spec No.  
RM518046-00

Update Date  
10/31/2018

Revision  
A

Approved	Checked	Prepared

SINGATRON U.S.A.  
13925 MAGNOLIA AVE  
CHINO, CA 91710 USA



1. MECHANICAL DIMENSION

Product Dimension

Unit:mm	General Tolerance :	X.X : ± 0.38
		X.XX : ± 0.20

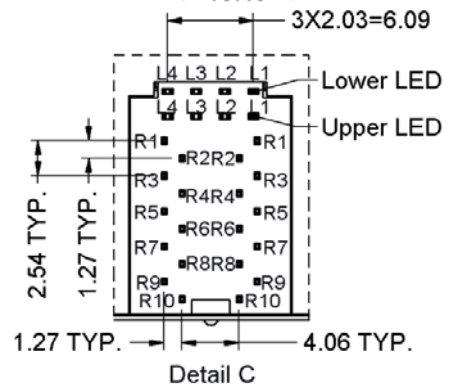
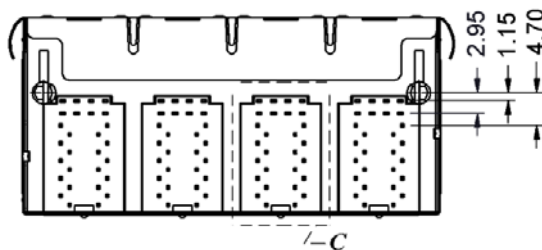
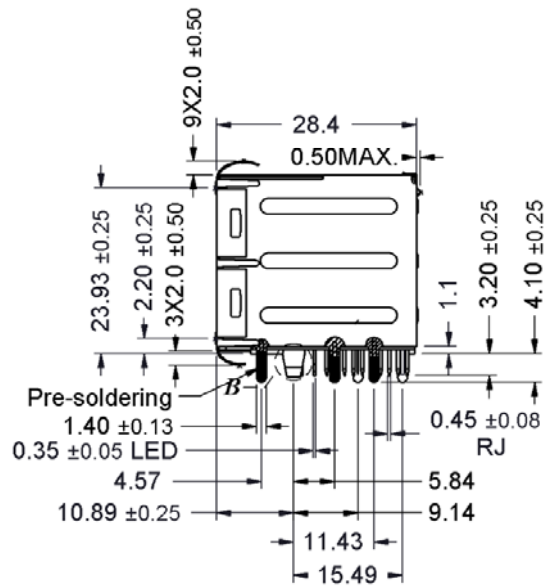
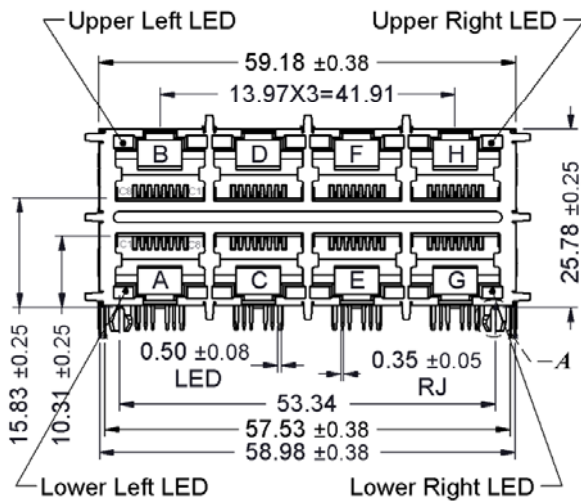
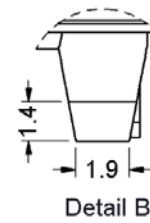
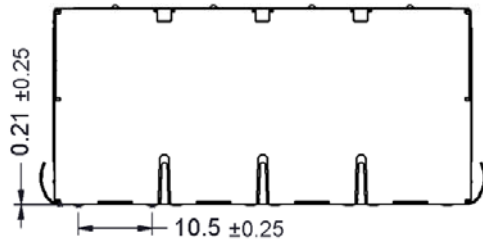
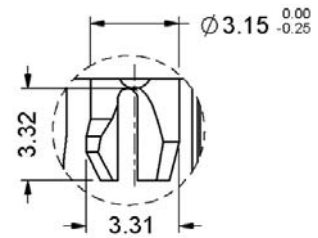
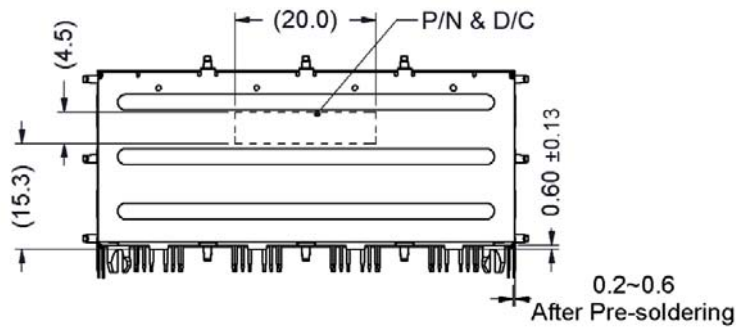

Recommended PCB Layout. Component side of board

All dimension units are "mm".

All dimension tolerances are ±0.05mm unless otherwise specified.

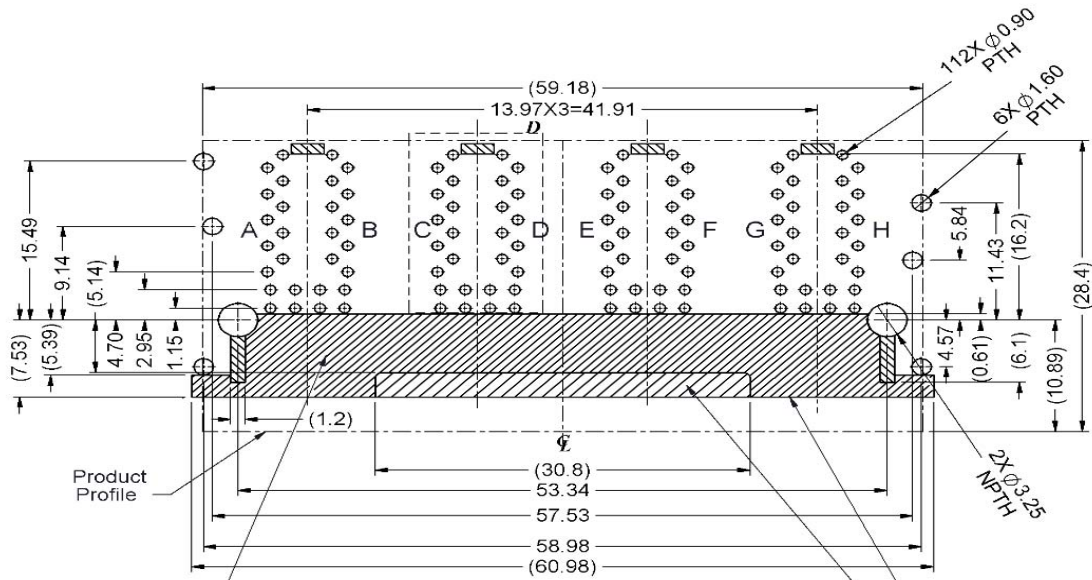

IF THE PART HAS BOTTOM SPRING FINGER, THIS IS THE PCB CUTOUT AREA. IF THE PART HAS NO BOTTOM SPRING FINGER THIS IS THE LAYOUT KEEPOUT AREA

RECOMMENDED COMPONENT SIDE KEEP OUT AREA OF ANY VIA HOLE, PAD, COMPONENT OR CIRCUIT TRACE. LAYOUT KEEPOUT AREA SEE TABLE 1.

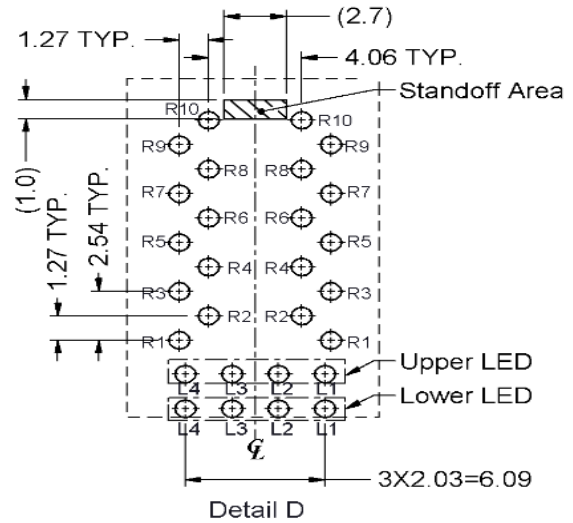
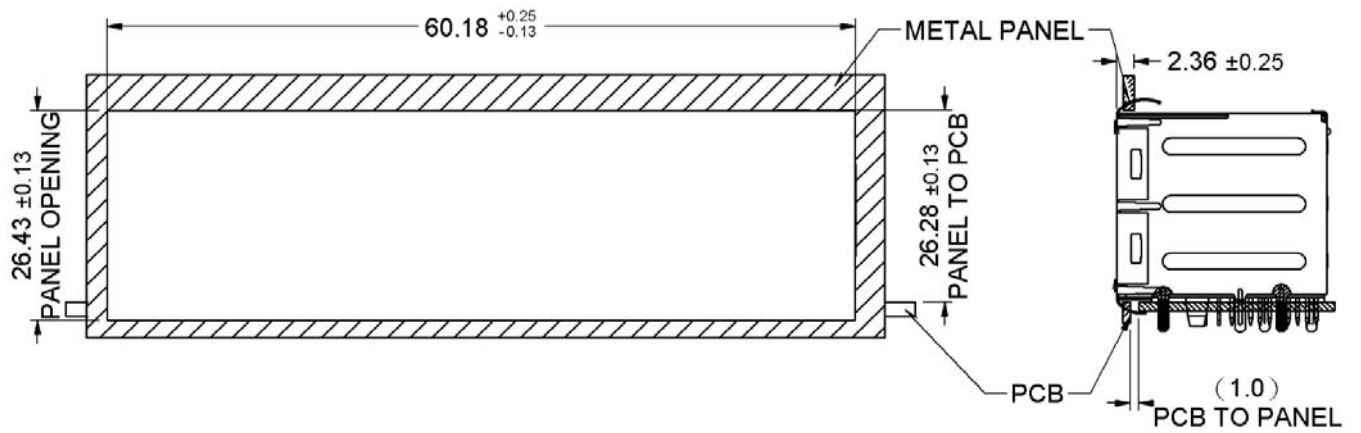

Table1

Layout Layer	Trace	component	Grounding	Test Point	Via Hole	PTH	NPTH
Component side	X	X	O	X	X	X	O
Inner layer	O	NA	O	NA	O	X	O
Bottom side	O	O	O	O	O	X	O

X--Forbid; O--OK; NA--Not Applicable.

Recommended Panel cutout



2. Packing Information

- 16 pcs finished goods per tray
- 5 trays(80 pcs finished goods) per inner box
- 4 Inner boxes(320 pcs finished goods) per master carton

### 3. Standard RJ45 Plug Specification

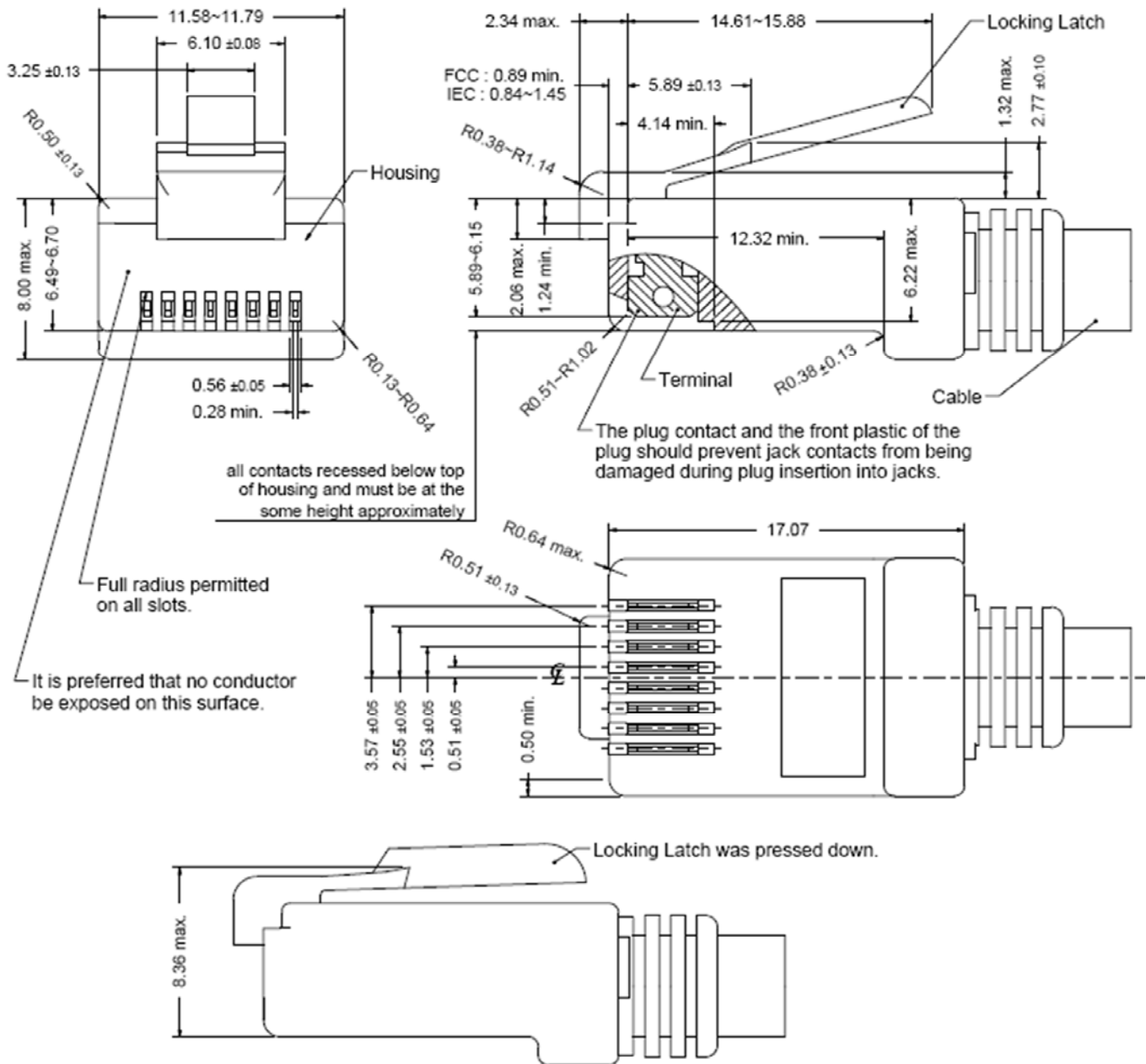

- All dimensions follow :  
FCC subpart F, 68,500, Figure (C)(2)(i) & (C)(2)(ii) & (C)(3)(i)  
IEC 60603-7
- All plugs must be meeting the requirements of plug Go & No-Go gauge.  
Gauge follow : FCC subpart F, 68,500, Figure (C)(4)(i) & (C)(5)(i)
- There must be no damage to Housing and Locking Latch.
- There must be no nicks and cuts in cable.
- Durability : 750 cycles generally

#### 4. REQUIREMENTS

##### Design and Construction

Product shall be of design, construction and physical dimensions specified on applicable.

##### Material

##### Terminal Parts (Underplating :50 $\mu$ " min. Nickel overall)

RJ Terminal : YCUT-FX-H, Thickness=0.30mm

Finish : Contact Area : 30 $\mu$ " min. Gold

Input Terminal : Brass, Thickness=0.35mm

Finish : 100 $\mu$ " min. Bright Tin

Case Terminal : Brass, Thickness=0.30mm

Finish : 100 $\mu$ " min. Bright Tin

##### Plastic Parts <UL94V-0>

Housing : PA6T, Black

Case : PA6T, Black

Spacer : PA6T, Black

Terminal Cover : PA6T, Black

Terminal Base : PA6T, Black

Insert : PA6T, Black

Light Pipe : PC, Transparent

##### Shield Parts

Front Shield : Stainless Steel, Thickness=0.20mm, unplating

Back Shield : Stainless Steel, Thickness=0.20mm, Pre-soldering

## 5. Operating and Storage Temperature

Operating Temperature : 0°C to +70°C

Storage Temperature : -40°C to +85°C

## 6. RJ45 specifications

Insulation Resistance : 500MΩ min.

Insertion force with the latch depressed : 20N max.

Removal force with the latch depressed : 20N max.

Locking Force of Plug Latch : 50N min. @ 60+/-5 sec.

Durability : 2500 cycles

## 7. Performance and Test Description

Product is designed to meet electrical, mechanical and environmental performance requirements specified in below table.

All tests are performed at ambient environmental conditions per MIL-STD-1344A and EIA-364 unless otherwise specified.

## 8. Packaging and Packing

All parts shall be packaged and packed to protect against physical damage, corrosion and deterioration during shipment and storage.



9. ELECTRICAL CHARACTERISTICS @25°C

PHY Side  
(Input)

Cable Side  
(RJ45 Output)

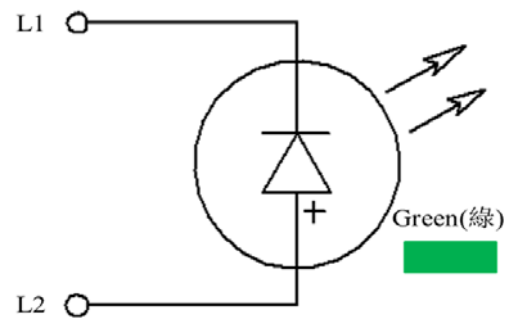
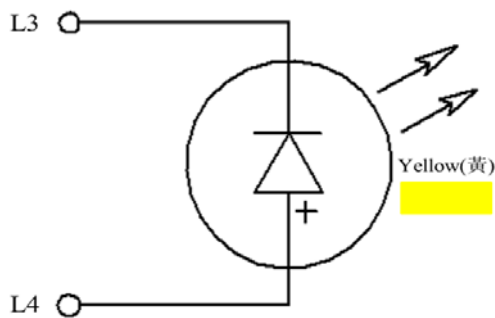
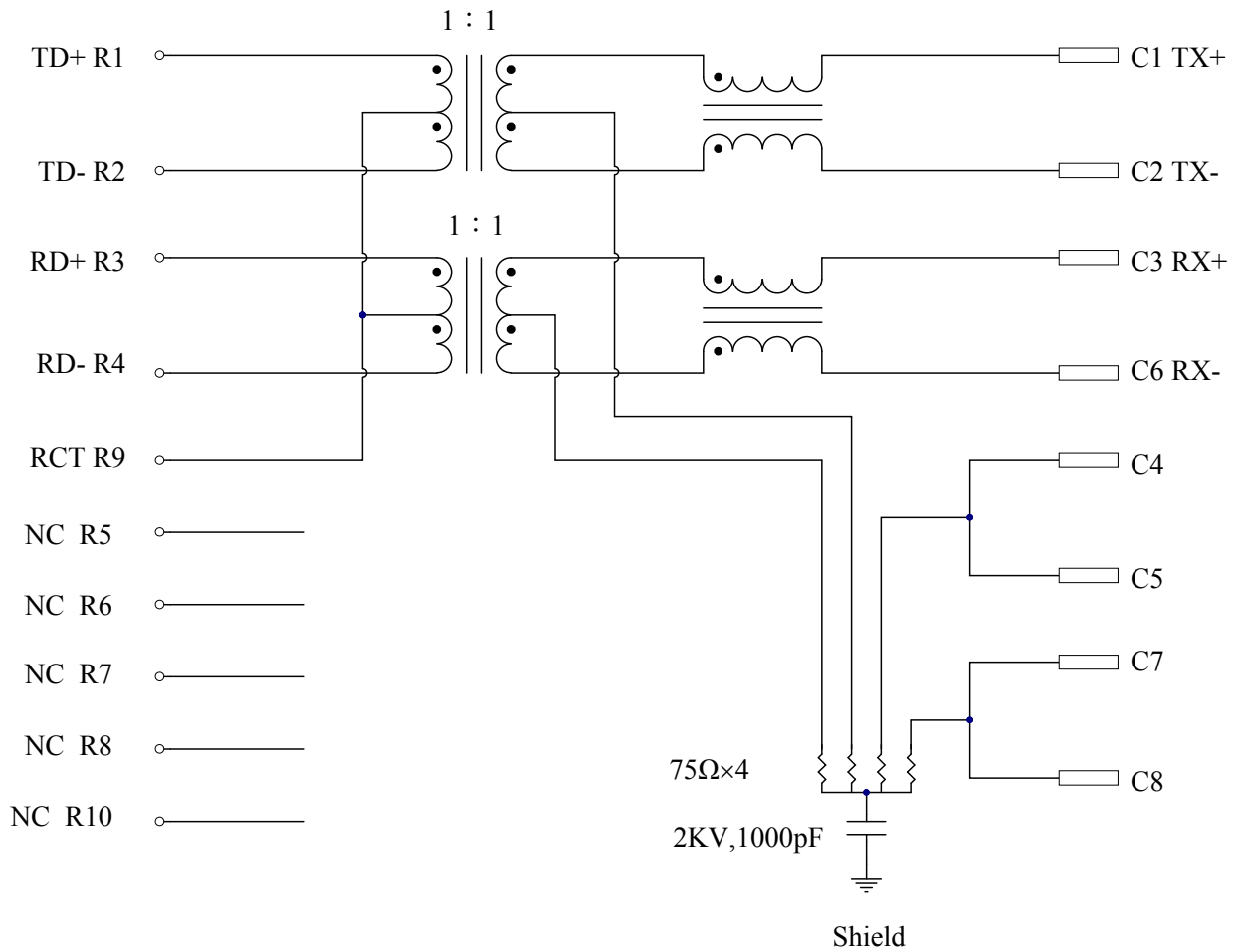

Emitting Color	$\lambda_p$ (nm)	$V_f @ I_f=20mA$	$I_r @ V_r=5V$
Yellow	588	1.7 ~2.6 V	10 $\mu$ A max.
Green	570	1.7 ~2.6 V	10 $\mu$ A max.

## Transmitter filter &amp; Receiver filter

Type : Balance low pass 100Ω impedance

Insertion loss : 1~100MHz -1.0dB Max.

Return loss :	1~30MHz	-18dB Min.	load 100Ω
	30~60MHz	-16dB Min.	load 100Ω
	60~80MHz	-12dB Min.	load 100Ω

## Common Mode Rejection

@1~100 MHz -30dB Min.

## Cross Talk

@ 1~100MHz -30dB Min.

Inductance (OCL) @ 100KHz, 0.1V, 8mA DC BIAS

Input(TD+, TD-); (RD+, RD-) : 350 μH Min.

## HiPot Test

PHY Side(Input) To Cable Side(Output) : 1500Vac 60s or 2250Vdc 60s

### 10. WAVE SOLDERING TEMPERATURE PROFILE

Note :

The measuring point for the specified temperature shall be on the soldered part of the lead.

