

APPROVAL SHEET

To :

Customer P/N :

Singatron P/N : 2TJRM5-ZZ-0012

Description : RJ45 multiport 2X4
Through Hole
10/100/1000 Base-T
Contact Area : 30 μ " min.Gold
LED : L-Green;R-Green/Yellow



Spec No.	Update Date	Revision
RM516025-00	2016/11/22	A

Approved	Checked	Prepared

SINGATRON U.S.A.
13925 MAGNOLIA AVE
CHINO, CA 91710 USA

1. MECHANICAL DIMENSION

1.1 Product Dimension

Unit : mm	General Tolerance :	X.X : ± 0.38
		X.XX : ± 0.20

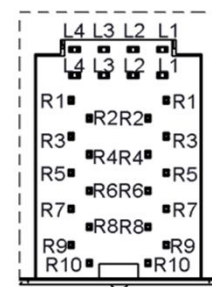
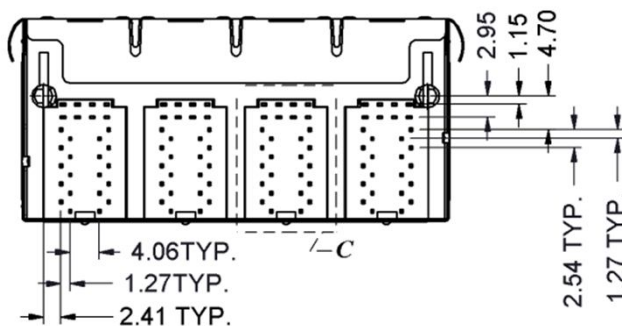
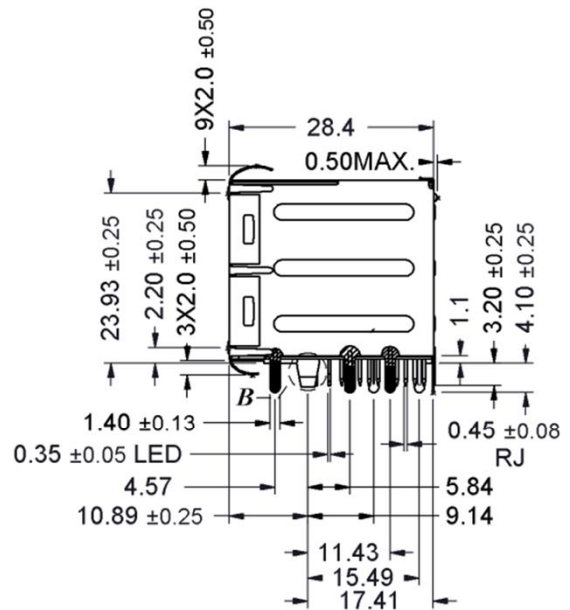
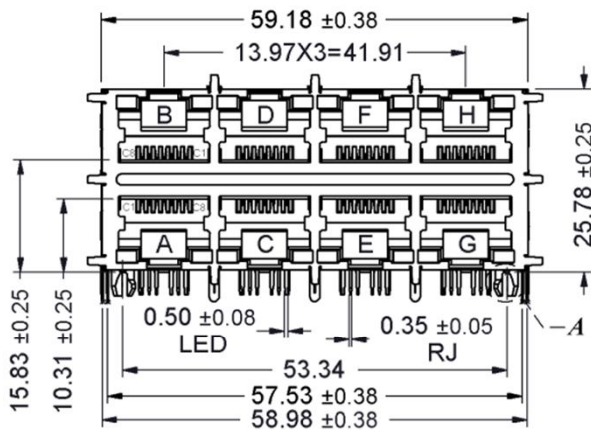
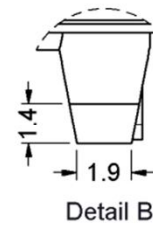
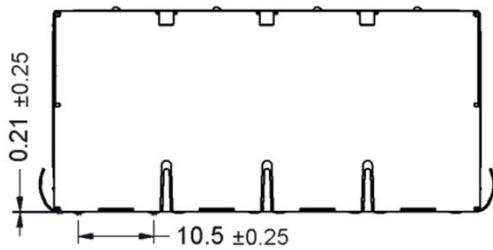
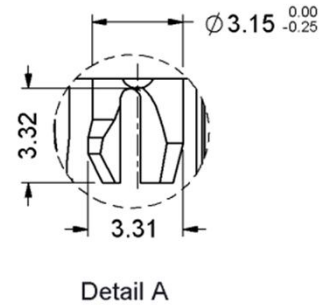
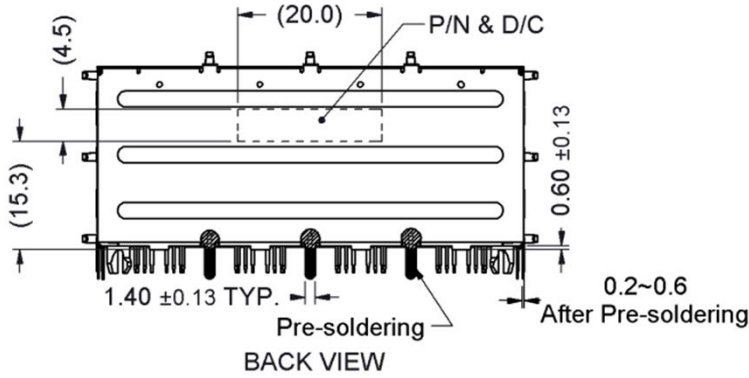

1.2 Recommended PCB Layout

Component Side of Board

All dimension tolerances are $\pm 0.05\text{mm}$ unless otherwise specified

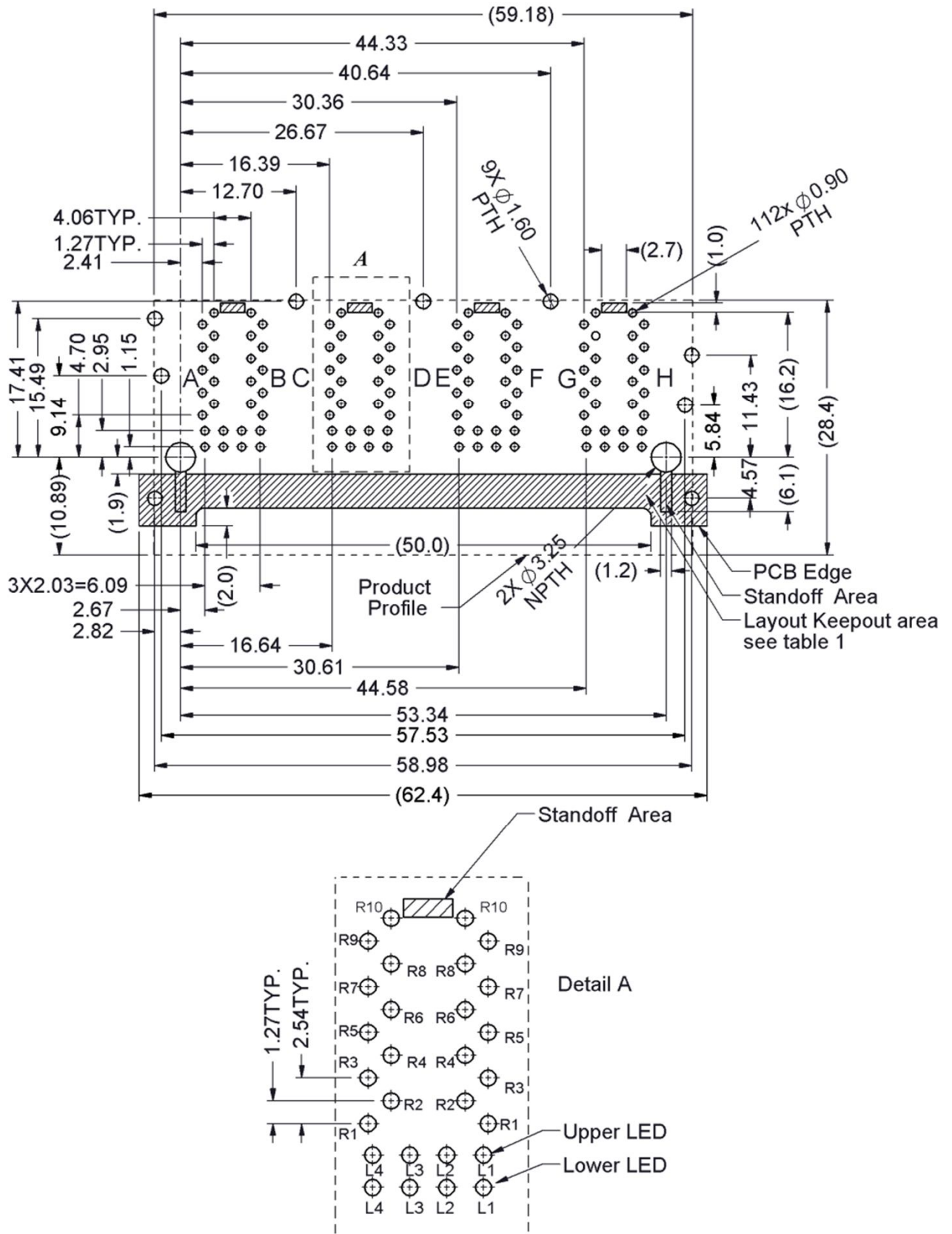
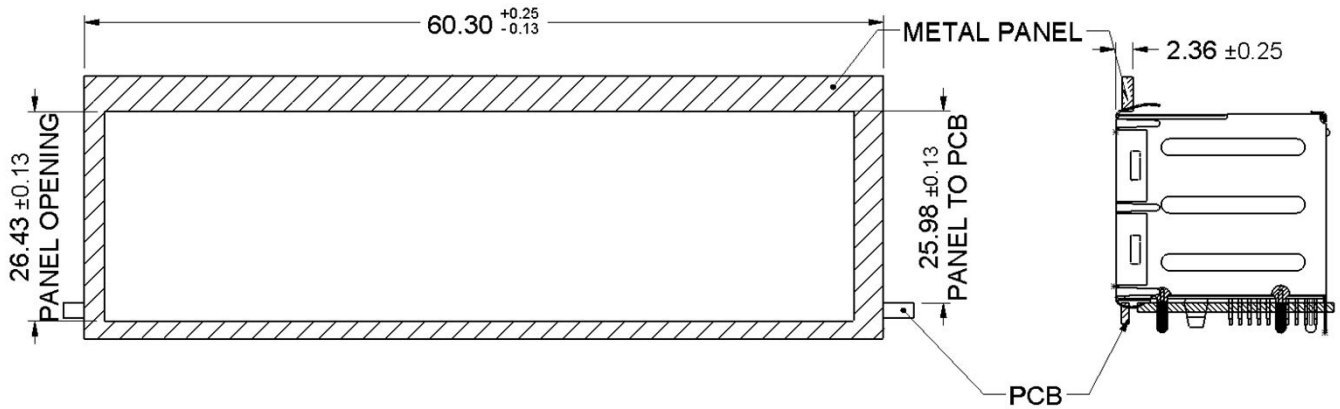

Table1

Layout Layer	Trace	compo- nent	Groun- ding	Test Point	Via Hole	PTH	NPTH
Component side	X	X	O	X	X	X	O
Inner layer	O	NA	O	NA	O	X	O
Bottom side	O	O	O	O	O	X	O

X--Forbid; O--OK; NA--Not Applicable.

1.3 Recommended Panel cutout



1.4 Packing Information

16 pcs finished goods per tray

5 trays(80 pcs finished goods) per inner box

4 Inner boxes(320 pcs finished goods) per master carton

1.5 Standard RJ45 Plug Specification

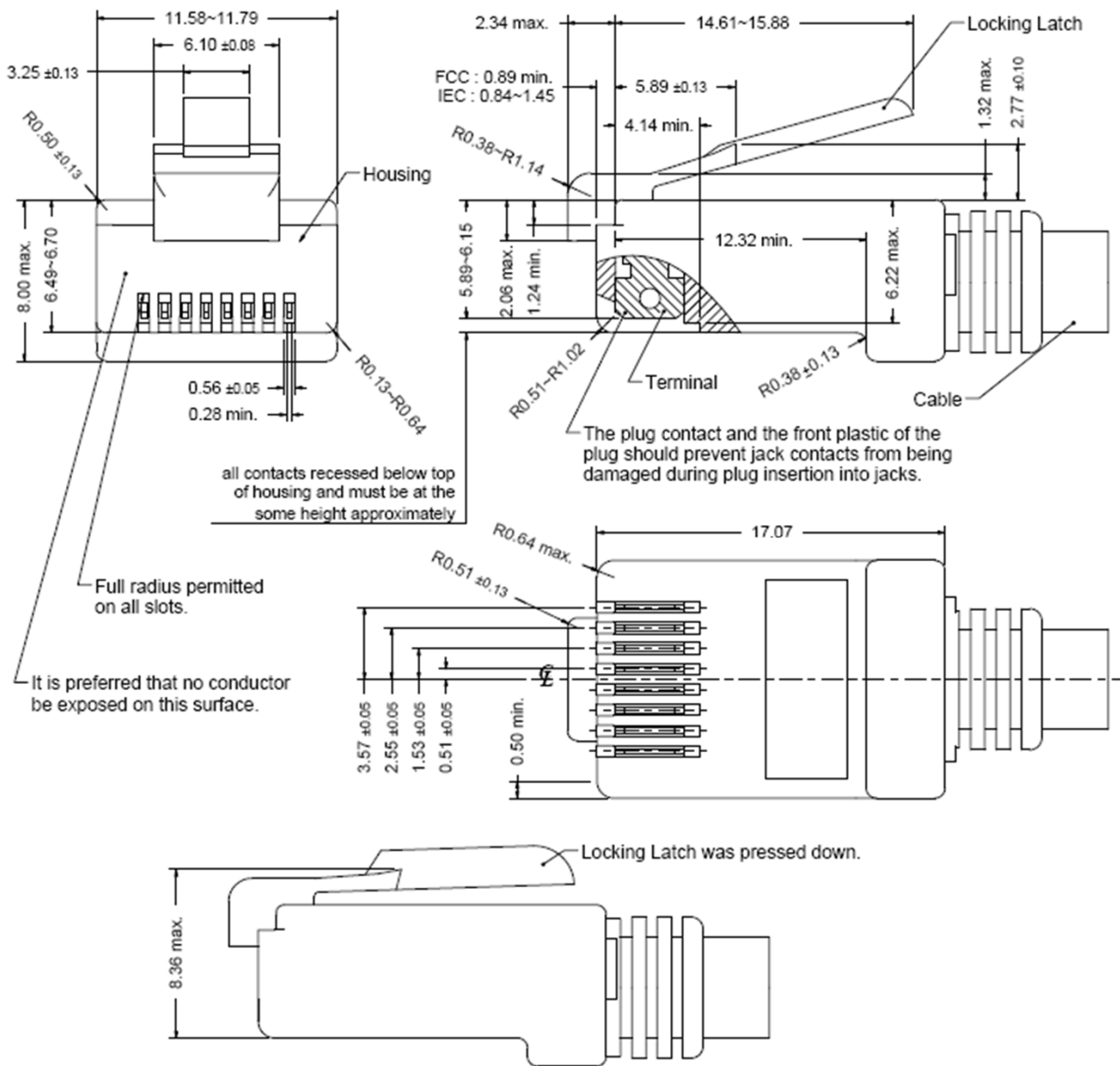

- All dimensions follow :
FCC subpart F, 68,500, Figure (C)(2)(i) & (C)(2)(ii) & (C)(3)(i)
IEC 60603-7
- All plugs must be meeting the requirements of plug Go & No-Go gauge.
Gauge follow : FCC subpart F, 68,500, Figure (C)(4)(i) & (C)(5)(i)
- There must be no damage to Housing and Locking Latch.
- There must be no nicks and cuts in cable.
- Durability : 750 cycles generally

2. REQUIREMENTS

2.1 Design and Construction

Product shall be of design, construction and physical dimensions specified on applicable.

2.2 Material

2.2.1 Terminal Parts (Underplating :50μ" min. Nickel overall)

2.2.1.1 RJ Terminal : YCUT-FX-H, Thickness=0.30mm

Finish : Contact Area : 30μ" min. Gold

2.2.1.2 Input Terminal : Brass, Thickness=0.35mm

Finish : 100μ" min. Bright Tin

2.2.1.3 Case Terminal : Brass, Thickness=0.30mm

Finish : 100μ" min. Bright Tin

2.2.2 Plastic Parts <UL94V-0>

2.2.2.1 Housing : PA6T, Black

2.2.2.2 Case : PA6T, Black

2.2.2.3 Spacer : PA6T, Black

2.2.2.4 Terminal Cover : PA6T, Black

2.2.2.5 Terminal Base : PA6T, Black

2.2.2.6 Insert : PA6T, Black

2.2.3 Shield Parts

2.2.3.1 Front Shield : Stainless Steel, Thickness=0.20mm, unplating

2.2.3.2 Back Shield : Stainless Steel, Thickness=0.20mm, Pre-soldering

2.3 Operating and Storage Temperature

Operating Temperature : 0°C to +70°C

Storage Temperature : -40°C to +85°C

2.4 RJ45 specifications

Insulation Resistance : 500MΩ min.

Insertion force with the latch depressed : 22N max

Removal force with the latch depressed : 44N max

Locking Force of Plug Latch : 50N min. @ 60+/-5 sec

Durability : 2500 cycles

2.5 Performance and Test Description

Product is designed to meet electrical, mechanical and environmental performance requirements specified in below table. All tests are performed at ambient environmental conditions per MIL-STD-1344A and EIA-364 unless otherwise specified.

2.6 Packaging and Packing

All parts shall be packaged and packed to protect against physical damage 、 corrosion and deterioration during shipment and storage.

3. ELECTRICAL CHARACTERISTICS @ 25°C

3.1 Schematic

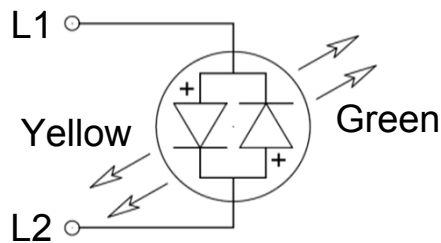
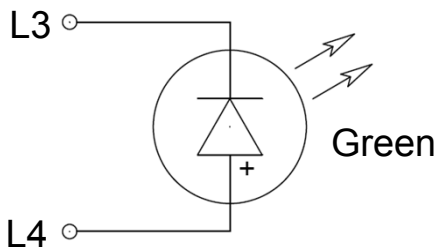
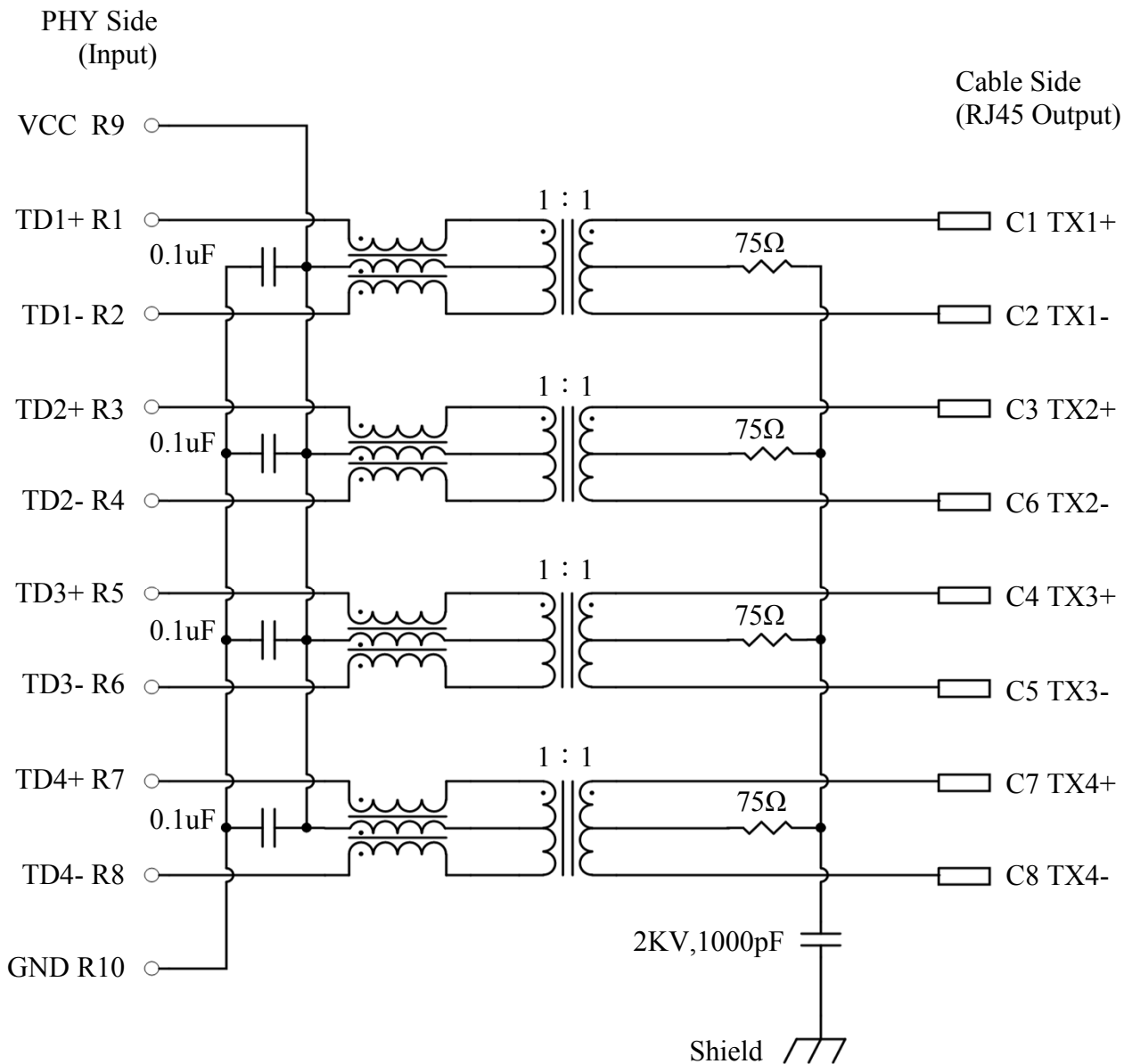

Emitting Color	λ_p (nm)	$V_f @ I_f=20mA$	$I_r @ V_r=5V$
Green	570	1.7 ~2.6 V	10 μ A max.
Yellow	588	1.7 ~2.6 V	10 μ A max.

3.2 Transmitter filter & Receiver filter

Type : Balance low pass 100Ω impedance

Insertion loss : 1~100 MHz -1.0dB max.

Return loss : 1~30 MHz -18dB min. load 100Ω

30~60MHz -16dB min. load 100Ω

60~80MHz -12dB min. load 100Ω

80~100MHz -10dB min. load 100Ω

3.3 Common Mode Rejection

@ 1~100 MHz -30dB min.

3.4 Cross Talk

@ 1~100 MHz -30dB min.

3.5 Inductance @ 100KHz, 0.1V, 8mA DC BIAS

Input (R1-R2), Input(R3-R4), Input (R5-R6), Input(R7-R8): 350 μH min.

3.6 HiPot Test

Input(R1-R2) To Output(C1-C2) : 1500Vac 60s or 2250Vdc 60s

Input(R3-R4) To Output(C3-C6) : 1500Vac 60s or 2250Vdc 60s

Input(R5-R6) To Output(C4-C5) : 1500Vac 60s or 2250Vdc 60s

Input(R7-R8) To Output(C7-C8) : 1500Vac 60s or 2250Vdc 60s

4. DIPPING TEMPERATURE PROFILE

Note :

The measuring point for the specified temperature shall be on the soldered part of the lead.

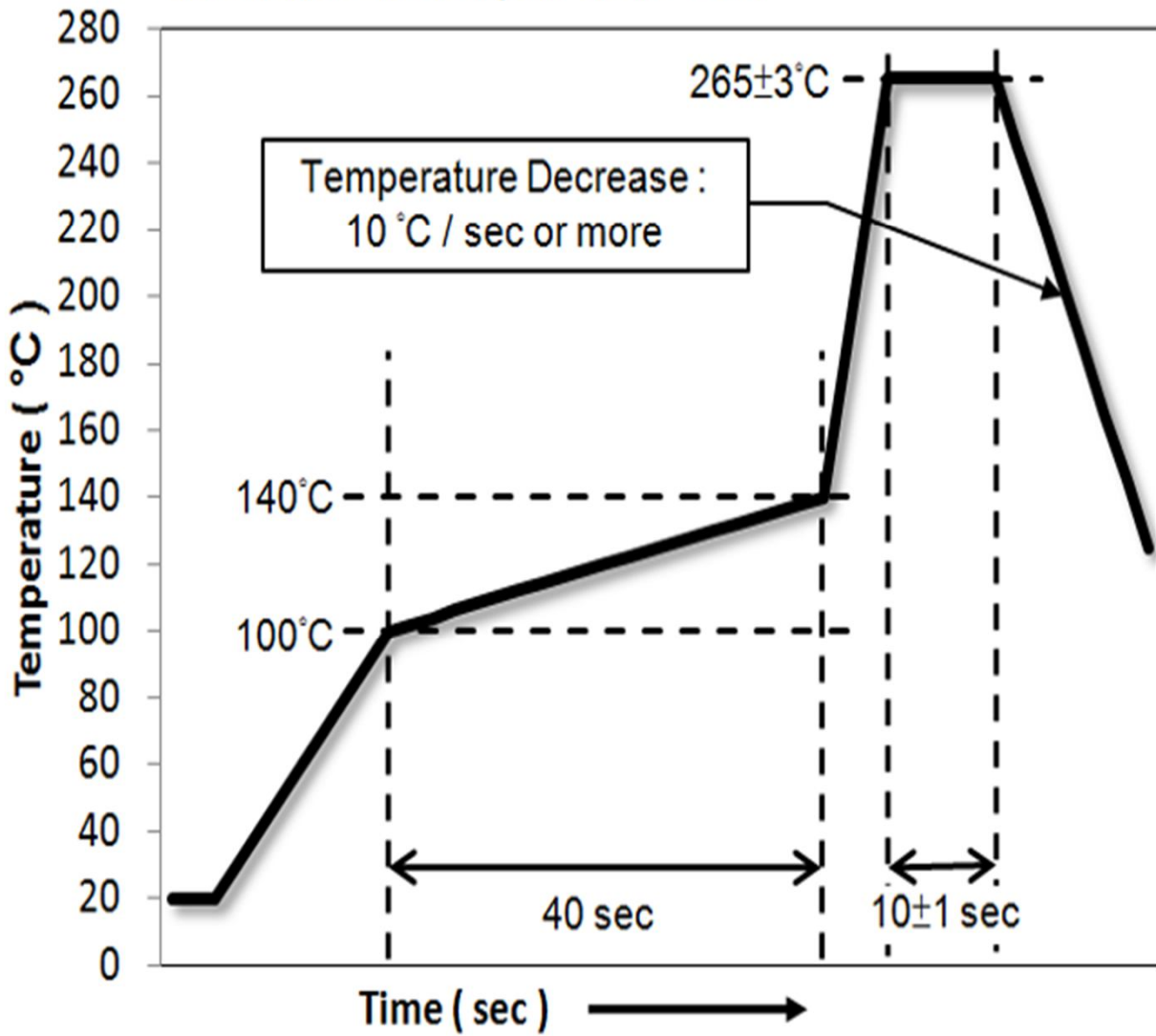

5. Revision History

Issue Date	Revision	Comments	Operator
2016/11/22	A	Initial Release .	Max