

APPROVAL SHEET

To :

Customer P/N :

SINGATRON P/N : 2TJRN2-ZZ-0046

Description : RJ45 multiport 2X1

Through Hole

10/100/1000 Base-T

Contact Area : Gold Flash

LED : L-Green; R-Green/Orange

Light Pipe : Upper/Lower Port

POE 30W



Spec No.
RN219011-00

Update Date
2019/4/16

Revision
A

Approved	Checked	Prepared

SINGATRON U.S.A.
13925 MAGNOLIA AVE
CHINO, CA 91710 USA

1. MECHANICAL DIMENSION

Product Dimension

Unit:mm	General Tolerance :	X.X : ± 0.38
		X.XX : ± 0.20

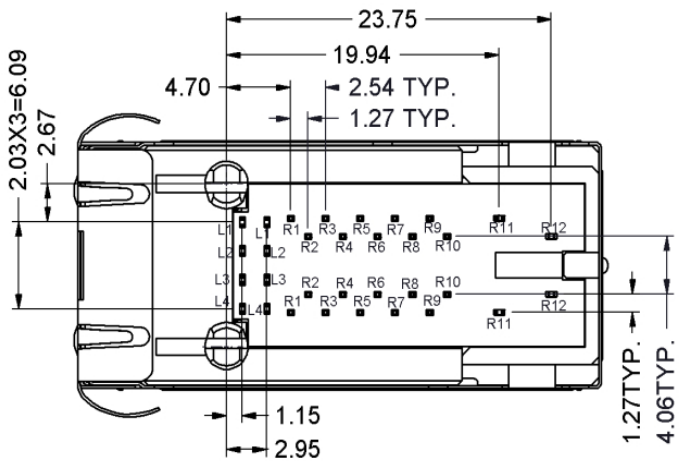
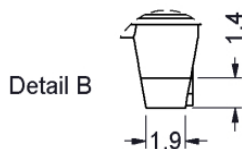
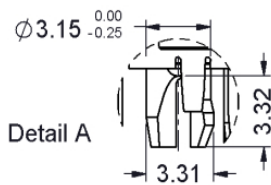
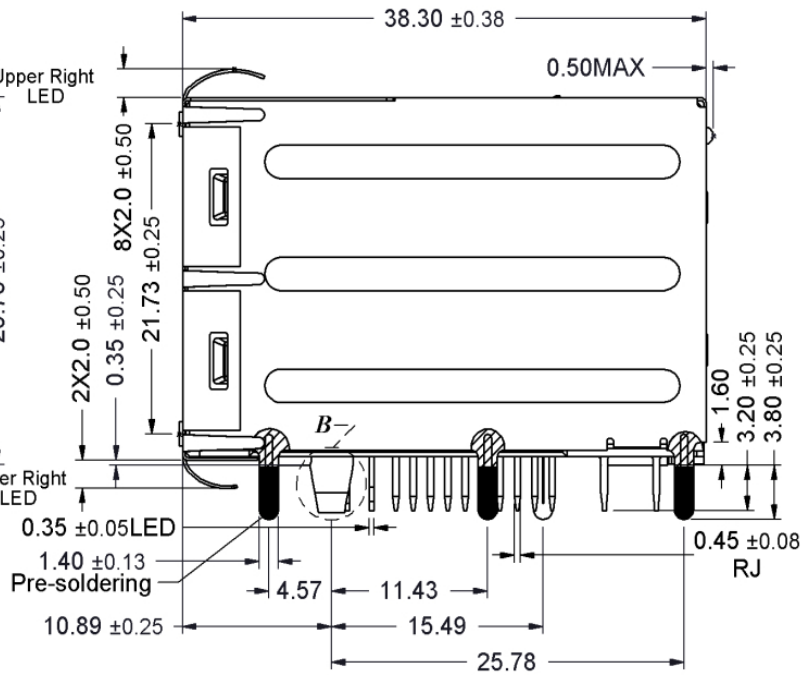
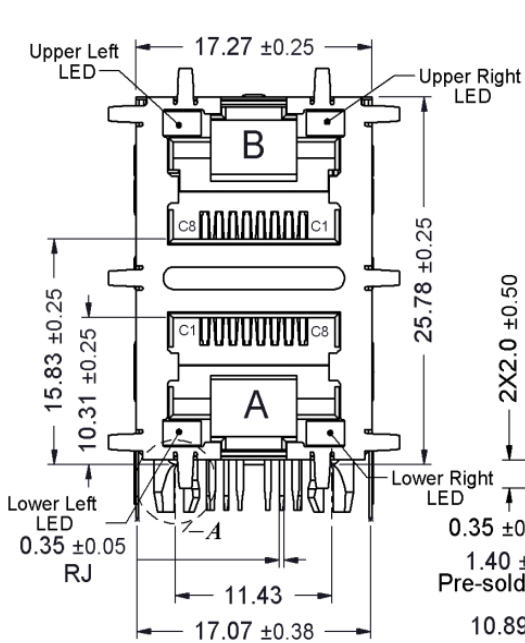
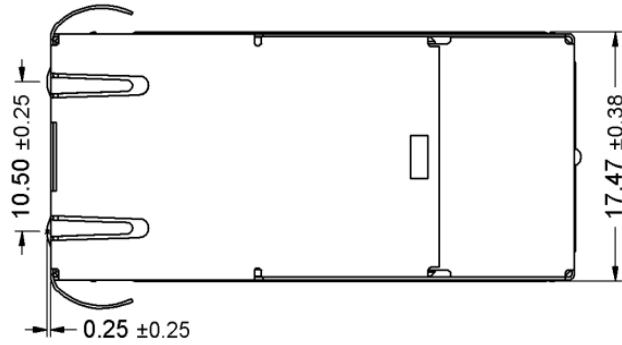
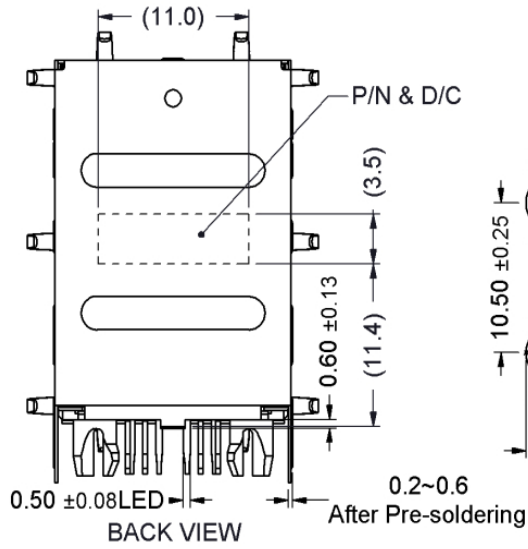

Recommended PCB Layout. Component side of board

All dimension units are "mm".

All dimension tolerances are ±0.05mm unless otherwise specified.

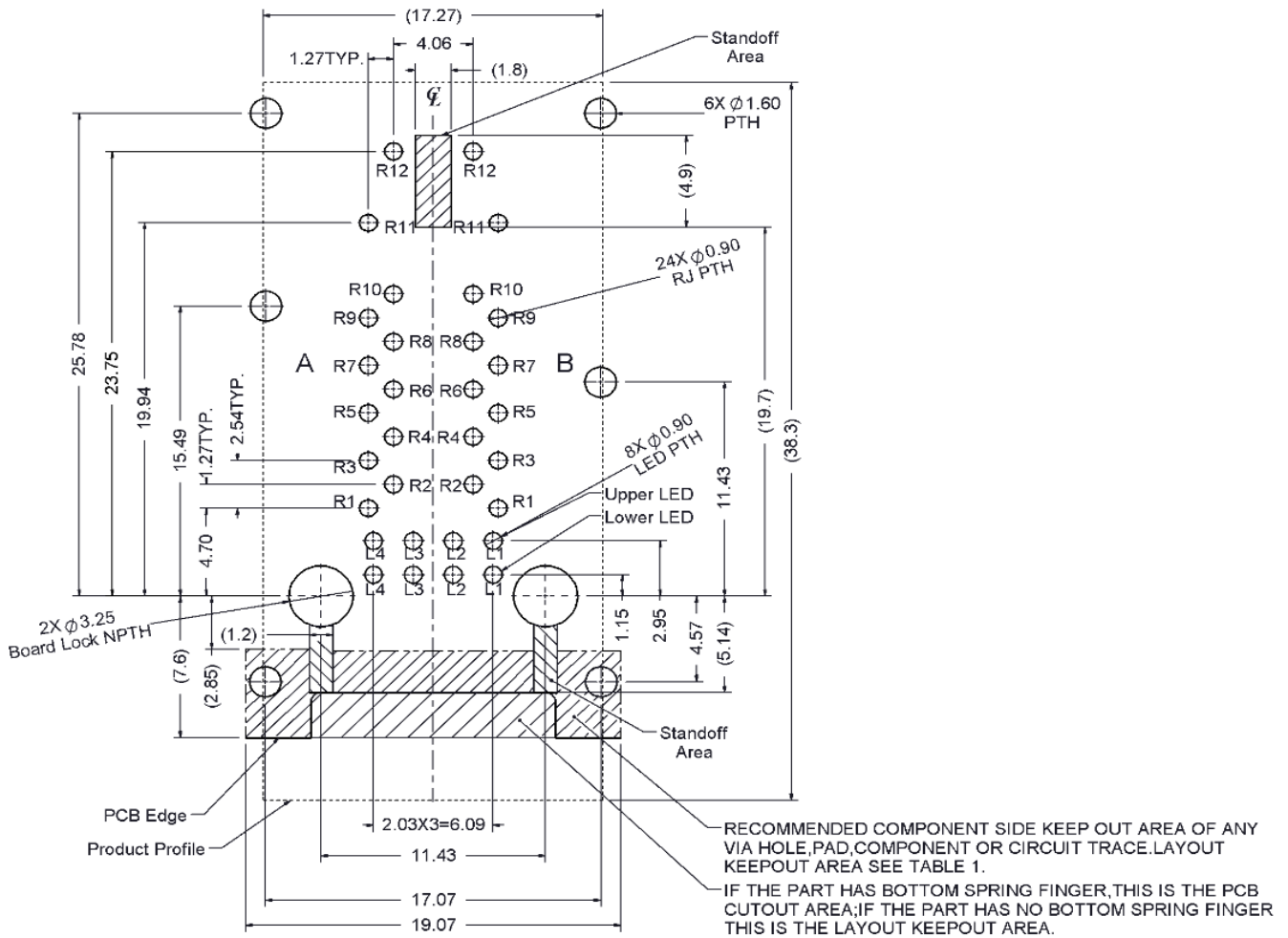
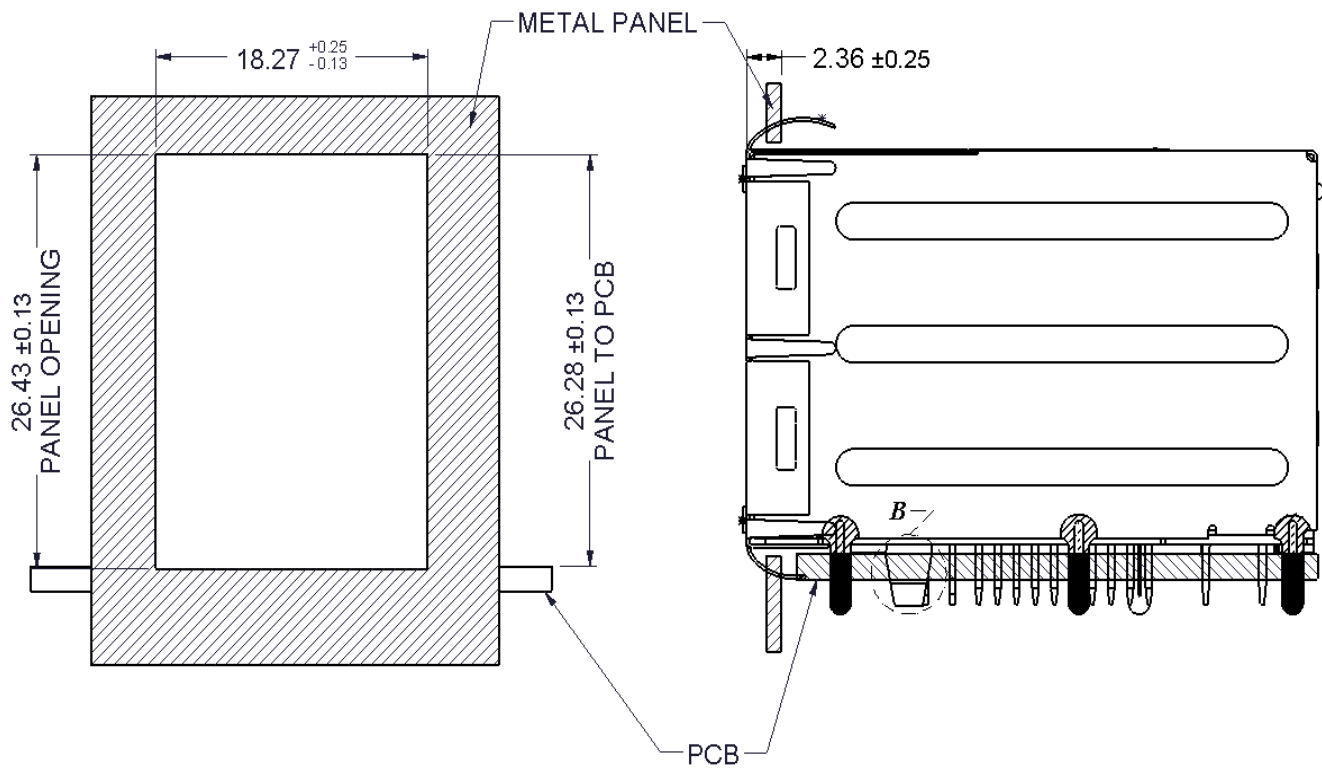

Table1

Layout Layer	Trace	component	Grounding	Test Point	Via Hole	PTH	NPTH
Component side	X	X	O	X	X	X	O
Inner layer	O	NA	O	NA	O	X	O
Bottom side	O	O	O	O	O	X	O

X--Forbid; O--OK; NA--Not Applicable.

Recommended Panel cutout



2. Packing Information

40 pcs finished goods per tray

5 trays (200 pcs finished goods) per inner box

4 Inner boxes (800 pcs finished goods) per master carton

3. Standard RJ45 Plug Specification

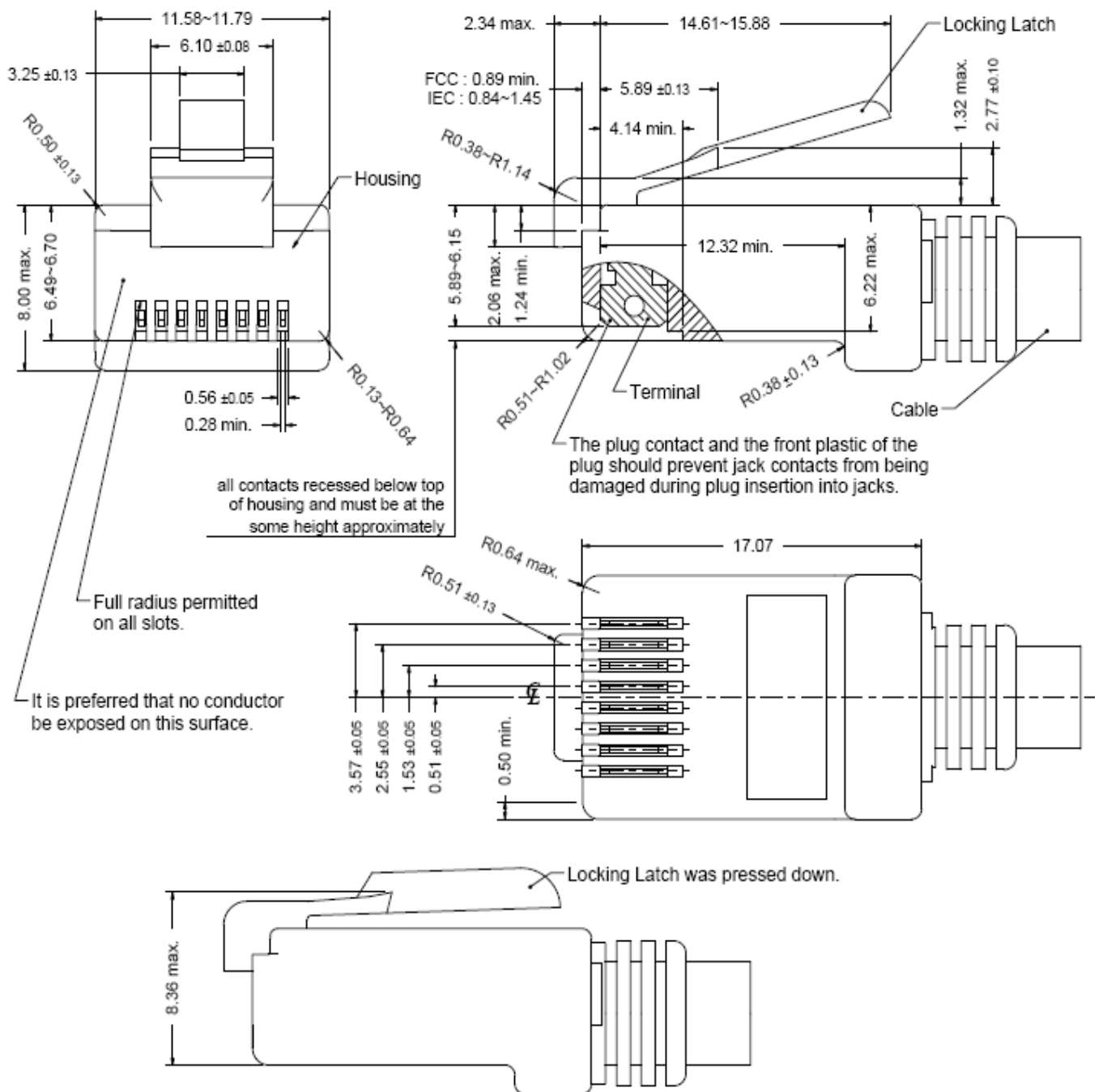

- All dimensions follow :
FCC subpart F, 68,500, Figure (C)(2)(i) & (C)(2)(ii) & (C)(3)(i)
IEC 60603-7
- All plugs must be meeting the requirements of plug Go & No-Go gauge.
Gauge follow : FCC subpart F, 68,500, Figure (C)(4)(i) & (C)(5)(i)
- There must be no damage to Housing and Locking Latch.
- There must be no nicks and cuts in cable.
- Durability : 750 cycles generally

4. REQUIREMENTS

Design and Construction

Product shall be of design, construction and physical dimensions specified on applicable.

Material

Terminal Parts (Underplating : 50 μ " min. Nickel overall)

RJ Terminal : Phosphor Bronze, Thickness=0.30mm

Finish : Contact Area : Gold Flash

Input Terminal : Brass, Thickness=0.35mm

Finish : 100 μ " min. Bright Tin

Case Terminal : Brass, Thickness=0.30mm

Finish : 100 μ " min. Bright Tin

Plastic Parts <UL94V-0>

Housing : PA6T, Black

Case : PA6T, Black

Spacer : PA6T, Black

Terminal Cover : PA6T, Black

Terminal Base : PA6T, Black

Insert : PA6T, Black

Cover : PA6T, Black

Light Pipe : PC, Transparent

Shield Parts

Front Shield : Stainless Steel, Thickness=0.20mm, unplating

Back Shield : Stainless Steel, Thickness=0.20mm, Pre-soldering

5. Operating and Storage Temperature

Operating Temperature : 0°C to +70°C

Storage Temperature : -40°C to +85°C

6. RJ45 specifications

Insulation Resistance : 500MΩ min.

Insertion force with the latch depressed : 20N max.

Removal force with the latch depressed : 20N max.

Locking Force of Plug Latch : 50N min. @ 60+/-5 sec.

Durability : 750 cycles

7. Performance and Test Description

Product is designed to meet electrical, mechanical and environmental performance requirements specified in below table.

All tests are performed at ambient environmental conditions per MIL-STD-1344A and EIA-364 unless otherwise specified.

8. Packaging and Packing

All parts shall be packaged and packed to protect against physical damage, corrosion and deterioration during shipment and storage.

9. ELECTRICAL CHARACTERISTICS @ 25°C

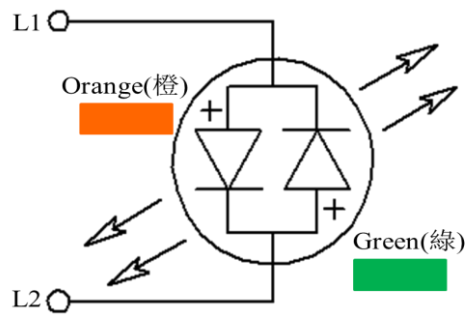
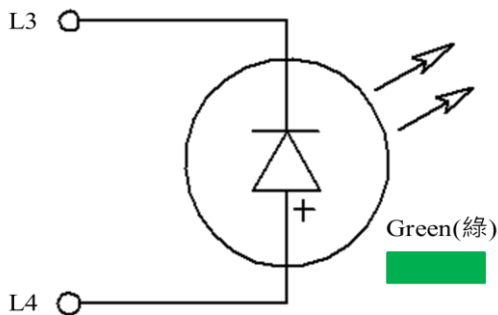
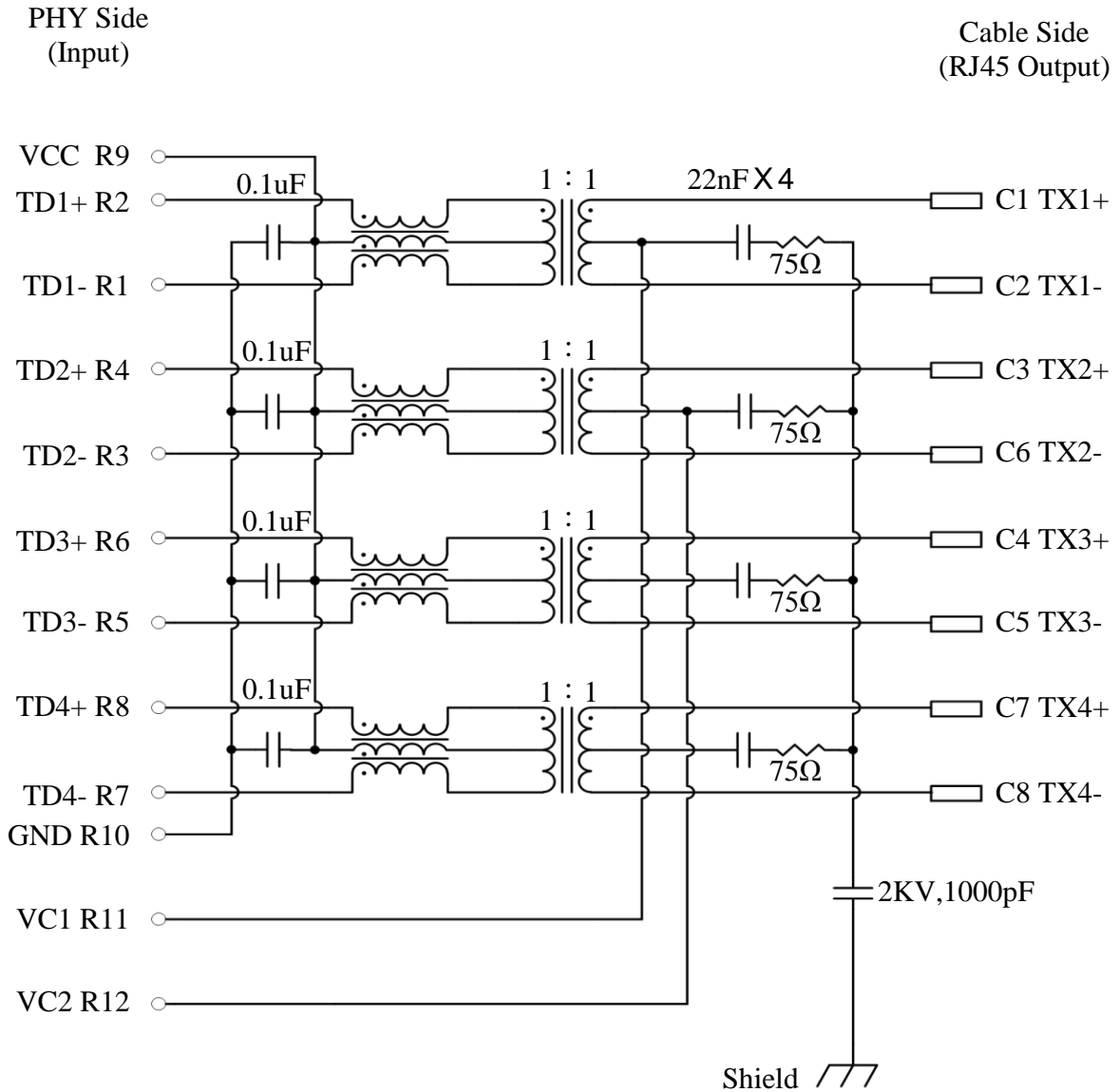

Emitting Color	λ_p (nm)	$V_f @ I_f=20mA$	$I_r @ V_r=5V$
Green	570	1.7 ~2.6 V	10 μ A max.
Orange	605	1.7 ~2.6 V	10 μ A max.

Transmitter filter & Receiver filter

Type : Balance low pass 100Ω impedance

Insertion loss : 1~100MHz -1.0dB max.

Return loss :	1~30MHz	-18dB min.	load 100Ω
	30~60MHz	-16dB min.	load 100Ω
	60~80MHz	-12dB min.	load 100Ω
	80~100MHz	-10dB min.	load 100Ω

Common Mode Rejection

@1~100 MHz -30dB min.

Cross Talk

@ 1~100MHz -30dB min.

Inductance (OCL) @ 100KHz, 0.1V, 8mA DC BIAS

Input (TD3+, TD3-) ; (TD4+, TD4-) : 350 μH min.

Inductance (OCL) @ 100KHz, 0.1V, 11mA DC BIAS

Input(TD1+, TD1-); (TD2+, TD2-) 350 μH min.

HiPot Test

Input (TD1+,TD1-) To Output(TX1+,TX1-) : 1500Vac 60s or 2250Vdc 60s

Input (TD2+,TD2-) To Output(TX2+,TX2-) : 1500Vac 60s or 2250Vdc 60s

Input (TD3+,TD3-) To Output(TX3+,TX3-) : 1500Vac 60s or 2250Vdc 60s

Input (TD4+,TD4-) To Output(TX4+,TX4-) : 1500Vac 60s or 2250Vdc 60s

Balanced DC line current

720mA MAX @57VDC continuous

1.2A MAX @57VDC for 200 milliseconds

10. WAVE SOLDERING TEMPERATURE PROFILE

Note :

The measuring point for the specified temperature shall be on the soldered part of the lead.

