

APPROVAL SHEET

To :

Customer P/N :

SINGATRON P/N : 2TJRT3-AD-0002

Description : RJ45 1X2 Tab Up

Through Hole

10G Base-T

Contact Area : 30 μ " Min. Gold

LED :L-Green/Yellow; R-Green/Yellow

Light Pipe



Spec No.
RT323011-00

Update Date
2023/3/29

Revision
A

Approved	Checked	Prepared

SINGATRON ENTERPRISE CO., LTD.

13925 Magnolia Avenue, Chino, CA 91710, U.S.A.

1. MECHANICAL DIMENSION

Product Dimension

Unit:mm	General Tolerance :	X.X : ± 0.38
		X.XX : ± 0.20

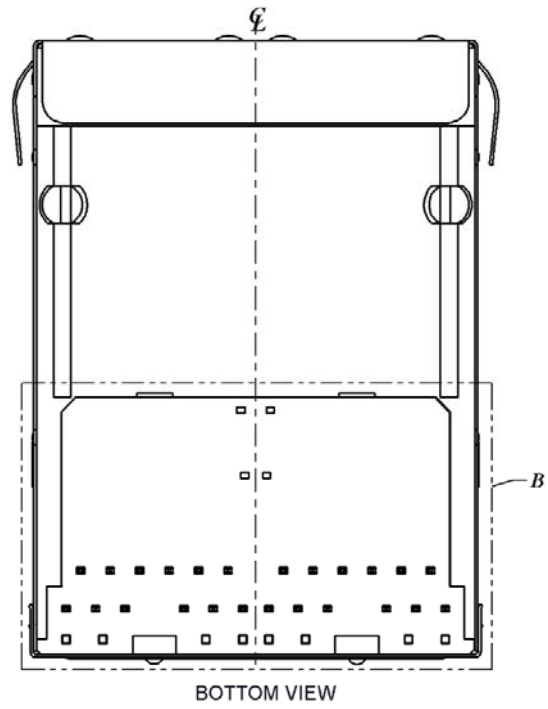
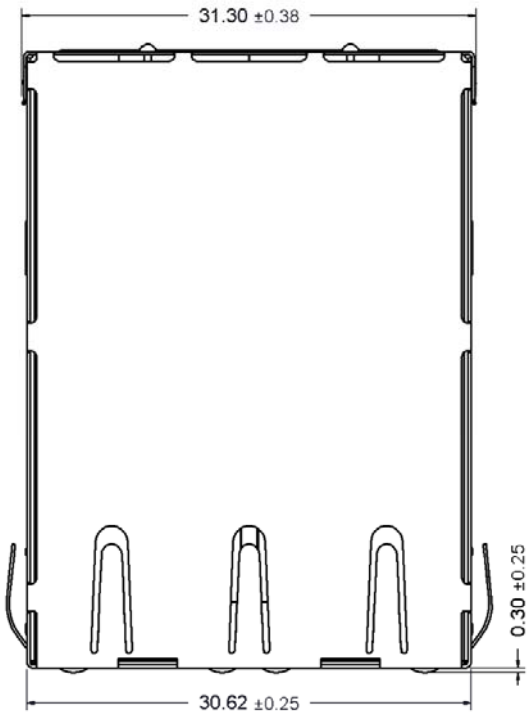

BOTTOM VIEW

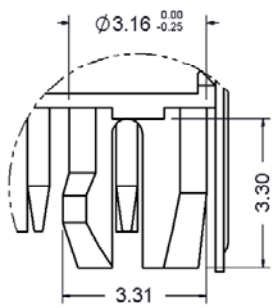
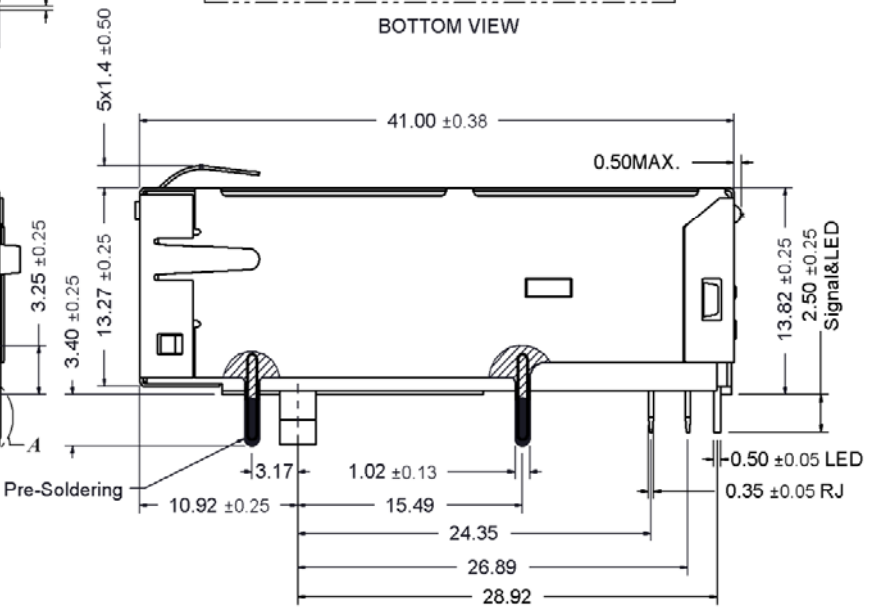
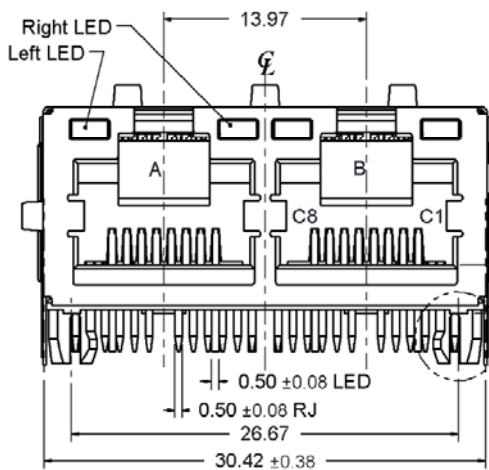

Detail A

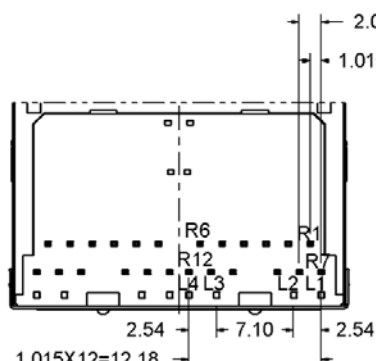

Detail B

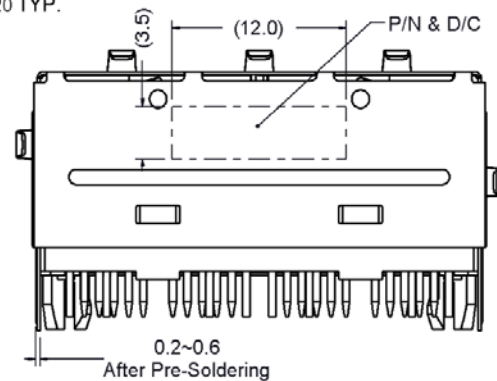

Recommended PCB Layout. Component side of board

All dimension units are "mm".

All dimension tolerances are ±0.05mm unless otherwise specified.

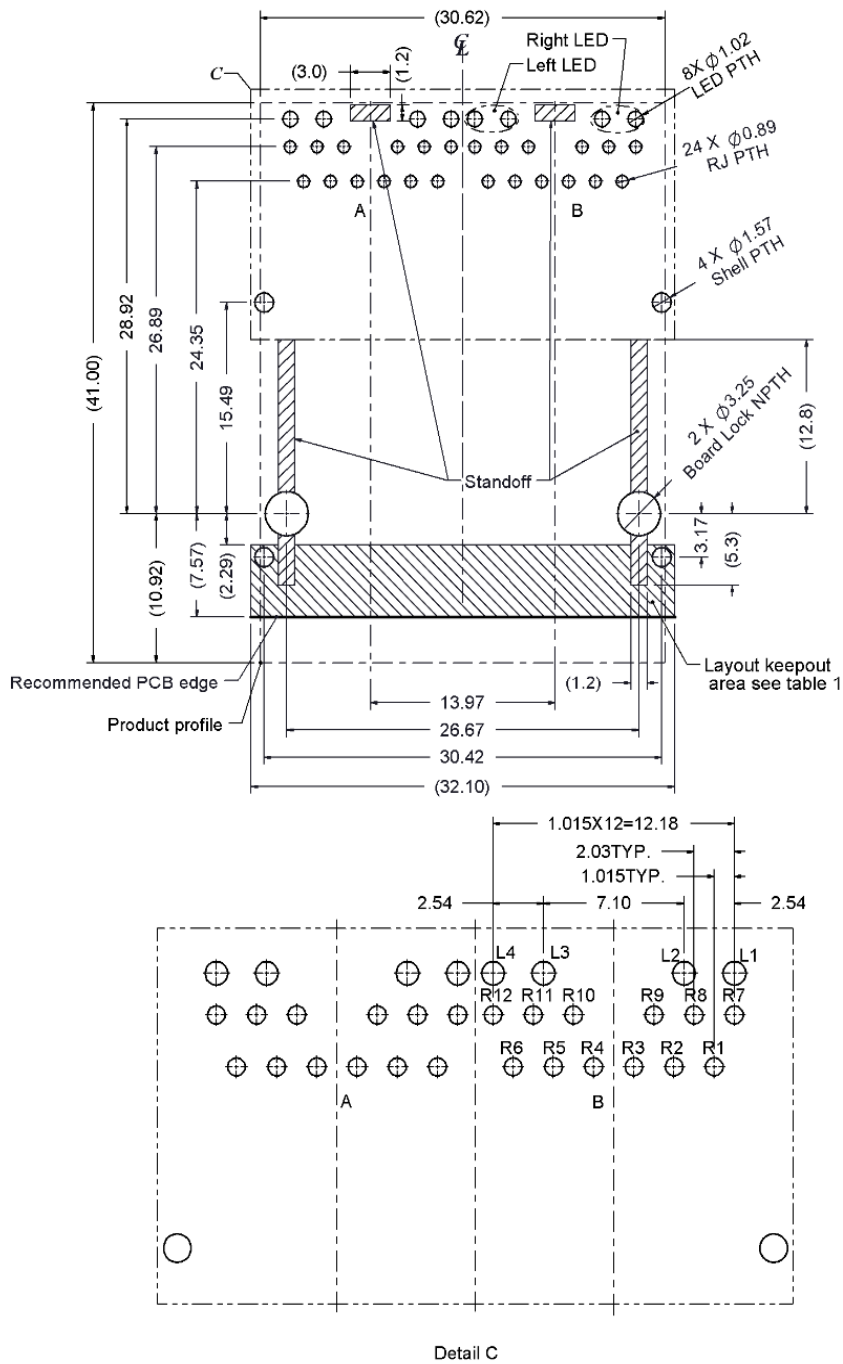

Layout / Layer	Trace	component	Grounding	Test Point	Via Hole	PTH	NPTH
Component side	X	X	O	X	X	X	O
Inner layer	O	NA	O	NA	O	X	O
Bottom side	O	O	O	O	O	X	O

X--Forbid; O--OK; NA--Not Applicable.

Recommended Panel cutout

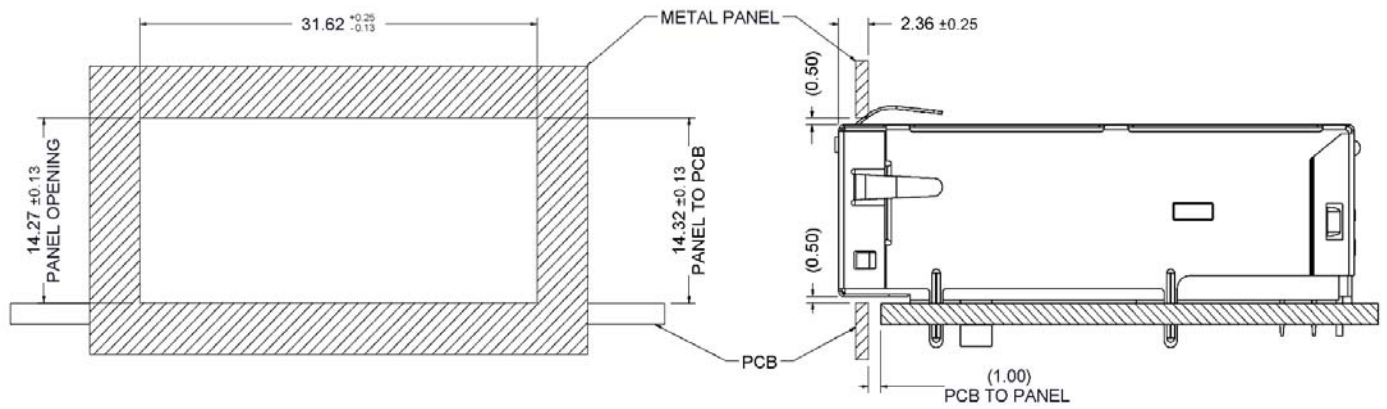

2. Packing Information

24 pcs finished goods per tray

6 trays (144 pcs finished goods) per inner box

4 Inner boxes (576 pcs finished goods) per master carton

3. Standard RJ45 Plug Specification

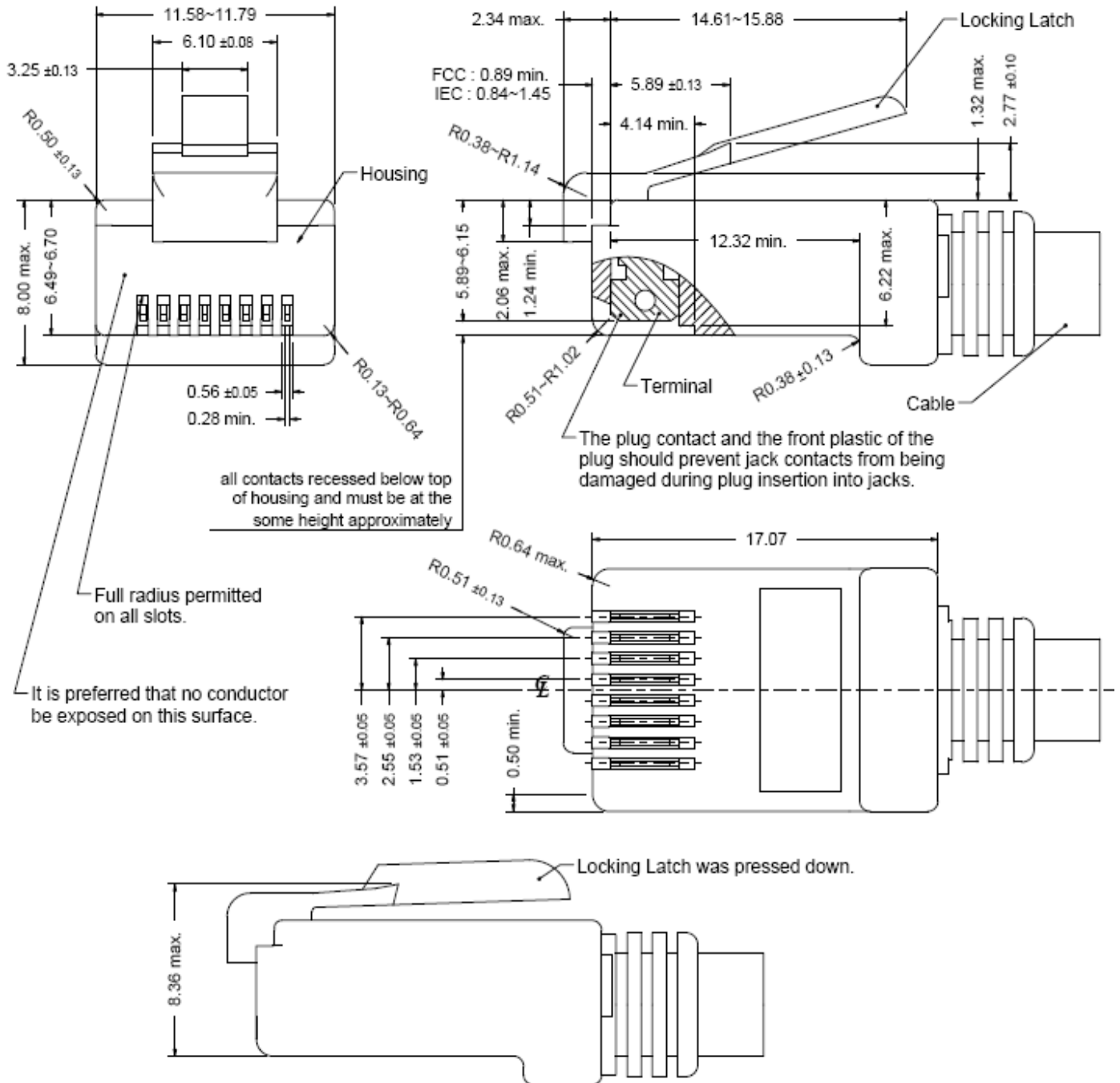

- All dimensions follow :
FCC subpart F, 68,500, Figure (C)(2)(i) & (C)(2)(ii) & (C)(3)(i)
IEC 60603-7
- All plugs must be meeting the requirements of plug Go & No-Go gauge.
Gauge follow : FCC subpart F, 68,500, Figure (C)(4)(i) & (C)(5)(i)
- There must be no damage to Housing and Locking Latch.
- There must be no nicks and cuts in cable.
- Durability : 750 cycles generally

4. REQUIREMENTS

Design and Construction

Product shall be of design, construction and physical dimensions specified on applicable.

Material

Terminal Parts (Underplating : 50 μ " min. Nickel overall)

RJ Terminal : Phosphor Bronze, Thickness=0.30mm

Finish : Contact Area :30 μ "min. Gold

Input Terminal : Brass, Thickness=0.35mm

Finish : 100 μ " min. Bright Tin

Case Terminal : Brass, Thickness=0.35mm

Finish : 100 μ " min. Bright Tin

Plastic Parts <UL94V-0>

Housing : PA6T, Black

Case : PA6T, Black

Spacer : PBT, Black

Light Pipe : PC, Transparent

Shield Parts : Stainless steel, Thickness=0.20mm, Pre-soldering

5. Operating and Storage Temperature

Operating Temperature : 0°C to +70°C

Storage Temperature : -40°C to +85°C

6. RJ45 specifications

Insulation Resistance : 500MΩ min.

Insertion force with the latch depressed : 20N max.

Removal force with the latch depressed : 20N max.

Locking Force of Plug Latch : 50N min. @ 60+/-5 sec.

Durability : 2500 cycles

7. Performance and Test Description

Product is designed to meet electrical, mechanical and environmental performance requirements specified in below table.

All tests are performed at ambient environmental conditions per MIL-STD-1344A and EIA-364 unless otherwise specified.

8. Packaging and Packing

All parts shall be packaged and packed to protect against physical damage, corrosion and deterioration during shipment and storage.

9. ELECTRICAL CHARACTERISTICS @25°C

PHY Side
(Input)

Cable Side
(RJ45 Output)

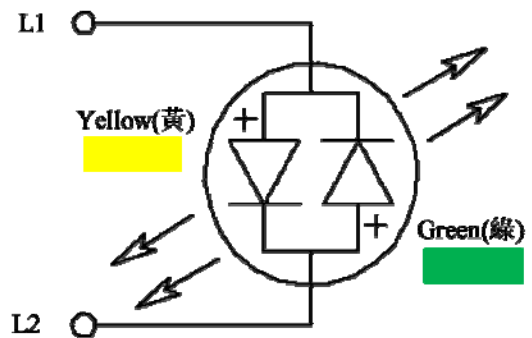
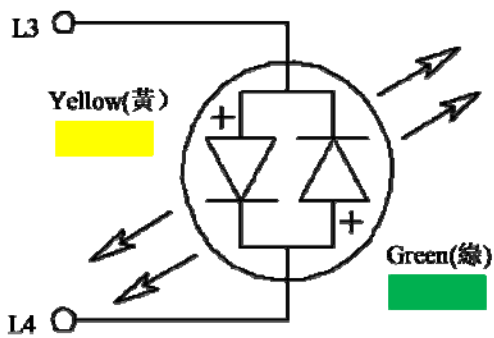
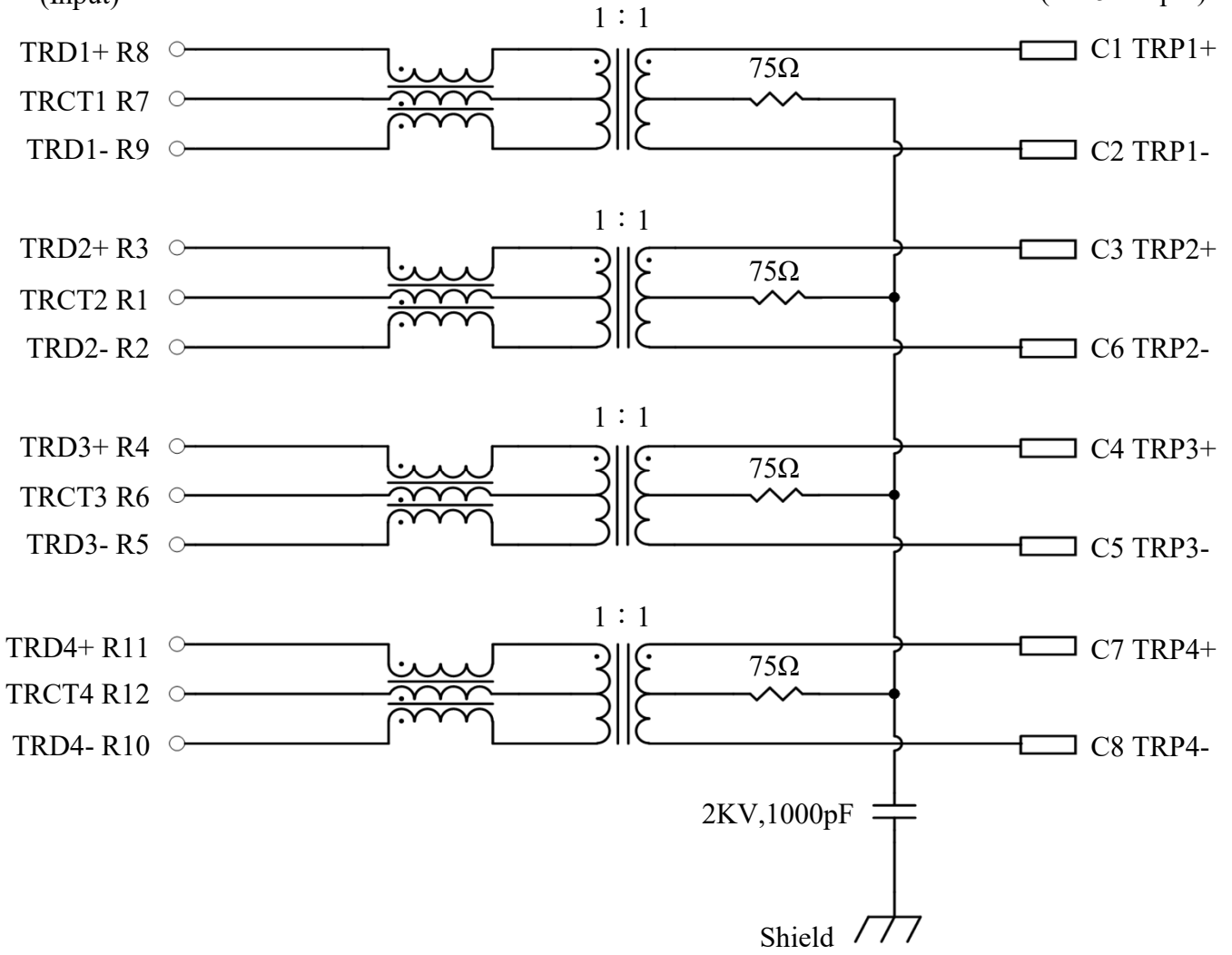

Emitting Color	λ_p (nm)	V_f @ $I_f=20mA$	I_r @ $V_r=5V$
Green	570	1.7 ~2.6 V	10 μ A max.
Yellow	588	1.7 ~2.6 V	10 μ A max.

Transmitter filter & Receiver filter

Type : Balance low pass 100Ω impedance

Insertion loss : 1~400MHz -2.0dB(-1.4TYP) max.

Return loss :	1MHz	-20dB min.	load 100Ω
	100MHz	-20dB min.	load 100Ω
	200MHz	-18dB min.	load 100Ω
	300MHz	-15dB min.	load 100Ω
	400MHz	-10dB min.	load 100Ω
	500MHz	-8dB min.	load 100Ω

Reflected CM to Diff Conversion(REF)

50MHz	-30dB min.
100MHz	-27dB min.
200MHz	-24dB min.
300MHz	-22dB min.
400MHz	-21dB min.
500MHz	-20dB min.

Reflected Diff to CM Conversion(REF)

1MHz	-48dB min.
100MHz	-35dB min.
400MHz	-24dB min.
500MHz	-24dB min.

CM to Diff Conversion (REF)

50MHz	-48dB min.
100MHz	-42dB min.
200MHz	-36dB min.
300MHz	-33dB min.
400MHz	-30dB min.
500MHz	-28dB min.

CM to CM Attenuation (REF)

1MHz	-22dB min.
500MHz	-20dB min.
800MHz	-20dB min.
1000MHz	-17dB min.

Cross Talk (REF)

1MHz	-34dB min.
350MHz	-23dB min.
500MHz	-23dB min.

A NEXT (REF)

1-500MHZ -58 dB Min

Inductance (OCL) @ 25°C, 100KHz, 100mV, 8mA DC BIAS

Input(TRD1+,TRD1-);(TRD2+,TRD2-); (TRD3+,TRD3-); (TRD4+,TRD4-):160uH min.

HiPot Test

PHY Side(input) To Cable Side(output) : 1500Vac 60s or 2250Vdc 60s

10. WAVE SOLDERING TEMPERATURE PROFILE

Note :

The measuring point for the specified temperature shall be on the soldered part of the lead.

