

APPROVAL SHEET

To :

Customer P/N :

Singatron P/N : 2TJS11-AD-0002

Description : RJ45 1X1 Tab down

Through Hole

10/100 Base-T

Contact Area : 30 μ " Min. Gold

LED : L-Green; R-Yellow



Spec No.
S1117054-00

Update Date
8/8/2017

Revision
A

Approved	Checked	Prepared

SINGATRON U.S.A.
13925 MAGNOLIA AVE
CHINO, CA 91710 USA

1. MECHANICAL DIMENSION

Product Dimension

Unit:mm	General Tolerance :	X.X : ± 0.38
		X.XX : ± 0.20

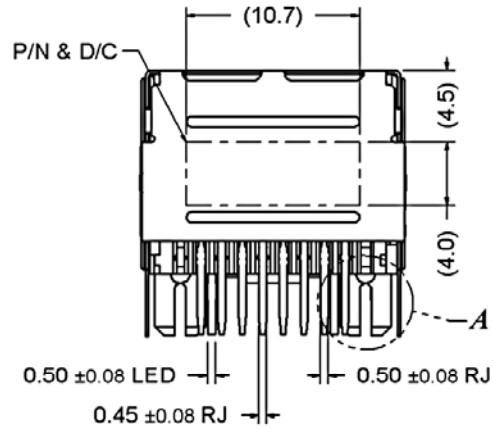
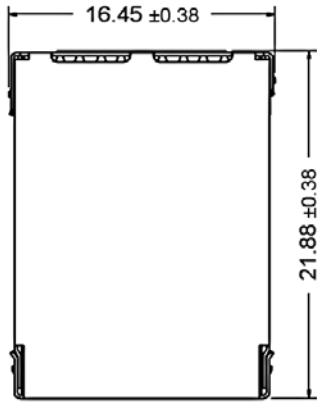

Back View

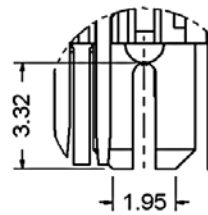
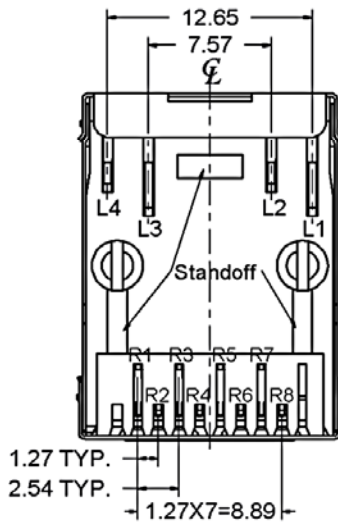
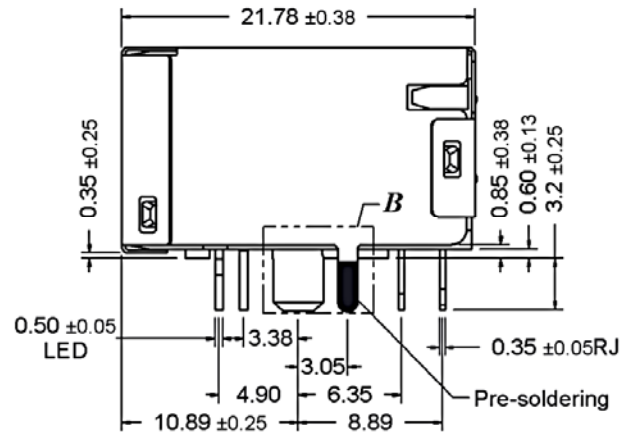
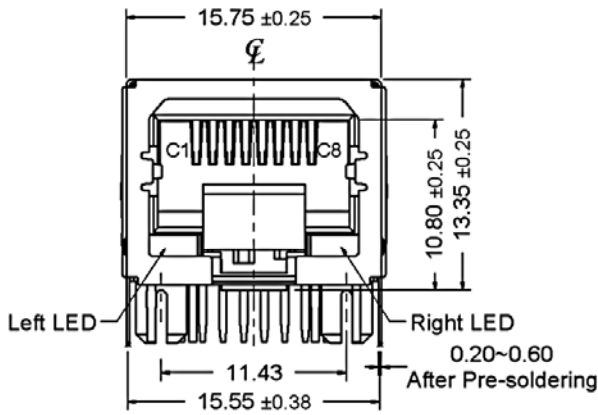

Detail A

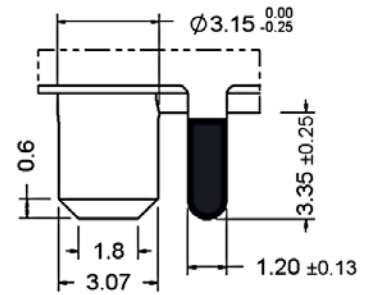

Detail B

Recommended PCB Layout. Component side of board

All dimension units are "mm".

All dimension tolerances are ±0.05mm unless otherwise specified.

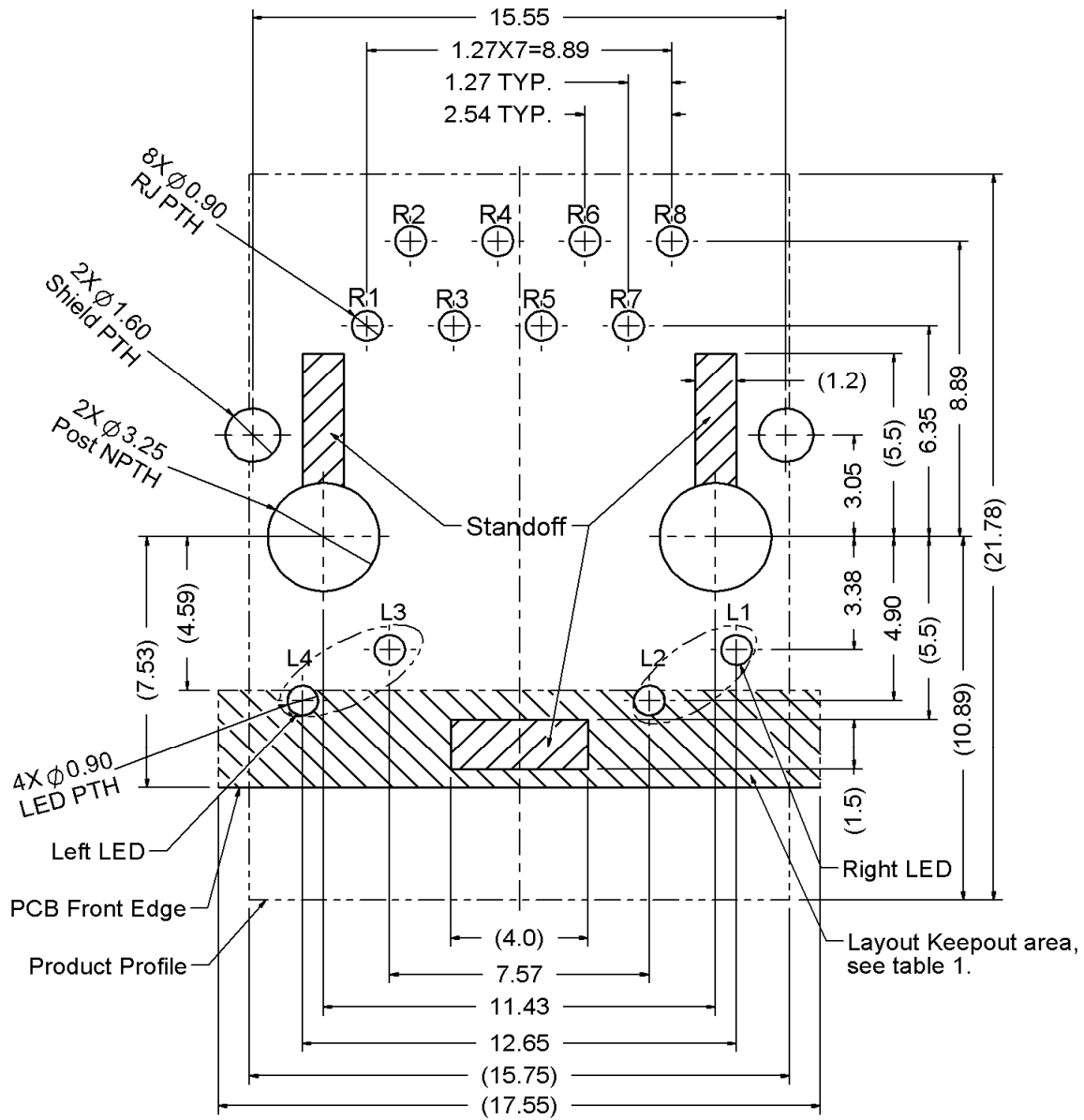
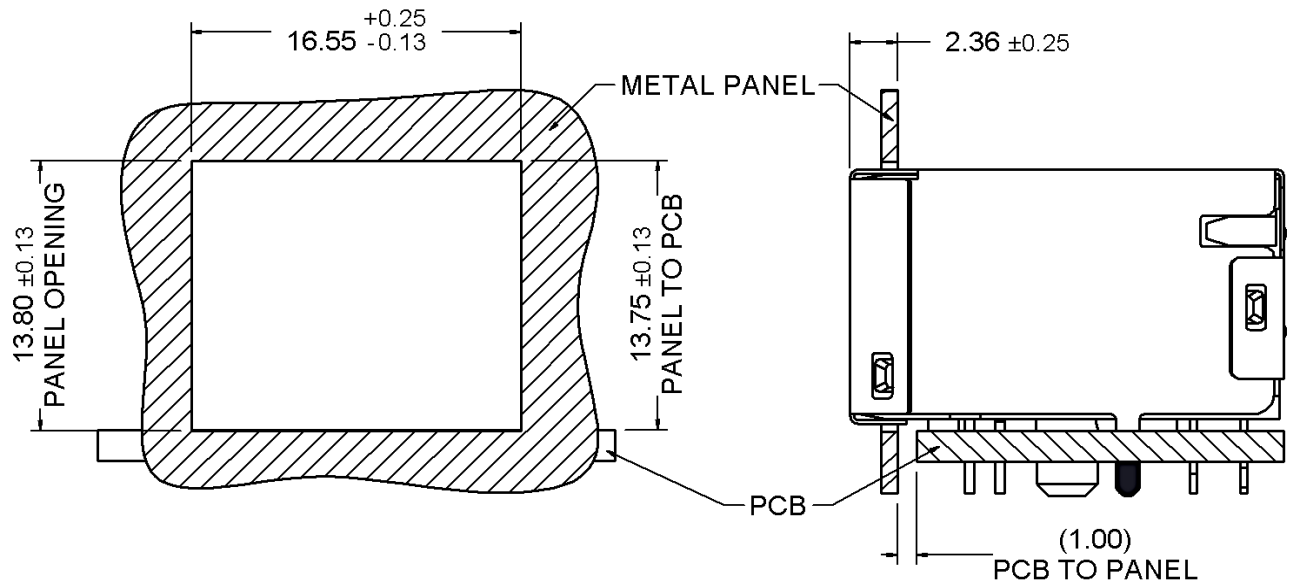

Table1

Layout Layer	Trace	component	Grounding	Test Point	Via Hole	PTH	NPTH
Component side	X	X	O	X	X	X	O
Inner layer	O	NA	O	NA	O	X	O
Bottom side	O	O	O	O	O	X	O

X--Forbid; O--OK; NA--Not Applicable.

Recommended Panel cutout



2. Packing Information

60 pcs finished goods per tray

7trays(420 pcs finished goods) per inner box

4 Inner boxes(1680 pcs finished goods) per master carton

3. Standard RJ45 Plug Specification

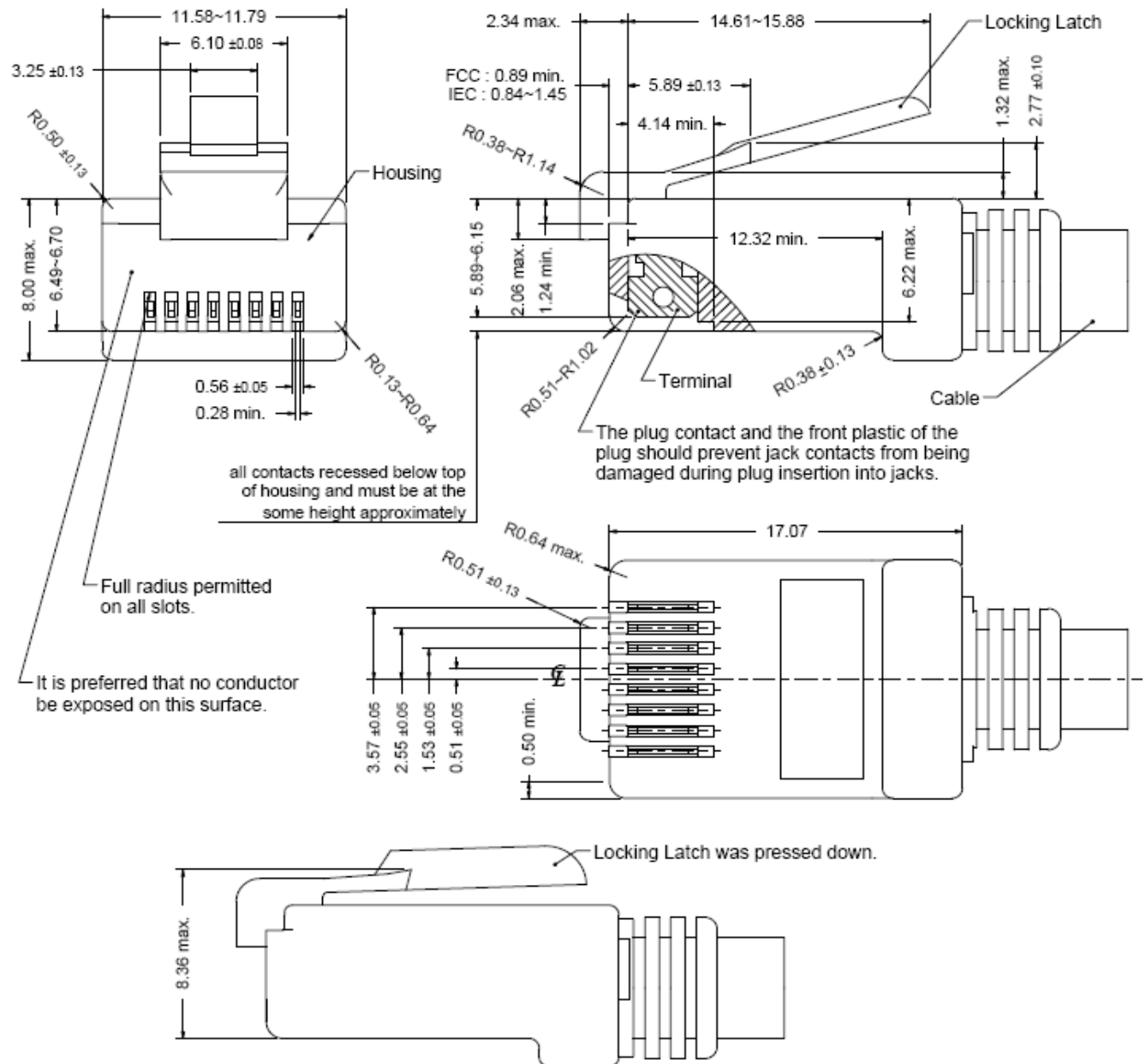

- All dimensions follow :

FCC subpart F, 68,500, Figure (C)(2)(i) & (C)(2)(ii) & (C)(3)(i)

IEC 60603-7

- All plugs must be meeting the requirements of plug Go & No-Go gauge.

Gauge follow : FCC subpart F, 68,500, Figure (C)(4)(i) & (C)(5)(i)

- There must be no damage to Housing and Locking Latch.

- There must be no nicks and cuts in cable.

- Durability : 750 cycles generally

4. REQUIREMENTS

Design and Construction

Product shall be of design, construction and physical dimensions specified on applicable.

Material

Terminal Parts (Underplating : 50 μ " min. Nickel overall)

RJ Terminal : Phosphor Bronze, Thickness=0.30mm

Contact Area: 30u" Min.Gold

Input Terminal : Brass, Thickness=0.35mm

Finish : 100 μ " min. Matte Tin

Cap. Terminal :Phosphor Bronze, Thickness=0.35mm

Finish : 100 μ " min. Matte Tin

Plastic Parts <UL94V-0>

Housing : PA6T, Black

Insert: PBT, Black

Shield Parts : Stainless steel , Thickness=0.20mm, Pre-soldering

5. Operating and Storage Temperature

Operating Temperature : 0°C to +70°C

Storage Temperature : -40°C to +85°C

6. RJ45 specifications

Insulation Resistance : 500MΩ min.

Insertion force with the latch depressed : 20N max.

Removal force with the latch depressed : 20N max.

Locking Force of Plug Latch : 50N min. @ 60+/-5 sec.

Durability : 2500 cycles

7. Performance and Test Description

Product is designed to meet electrical, mechanical and environmental performance requirements specified in below table.

All tests are performed at ambient environmental conditions per MIL-STD-1344A and EIA-364 unless otherwise specified.

8. Packaging and Packing

All parts shall be packaged and packed to protect against physical damage, corrosion and deterioration during shipment and storage.

9. ELECTRICAL CHARACTERISTICS @ 25°C

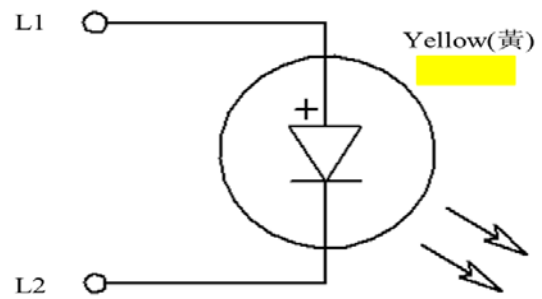
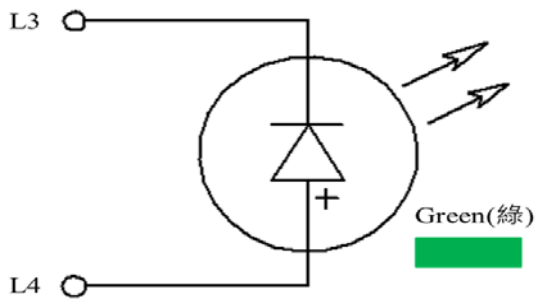
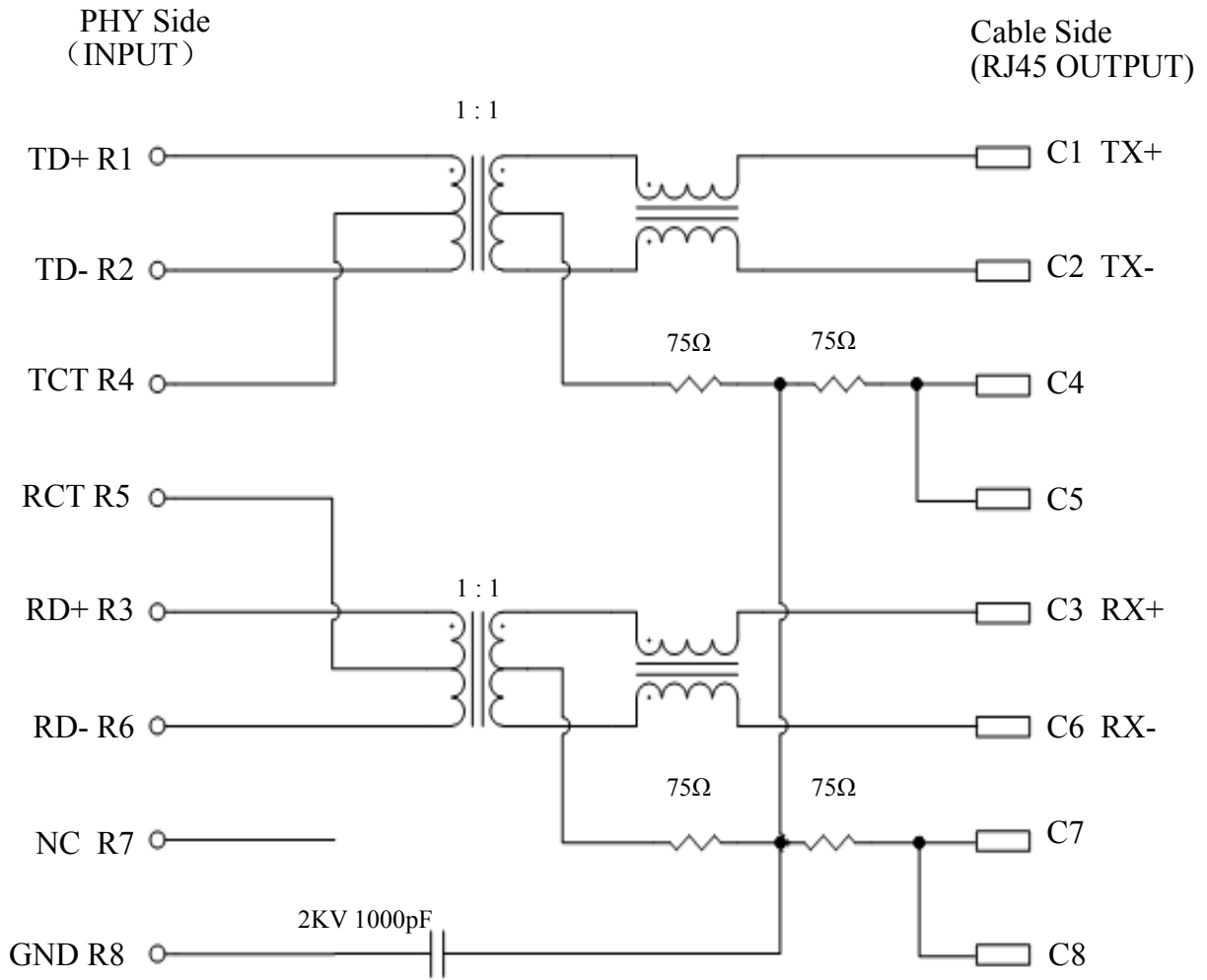

Emitting Color	λ_p (nm)	$V_f @ I_f=20mA$	$I_r @ V_r=5V$
Green	570	1.7 ~2.6 V	10 μ A max.
Yellow	588	1.7 ~2.6 V	10 μ A max.

Transmitter filter & Receiver filter

Type : Balance low pass 100Ω impedance

Insertion loss :	1 MHz	-1.0dB max.	
	100 MHz	-1.4dB max.	
Return loss :	1~30MHz	-16dB min.	load 100Ω
	30~60MHz	-14dB min.	load 100Ω
	60~80MHz	-10dB min.	load 100Ω

Common Mode Rejection

@1~100 MHz -30dB min.

Cross Talk

@ 1~100MHz -30dB min.

Inductance @ 100KHz, 0.1V

Input(TD+、TD-), (RD+、RD-) : 350 μH Typ.

HiPot Test

PHY Side(input) To Cable Side(output) : 2250Vdc

10. WAVE SOLDERING TEMPERATURE PROFILE

Note :
The measuring point for the specified temperature shall
be on the soldered part of the lead.

