

HF

REV	ECN No.	DATE	REMARK
A		2017.07.19	NEW RELEASE
A1		2019.06.12	Add HF Mark

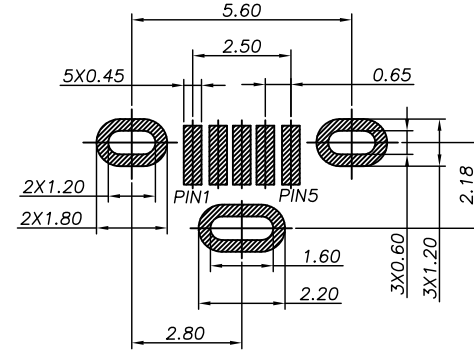

RECOMMENDED PCB LAYOUT(TOP VIEW)
GENERAL TOLERANCES:±0.05

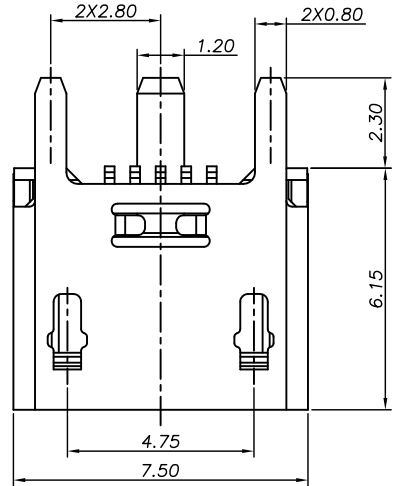
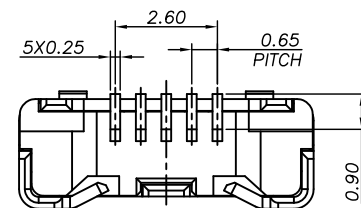
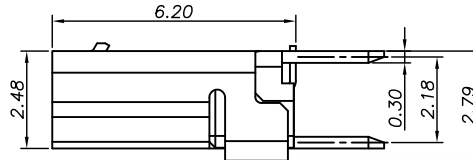
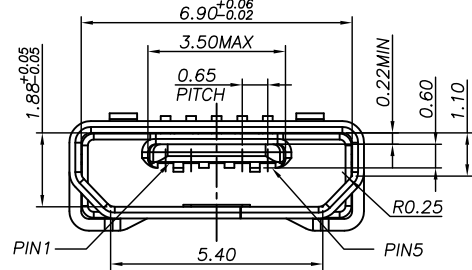

5	GND
4	ID
3	D+
2	D-
1	VBUS
PIN	NAME
PIN ASSIGNMENT	

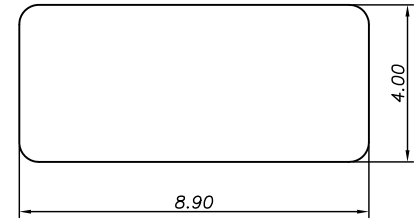

CAP DIMENSION SKETCH MAP

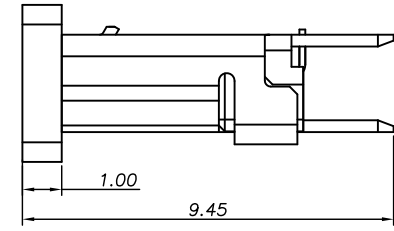

NOTE:

- MATERIAL SPECIFICATION:
 - HOUSING:LCP; UL94 V-0 BLACK.
 - CAP:LCP; UL94 V-0 BLACK.
 - CONTACTS: BRASS .
 - FRONT SHELL: STAINLESS STEEL
- PLATING SPECIFICATION:
 - CONTACTS:
 - Ni 50u" MIN. UNDER PLATED OVER ALL.
 - Au1u"MIN PLATED ON THE FUNCTIONAL AREA OF CONTACT.
 - FRONT SHELL:
 - Ni 30u" MIN. UNDER PLATED OVER ALL.
- MECHANICAL PERFORMANCE,
 - INSERTION FORCE: 3.5Kgf MAX
 - REMOVAL FORCE: 0.8kgf MIN
 - DURABILITY: 10000 CYCLES.
- ELECTRICAL PERFORMANCE,
 - CURRENT RATING:
 - VBUS & GND PINS: 1.8A MAX.
 - OTHER PINS: 0.5A MAX.
 - INSULATION RESISTANCE: 100MΩ MIN
 - DIELECTRIC WITHSTAND VOLTAGE,AC 100V FOR 1 MINUTE.

QUALITY SYMBOL	GENERAL TOLERANCES (UNLESS SPECIFIED)
▽=0	x.xxxxx ±---
▽=0	x.xxx ±---
▽=0	x.xx ±0.25
▽=0	x.x ±0.30
▽=0	ANGULAR ±---

Singatron Enterprise Co., Ltd.			
TITLE	MICRO USB 5P 直立式SMT无翻边外壳3支脚		
DWN	SLF 2017/07/19	PART NO.	2UB-MF042SLB11R-A-01
CHKD	David 2017/07/19	SCALE 1:1	UNIT: mm
APVD	David 2017/07/19	SIZE: A3	SHEET:1 OF 1
		REV:	A
CUSTOMER COPY			



ITEM	W	AO	BO	D	E	F	KO	PO	P2	P	T	REV	ECN No.	DATE	REMARK
DIM	24.0	2.94	7.50	1.5	1.75	11.5	10.35	4.0	2.0	12.0	0.50	A		2018.03.26	NEW RELEASE
TOLE	+0.3 -0.3	+0.1 -0.1	+0.1 -0.1	+0.1 -0.0	±0.1	±0.10	+0.1 -0.1	±0.1	±0.1	±0.1	±0.05				

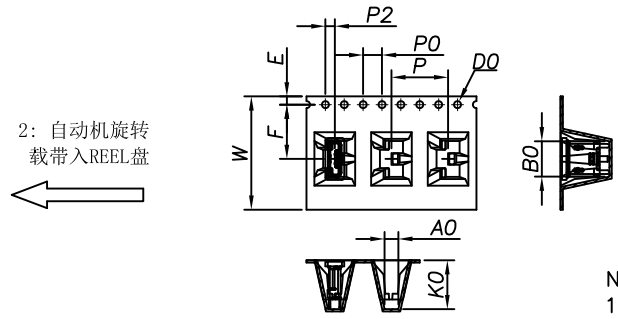
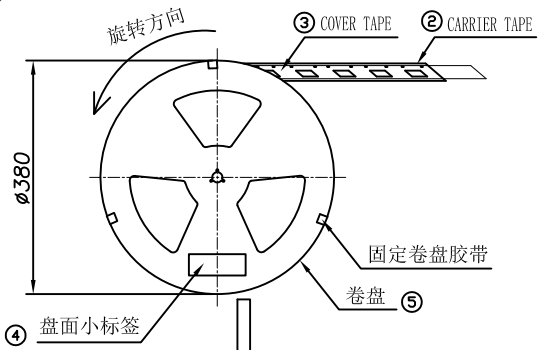

2: 自动机旋转
载带入REEL盘

1: 产品平整
放入载带

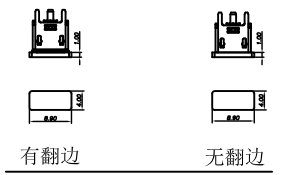

NOTE:
 1. QUANTITY/REEL: 600PCS
 数量/卷: 600PCS
 QUANTITY/INNER CARTON: 600 X 10 = 6000 PCS
 数量/箱: 600 X 10 = 6000 PCS
 2. FREE 16 CAVE IN THE FRONT CARRIER AND FREE 16 CAVE IN THE END CARRIER.
 包装带内圈空16格, 外圈空16格.

料号对照表:

料号	品名规格
2UB-MF042SLB11R-A-01	5P直立式外壳3支脚无翻边

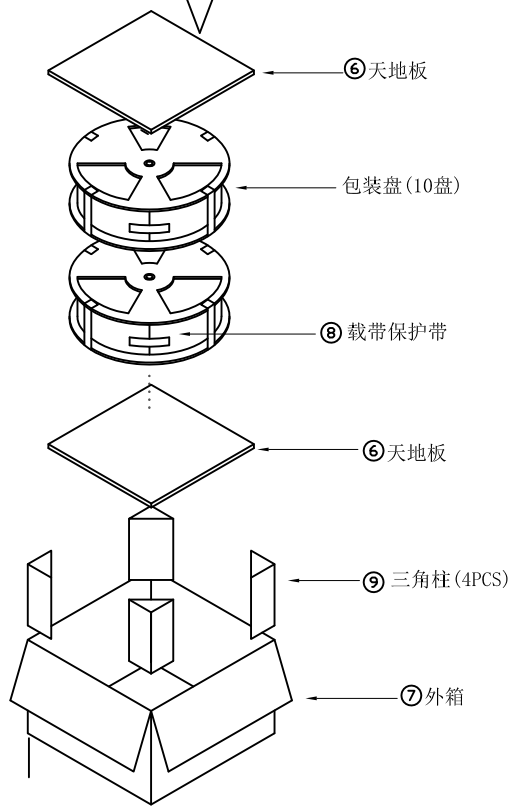

3: 将卷盘放入纸箱。

1	成品		5P直立式3支脚	6000PCS
2	CARRIER TAPE	PET	W=24mm T=0.50mm	7.8M
3	COVER TAPE	PET	W=21.3mm T=0.05mm	
4	标签		40mm*50mm	10PCS
5	卷盘	胶盘	□380mm*W28.5mm	2PCS
6	天地板	K=A	L330mm*W330mm	2PCS
7	外箱	K=A	L400mm*W400mm*320mm	1PCS
8	载带保护带			1PCS
9	三角柱	B=B	L320*W240	4PCS
序号	品名	规格	标示	用量

QUALITY SYMBOL	0	GENERAL TOLERANCES (UNLESS SPECIFIED)
	X.XXXXX	±
	X.XXXX	±
	X.XX	± 0.25
	X.X	± 0.30
	ANGULAR	±

Singatron Enterprise Co., Ltd.			
TITLE	MICRO UBS 5P直立式外壳3支脚 有翻边/无翻边		
DWN	SLF 2018/03/26	PART NO.	2UB-MF042SLB11R-A-01
CHKD	David2018/03/26	SCALE 1:1	UNIT: mm
APVD	David2018/03/26	SIZE: A3	SHEET: 1 OF 1 REV: A
CUSTOMER COPY			