

1 2 3 4 5 6 7 8

F

E

D

C

B

A

F

E

D

C

B

A

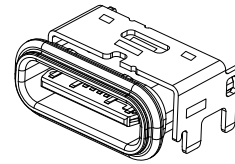
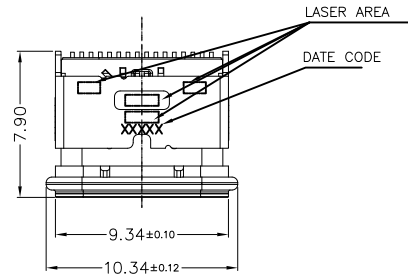
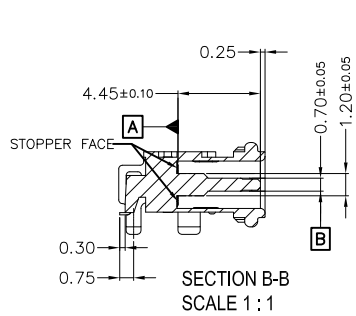

PIN ASSIGNMENT FOR USB C 16PIN							
A1	A4	A5	A6	A7	A8	A9	A12
GND	VBUS	CC1	D+	D-	SUB1	VBUS	GND
B12	B9	B8	B7	B6	B5	B4	B1
GND	VBUS	SUB2	D-	D+	CC2	VBUS	GND

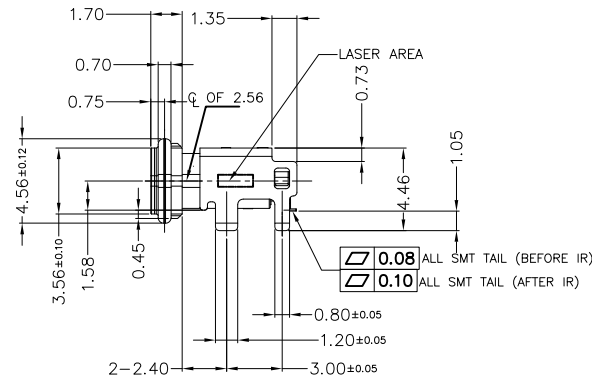
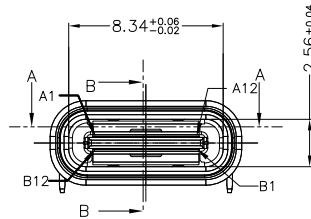
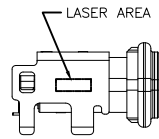
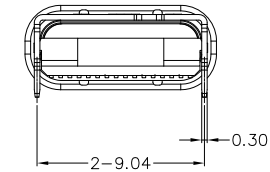

NOTES: (Unless otherwise specified)

- Dimension shall be interpreted per ANSI Y14.5M.
- Materials:
Insulator material: High Temperature Thermoplastic, UL 94V-0; Color: Black.
Contact material: Copper alloy. T=0.12mm
Gold 30u" Plated On Contact Area, G/F On Solder Area
50u" Ni Under Plated Overall
Mid-Gnd: Stainless Steel,
Mate Ground: Stainless Steel,
Top Shell: Stainless Steel, Ni Plated 50u" Min Over all
Shell: Stainless Steel, Ni Plated 50u" Min
Gasket Ring: Silicone, Color: Blank
- Current Rating: 5A Max.
- Voltage Rating: 20V.
- Working Temperature: -40°C ~ +105°C.
- Water protection IPx8 (Water slot with 1.5M/30Minutes)
- Harmful material should be compliant to doc. "EI-0005" standards.

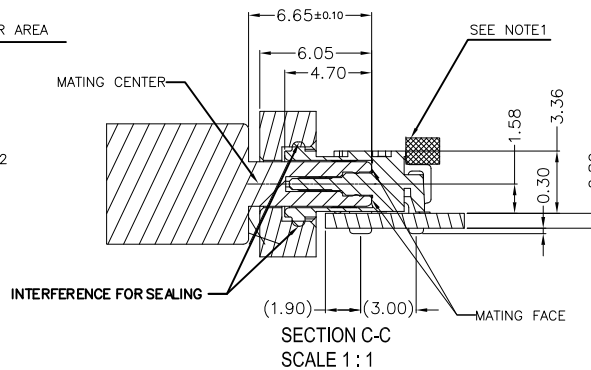
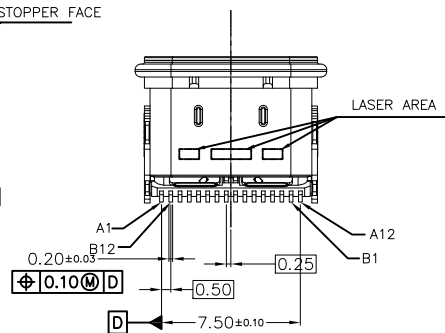
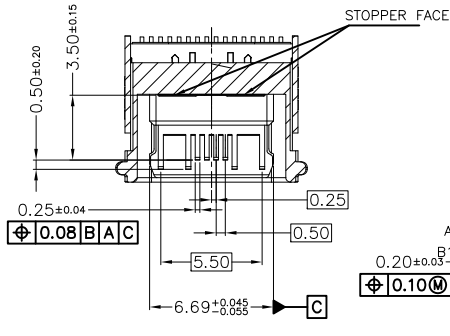

TOLERANCE TABLE	
X ± 0.30	X ° ± 3°
.X ± 0.25	.X ° ± 2°
.XX ± 0.20	

Singatron Enterprise Co., Ltd.				
TITLE	USB TYPE-C WATERPROOF CONNECTOR			
DWN	何曉明	PART NO.	2UB-MFABC016KJ00	
CHKD	2022/07/16	SCALE	1:1	UNIT: mm
APVD	鄧清華	SIZE	A3	SHEET: 1 OF 4 REV: 1
CUSTOMER COPY				

1 2 3 4 5 6 7 8

1 2 3 4 5 6 7 8

NOTE :

1. IN ORDER TO PREVENT DAMAGE, THE CONNECTOR SHOULD BE PROTECTED WITH CASE.
2. THERE IS A POSSIBILITY OF BURR OR PELLICLE OCCUR AT LIM PART. BUT IT HAS NO IMPACT FOR PRODCUTION, ASSEMBLY AND WATERPROOF ABILITY.

RELATIVE POSITON FOR APPLICATION

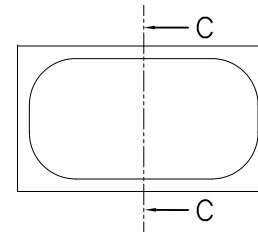
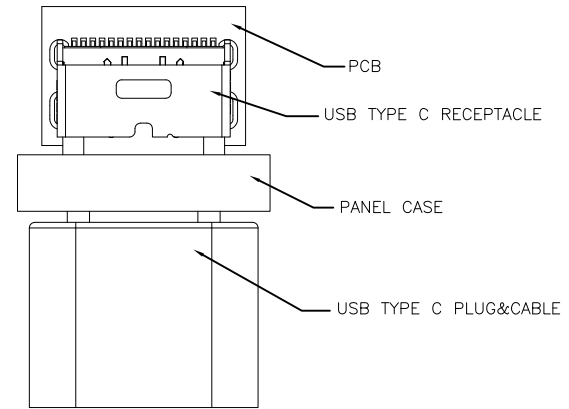

PART NO. :

2UB-MFABC016 K J 00

Number of contacts
16:16PIN

K:Reel

Plating Code:
Contact area:30u" Gold Plating.
G/F On Solder Area

Singatron Enterprise Co., Ltd.

TOLERANCE TABLE		TITLE	USB TYPE-C WATERPROOF CONNECTOR		
X. ± 0.30	X.° ± 3°	DWN	何曉明	PART NO. 2UB-MFABC016KJ00	
.X ± 0.25	.X° ± 2°	CHKD	2022/07/16	SCALE 1:1	UNIT: mm
.XX ± 0.20		APVD	鄧清華	SIZE: A3	SHEET:2 OF 4
REV: 1					
CUSTOMER COPY					

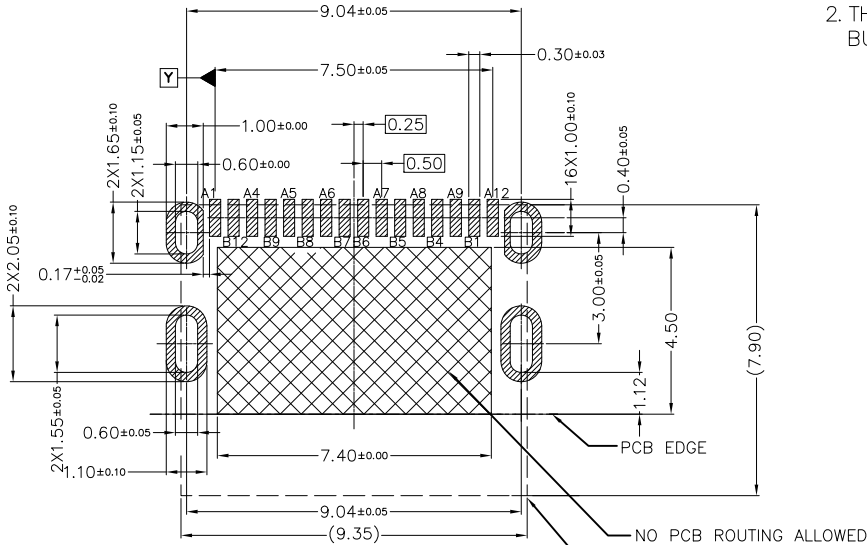

RECOMMENDED PCB LAYOUT
TOLERANCE: ±0.05

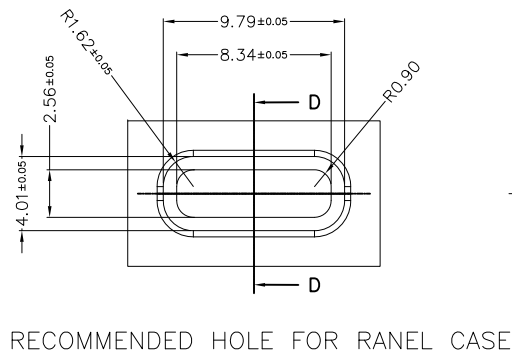

RECOMMENDED HOLE FOR PANEL CASE

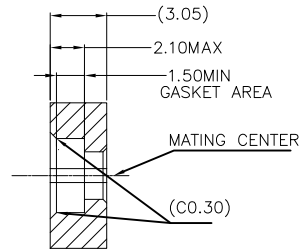

SECTION D-D
SCALE 1:1

1 2 3 4 5 6 7 8

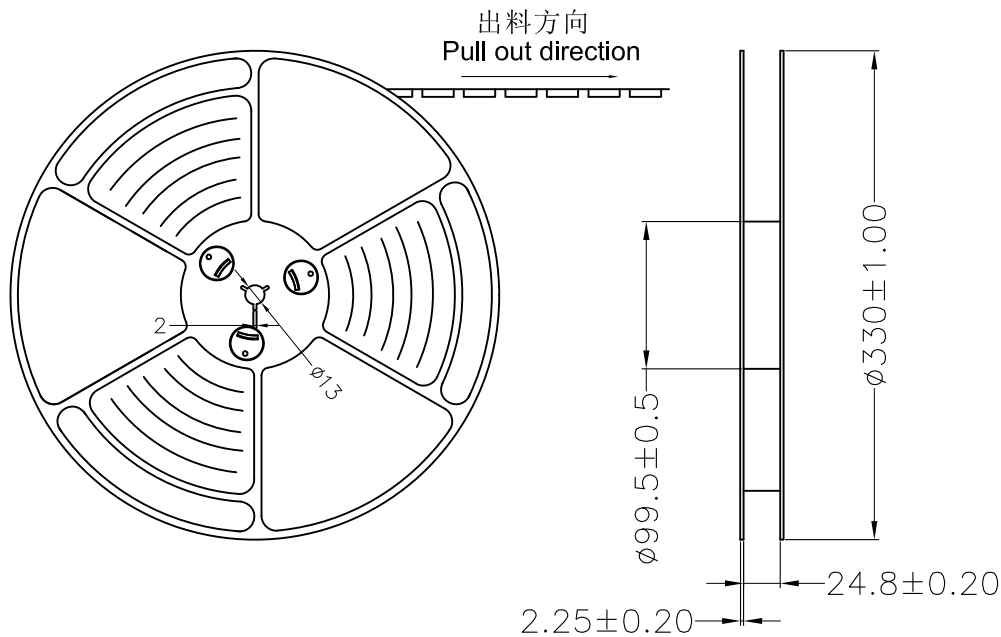

备注 (NOTES):

- 带子引导长度
Lead tape length

转绕方向
Pull out direction

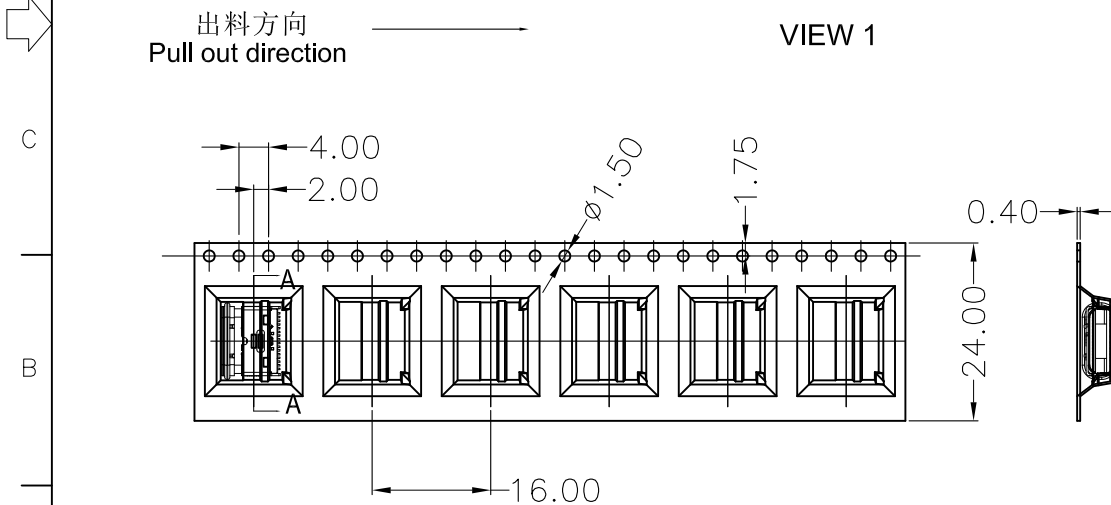
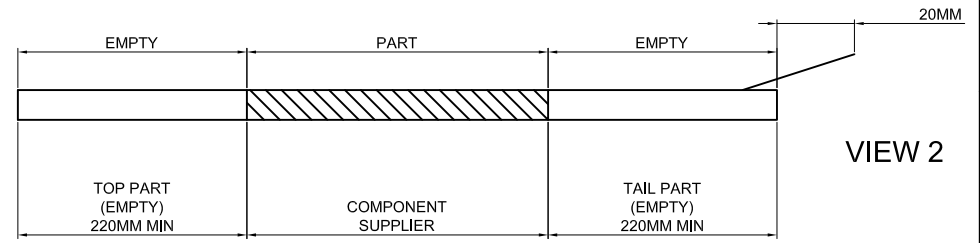

- 上带剥拉力为: 0.2~1.3N(20gf~130gf)

Peeling off force of top tape :0.2~1.3N(20gf~130gf)

出货运输过程中一定注意: 卷带在运输过程中不能散开

This requirement should be applied at shipment:

The reel tape can not be separated during transportation.

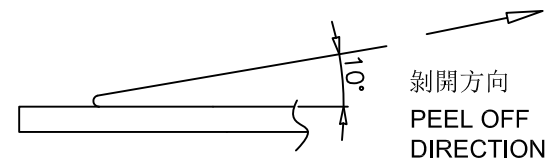

VIEW 3

Singatron Enterprise Co., Ltd.

TOLERANCE TABLE		TITLE			
X. ± 0.30	X.° ± 3°	USB TYPE-C WATERPROOF CONNECTOR			
.X ± 0.25	.X° ± 2°	DWN	何晓明	PART NO. 2UB-MFABC016KJ00	
.XX ± 0.20		CHKD	2022/07/16	SCALE 1:1	UNIT: mm
		APVD	鄧清華	SIZE: A3	SHEET: 3 OF 4
				REV: 1	
CUSTOMER COPY					

1 2 3 4 5 6 7 8

标签黏贴处(朝卷装包材的小定位孔一侧)
Location of label sticking (label at small positioning hole of the carrier tape side)

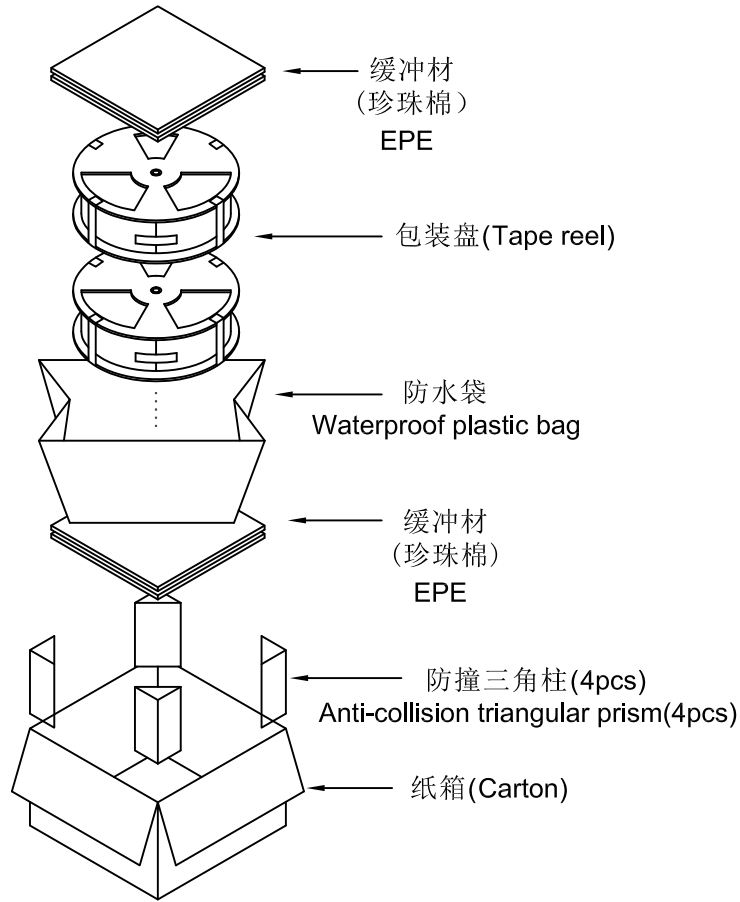

VIEW 4

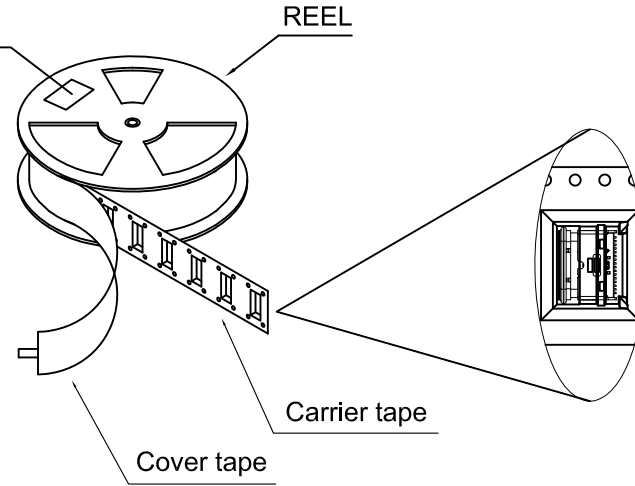

VIEW 5

备注 (NOTES):

- 每卷包装数量及每箱装箱数量如下表格。
Packing Q'ty of each reel & carton as below table shown.
- 上胶带覆盖下包装带用自粘包装。
Use cover tape to cover and seal up.
- 每个纸箱放2个珍珠棉。
Every carton use 2pcs EPE.
- 将装满产品的卷盘放入纸箱并以胶带封口。
Put reels in the carton and use adhesive tape to seal up.

A

产品料号 (Product No.)	包装数量(Packing Quantity)		
	PCS/REEL	REELS/CARTON	PCS/CARTON
2UB-MFABC016KJ00	700	7	4900

TOLERANCE TABLE	
X. ± 0.30	X.° ± 3°
.X ± 0.25	.X° ± 2°
.XX ± 0.20	

Singatron Enterprise Co., Ltd.

TITLE	USB TYPE-C WATERPROOF CONNECTOR		
DWN 何晓明	PART NO.	2UB-MFABC016KJ00	
CHKD 2022/07/16	SCALE	1:1	UNIT: mm
APVD 鄧清華	SIZE:	A3	SHEET: 4 OF 4
	REV:	1	

CUSTOMER COPY

1 2 3 4 5 6 7 8