

1 2 3 4 5 6 7 8

F

E

D

C

B

A

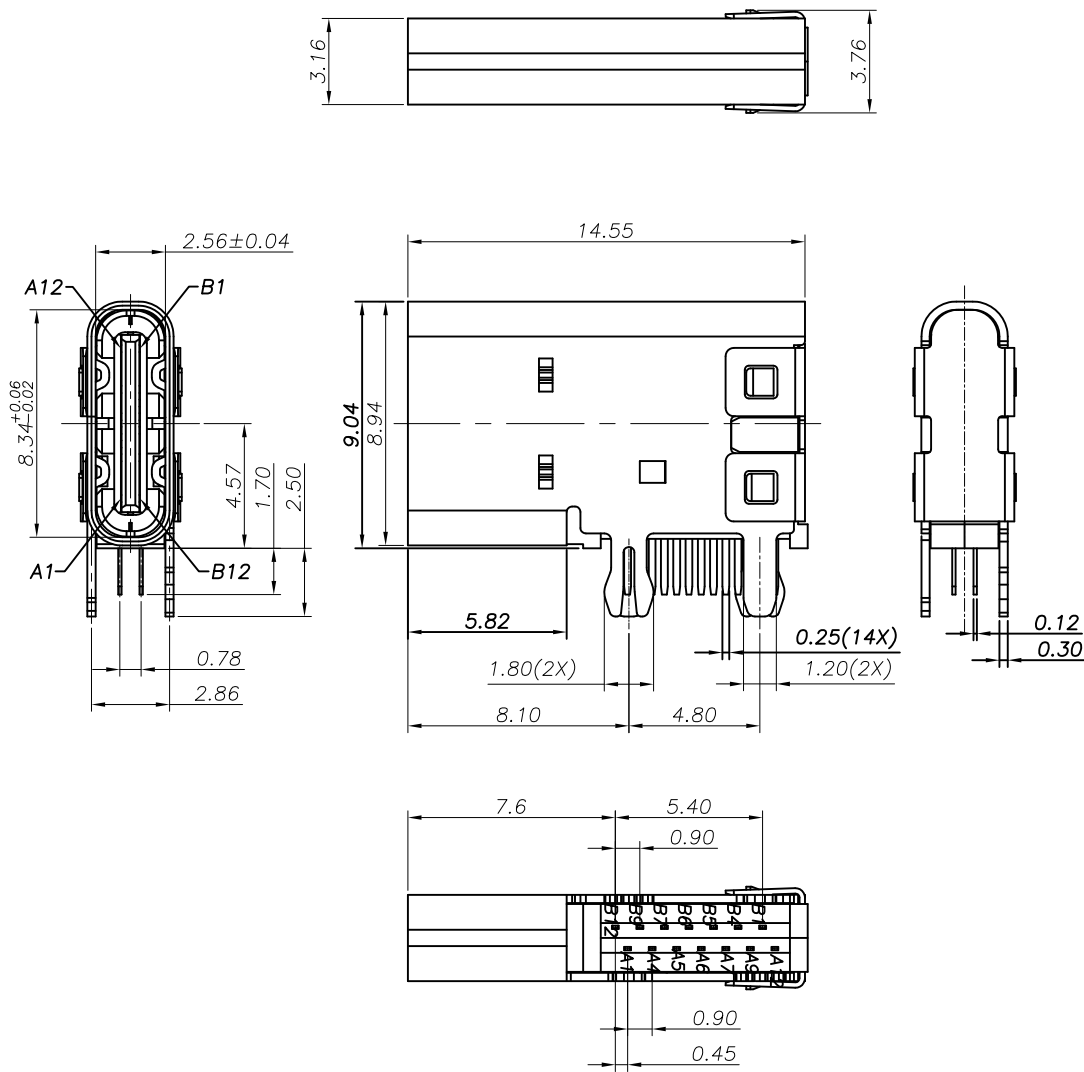

NOTE:

- 1.MATERIAL SPECIFICATION:
 - 1.HOUSING:LCP,UL94 V-0.
 - 2.TERMINAL: COPPER ALLOY(C1814)
 - 3.MID PLATE: STAINLESS STEEL(SUS301)
 - 4.FRONT SHELL: STAINLESS STEEL(SUS304)
 - 5.COVER: STAINLESS STEEL(SUS304)
- 2.PLATING SPECIFICATION:
 - 2-1.TERMINAL:
 - Ni 50u" MIN. UNDER PLATED OVER ALL.
 - Au PLATED ON THE FUNCTIONAL AREA OF CONTACT.
 - (GOLD PLATING THICKNESS FOLLOW THE P/N)
 - PLATING SPECIFICATIONS OF THE SOLDER AREA FOLLOW THE P/N
 - 2-2.FRONT SHELL:
 - Ni 30u" MIN. UNDER PLATED OVER ALL.
 - 2-3.MID PLATE&COVER:
 - CLEAR ONLY
- 3.MECHANICAL PERFORMANCE,
 - 3-1.INSERTION FORCE: 0.5~2.0kgf.
 - 3-2.REMOVAL FORCE: 0.8kgf~2.0kgf.
 - 3-3.DURABILITY: 10000 CYCLES.
- 4.ELECTRICAL PERFORMANCE,
 - 4-1. VOLTAGE RATING:5 V DC/AC (RMS. max)
CURRENT RATING:5 AMPS. FOR TOTAL VBUS/GND PINS;
1.25AMPS FOR CC PIN,0.25 AMPS. FOR ALL OTHER CONTACT.
 - 4-2. LLCR:
 - VBUS & GND PINS AND OTHER PINS: 40mΩ/PIN MAX.
 - SHIELD: 50mΩ/MAX.
 - LLCR MAX. CHANGE OF ALL PINS: 10mΩ.
 - 4-3.INSULATION RESISTANCE: 100MΩ MIN
 - 4-4.DIELECTRIC WITHSTAND VOLTAGE,AC 100V FOR 1 MINUTE.
5. ENVIRONMENTAL PERFORMANCE:
 - OPERATING TEMPERATURE: -25°C~+85°C.
- 6.IR REFLOW:
 - THE PEAK TEMPERATURE ON THE BOARD SHALL BE MAINTAINED FOR 10 SECONDS AT 260°C.

ITEM	P/N	HOUSING COLOR	FUNCTIONAL AREA	SOLDER AREA
1	2UB012A1H103-OHT	BLACK	Au:3u"	Au:G/F

TOLERANCE		Singatron Enterprise Co., Ltd.			
X.X ±0.30	X.' ±10°	TITLE	USB CF 14PIN FLAG TYPE		
.XX ±0.20	.X' ± 8°	DWN	P.JF	PART NO. 2UB012A1H103-OHT	
.XXX ±0.10	.XX' ± 5°	CHKD	2020.12.08	SCALE 1:1	UNIT: mm
UNITS	mm	APVD		SIZE: A3	SHEET:1 OF 3
MATERILA		REV: D			
FINISH		CUSTOMER COPY			

1 2 3 4 5 6 7 8

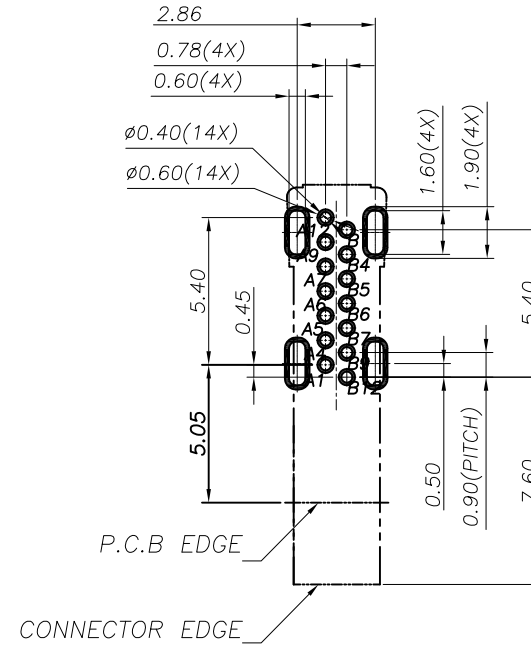
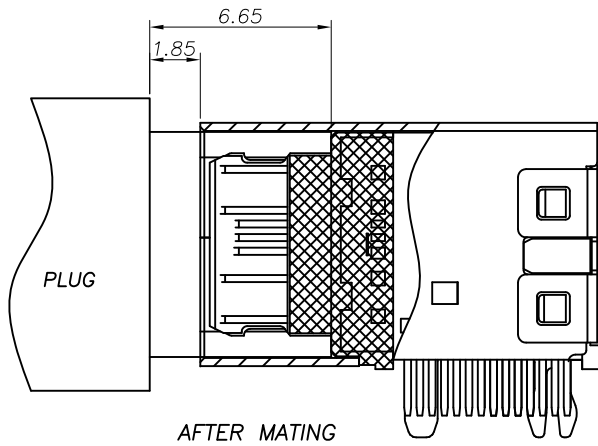

RECOMMENDED PCB LAYOUT(TOP VIEW)
THICKNESS 1.6±0.10MM;DEFAULT TOLERANCE:±0.05

USB TYPE-C PIN ASSIGNMENTS

PIN NUMBER	SIGNAL NAME	PIN NUMBER	SIGNAL NAME
A1	GND	B12	GND
A4	VBUS	B9	VBUS
A5	CC1		
A6	Dp1	B7	Dn2
A7	Dn1	B6	Dp2
		B5	CC2
A9	VBUS	B4	VBUS
A12	GND	B1	GND

TOLERANCE		Singatron Enterprise Co., Ltd.			
X.X ±0.30	X.' ±10°	TITLE	USB CF 14PIN FLAG TYPE		
.XX ±0.20	.X' ± 8°	DWN	P.JF	PART NO. 2UB012A1H103-0HT	
.XXX ±0.10	.XX' ± 5°	CHKD	2020.12.08	SCALE 1:1	UNIT: mm
UNITS	mm	APVD		SIZE: A3	SHEET:2 OF 3
MATERILA		REV: D			
FINISH		CUSTOMER COPY			

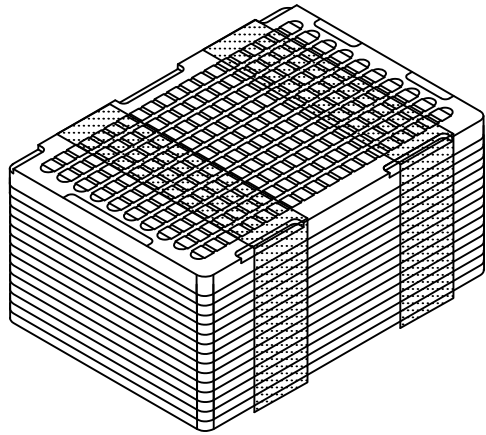

EACH BUNDLE WITH
40 LAYERS

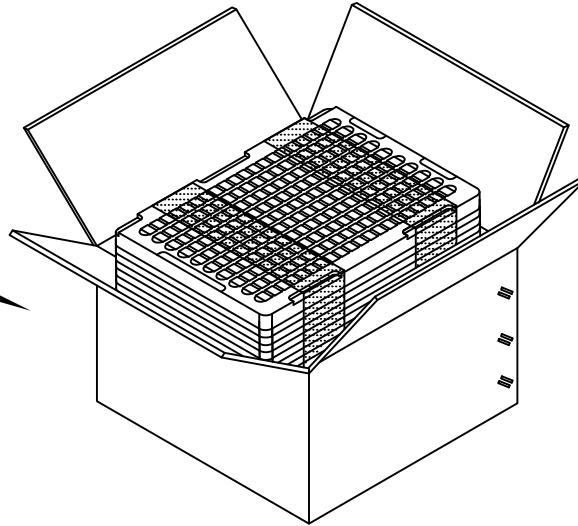

EACH CARTON WITH
6800 PCS PRODUCTS

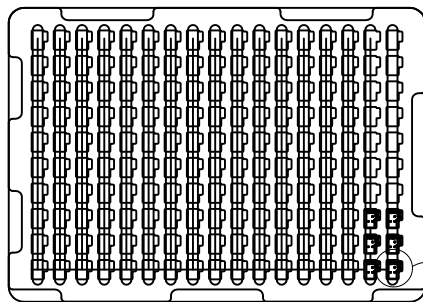
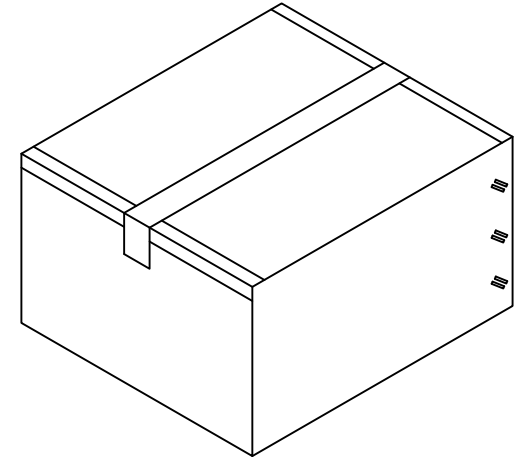

170 PCS/TRAY

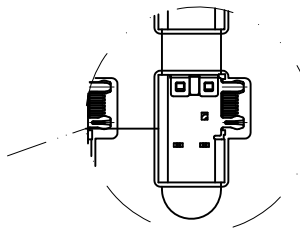

	TRAY	CARTON
CONNECTOR (PCS)	170	6800

TOLERANCE		Singatron Enterprise Co., Ltd.			
X.X ±0.30	X.' ±10°	TITLE	USB CF 14PIN FLAG TYPE		
.XX ±0.20	.X' ± 8°	DWN	PJF	PART NO. 2UB012A1H103-0HT	
.XXX ±0.10	.XX' ± 5°	CHKD	2020.12.08	SCALE 1:1	UNIT: mm
UNITS	mm	APVD		SIZE: A3	SHEET: 3 OF 3
MATERILA		REV: D			
FINISH		CUSTOMER COPY			