

RECOMMENDED PCBA LAYOUT
(TOLERANCE ± 0.05)

NOTES:

- 1. ELECTRONIC:
 - CONTACT CURRENT RATING: 1.5A
 - CONTACT RESISTANCE: 30mohm Max
 - INSULATION RESISTANCE: 1000 Megohms Min
 - WITHSTAND VOLTAGE: AC100V, 1Min.
- 2. MECHANICAL:
 - MATING FORCE: 3.57KG Max
 - UNMATED FORCE: 0.8KG Min
 - DURABILITY: 1500 CYCLES
- 3. ENVIRONMENT CHARACTERISTICS:
 - OPERATING TEMPERATURE: -40° C TO $+85^{\circ}$ C

PIN NUMBER	SIGNAL NAME
1	VBUS
2	D-
3	D+
4	GND
5	StdA_SSRX-
6	StdA_SSRX+
7	GND_DRAIN
8	StdA_SSTX-
9	StdA_SSTX+
Shell	Shield

4.MATERIAL LIST:

No.	PART NAME	QTY	MATERIAL	REMARK
3	SHELL	1	COPPER ALLOY/SUS/SPCC	NI PLATED
2	CONTACT	9	COPPER ALLOY	AU /TIN PLATED
1	HOUSING	1	THERMOPLASTIC(LCP)	(UL 94V-0) BLUE

UNLESS OTHERWISE SPECIFIED TOLERANCES				Singatron Enterprise Co., Ltd.			
DECIMALS:		ANGLES:		TITLE	USB3.2 Gen2 AF SMT 沉板		
DIM	TOL	DIM	TOL	DWN	Tony	PART NO. 2UB09-1589-000H	
x.	± 0.50	x.	$\pm 2^{\circ}$	CHKD	2020.3.15	SCALE 1:1	UNIT: mm
x.x	± 0.30	x.x	$\pm 1^{\circ}$	APVD	Andy	SIZE: A3	SHEET: 1 OF 2
x.xx	± 0.20	x.xx		REV: A1			
x.xxx	± 0.10	x.xxx		CUSTOMER COPY			

1 2 3 4 5 6 7 8

F F

E E

D D

C C

B B

A A

1 2 3 4 5 6 7 8

1 2 3 4 5 6 7 8

LABEL DESCRIPTION

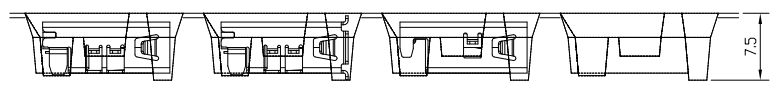
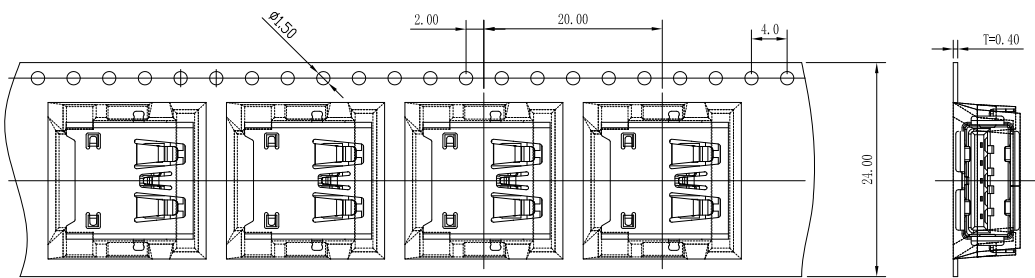
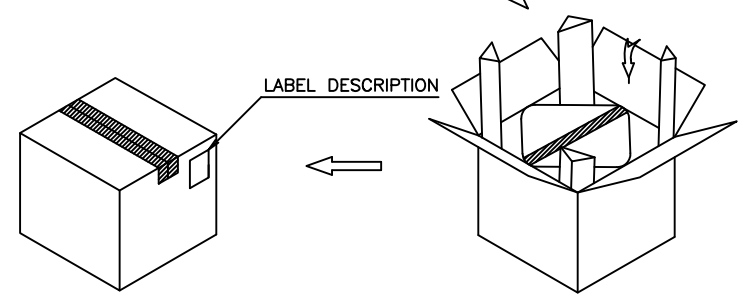
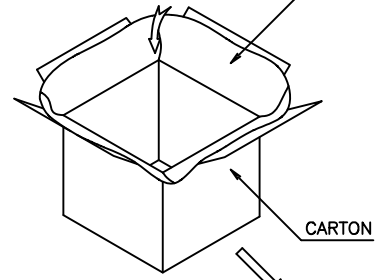
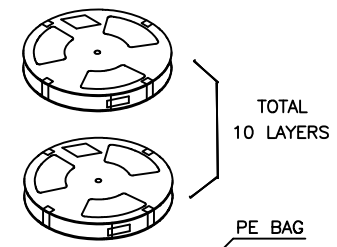
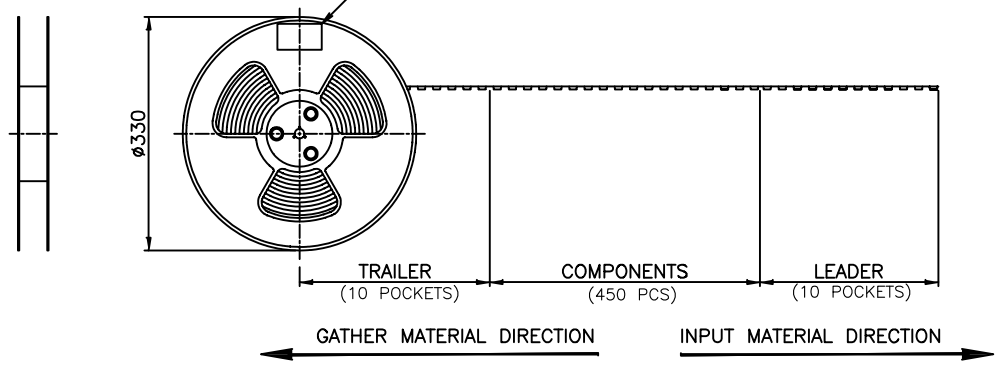

	REEL/TRAY	CARTON
CONNECTOR (PCS)	450	4500

UNLESS OTHERWISE SPECIFIED TOLERANCES

DECIMALS:		ANGLES:	
DIM	TOL	DIM	TOL
X.	±0.50	X.	±2°
X.X	±0.30	X.X	±1°
X.XX	±0.20	X.XX	
X.XXX	±0.10	X.XXX	

Singatron Enterprise Co., Ltd.					
TITLE	USB3.2 Gen2 AF SMT 沉板				
DWN	Tony	PART NO. 2UB09-1589-000H			
CHKD	2020.3.15	SCALE 1:1	UNIT: mm	④ ↺	
APVD	Andy	SIZE: A3	SHEET: 2 OF 2	REV: A1	
CUSTOMER COPY					